

Owner's Manual

Stationary Emergency Generator

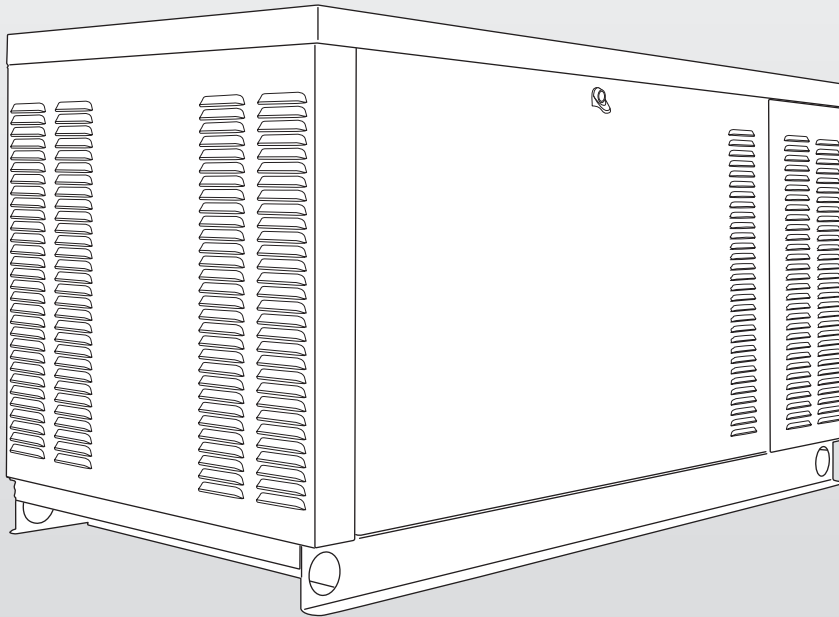

▲ CAUTION!

▲ NOT INTENDED FOR USE IN CRITICAL LIFE SUPPORT APPLICATIONS. ONLY QUALIFIED ELECTRICIANS OR CONTRACTORS SHOULD ATTEMPT INSTALLATION! DEADLY EXHAUST FUMES! OUTDOOR INSTALLATION ONLY!

1.6L
25/30kW Models
EPA Certified

This manual should remain with the unit.

Table of Contents

SECTION	PAGE		
INTRODUCTION	1-1		
Read this Manual Thoroughly	1-1		
Operation and Maintenance	1-1		
How to Obtain Service	1-1		
SAFETY RULES	1-2		
GENERAL INFORMATION	2-1		
Identification Record	2-1		
Data Label	2-1		
EQUIPMENT DESCRIPTION	3-1		
Equipment Description	3-1		
Engine Oil Recommendations	3-1		
Coolant Recommendations	3-1		
ENGINE PROTECTIVE DEVICES	4-1		
Engine Protective Devices	4-1		
High Coolant Temperature Sender	4-1		
Low Coolant Level Sensor	4-1		
Low Oil Pressure Switch	4-1		
Overcrank Shutdown	4-1		
Overspeed Shutdown	4-1		
RPM Sensor Loss Shutdown	4-1		
DC Fuses	4-1		
FUEL SYSTEM	5-1		
Fuel Requirements	5-1		
Natural Gas Fuel System	5-1		
Propane Vapor Withdrawal Fuel System	5-1		
LP Liquid Fuel System	5-1		
SPECIFICATIONS	6-1		
Stationary Emergency Generator	6-1		
Engine	6-1		
Cooling System	6-1		
Fuel System	6-1		
Electrical System	6-1		
Weather and Maintenance Kits	6-2		
Reconfiguring the Fuel System	6-2		
Fuel System	6-2		
Control Panel	6-2		
GENERAL INFORMATION	7-1		
Alternator AC Lead Connections	7-1		
Four-lead, Single-phase Stator	7-1		
Alternator Power Winding Connections	7-1		
3-phase Alternators ("Y" Configuration)	7-1		
3-phase Alternators ("Delta" Configuration)	7-2		
CONTROL PANEL	8-1		
Control Panel Interface	8-1		
Using the Auto/Off/Manual Switch	8-1		
Activate the Generator	8-1		
Display Interface Menus	8-1		
Activation Chart	8-2		
Setting the Exercise Timer	8-3		
Low Speed Exercise	8-3		
User Adjustable Settings	8-3		
Fuel Conversion	8-3		
Operation	8-3		
Automatic Transfer Operation	8-3		
Sequence of Automatic Operation	8-4		
Crank Cycles and Overcrank Shutdown	8-4		
Auto Start	8-4		
Manual Start	8-4		
		Alarm and Warning Messages	8-4
		Low Oil Pressure Shutdown Alarm	8-4
		High Coolant Temperature Shutdown Alarm	8-4
		Overcrank Shutdown Alarm	8-4
		Overspeed Shutdown Alarm	8-4
		RPM Sensor Failure Shutdown Alarm	8-4
		Under-frequency Shutdown Alarm	8-5
		Low Battery Alarm	8-5
		Low Battery Warning	8-5
		Low Coolant Level Alarm	8-5
		Missing Cam Pulse Alarm	8-5
		Missing Crank Pulse Alarm	8-5
		Low Fuel Pressure Warning	8-5
		Governor Sensor Fault Alarm	8-5
		Wiring Error Alarm	8-5
		Undervoltage Alarm	8-5
		Overvoltage Alarm	8-6
		Internal Failure Shutdown Alarm	8-6
		Canbus Alarm	8-6
		Ignition Alarm	8-6
		Maintenance Warning	8-6
		Alarm Cancel	8-6
		Common Alarm Relay	8-6
		Maintenance Alerts	8-6
		Menu System	8-7
		OPERATION	9-1
		Stationary Emergency Generator Control and Operation	9-1
		Operating Unit with Manual Transfer Switch	9-1
		Engine Start-up and Transfer	9-1
		Retransfer and Shutdown	9-1
		Operating Unit with Automatic Transfer Switch	9-1
		MAINTENANCE	10-1
		General Maintenance	10-1
		Check Engine Oil	10-1
		Changing Engine Oil	10-1
		Cooling Intake/Outlet	10-1
		Inspect Cooling System	10-1
		Engine Coolant	10-2
		Coolant Change	10-2
		Overload Protection for Engine DC Electrical System	10-2
		Exercise System	10-2
		Perform Visual Inspection	10-2
		Inspect Exhaust System	10-2
		Check Fan Belt	10-2
		Inspect Engine Governor	10-2
		Changing the Engine Air Filter	10-2
		Spark Plugs	10-3
		Battery Maintenance	10-3
		Battery Replacement	10-3
		Battery Fluid	10-3
		Cleaning the Stationary Emergency Generator	10-3
		SERVICE SCHEDULE	11-1
		TROUBLESHOOTING	12-1
		Troubleshooting Guide	12-1
		EMISSIONS WARRANTY	13-1
		NOTES	
		EXPLODED VIEWS & PARTS LISTS	
		WIRING DIAGRAMS & SCHEMATICS	

Safety Instructions

 **SAVE THESE INSTRUCTIONS** – The manufacturer suggests that these rules for safe operation be copied and posted in potential hazard areas. Safety should be stressed to all operators, potential operators, and service and repair technicians for this equipment.

INTRODUCTION

Thank you for purchasing this model of the stationary emergency generator product line.

Every effort was expended to make sure that the information and instructions in this manual were both accurate and current at the time the manual was written. However, the manufacturer reserves the right to change, alter or otherwise improve this product(s) at any time without prior notice.

READ THIS MANUAL THOROUGHLY

If any portion of this manual is not understood, contact the nearest Service Dealer for starting, operating and servicing procedures.

Throughout this publication, and on tags and decals affixed to the generator, DANGER, WARNING, CAUTION and NOTE blocks are used to alert personnel to special instructions about a particular service or operation that may be hazardous if performed incorrectly or carelessly. Observe them carefully. Their definitions are as follows:

DANGER!

INDICATES A HAZARDOUS SITUATION OR ACTION WHICH, IF NOT AVOIDED, WILL RESULT IN DEATH OR SERIOUS INJURY.

WARNING!

Indicates a hazardous situation or action which, if not avoided, could result in death or serious injury.

CAUTION!

Indicates a hazardous situation or action which, if not avoided, could result in minor or moderate injury.

NOTE:

Notes contain additional information important to a procedure and will be found within the regular text body of this manual.

These safety warnings cannot eliminate the hazards that they indicate. Common sense and strict compliance with the special instructions while performing the service are essential to preventing accidents.

Four commonly used safety symbols accompany the DANGER, WARNING and CAUTION blocks. The type of information each indicates is as follows:

 **This symbol points out important safety information that, if not followed, could endanger personal safety and/or property of others.**

 **This symbol points out potential explosion hazard.**

 **This symbol points out potential fire hazard.**

 **This symbol points out potential electrical shock hazard.**

The operator is responsible for proper and safe use of the equipment. The manufacturer strongly recommends that the operator read this Owner's Manual and thoroughly understand all instructions before using this equipment. The manufacturer also strongly recommends instructing other users to properly start and operate the unit. This prepares them if they need to operate the equipment in an emergency.

For safety reasons, the manufacturer recommends that this equipment be installed, serviced and repaired by a Service Dealer or other competent, qualified electrician or installation technician who is familiar with applicable codes, standards and regulations. The operator also must comply with all such codes, standards and regulations.

OPERATION AND MAINTENANCE

It is the operator's responsibility to perform all safety checks, to make sure that all maintenance for safe operation is performed promptly, and to have the equipment checked periodically by a Service Dealer. Normal maintenance service and replacement of parts are the responsibility of the owner/operator and, as such, are not considered defects in materials or workmanship within the terms of the warranty. Individual operating habits and usage contribute to the need for maintenance service.

Proper maintenance and care of the generator ensure a minimum number of problems and keep operating expenses at a minimum. See a Service Dealer for service aids and accessories.

Operating instructions presented in this manual assume that the generator electric system has been installed by a Service Dealer or other competent, qualified contractor. Installation of this equipment is not a "do-it-yourself" project.

HOW TO OBTAIN SERVICE

When the generator requires servicing or repairs, simply contact a Service Dealer for assistance. Service technicians are factory-trained and are capable of handling all service needs.

When contacting a dealer about parts and service, always supply the complete Model Number, Serial Number and Type Code (where applicable) from the DATA LABEL that is affixed to the unit.

Safety Instructions

SAFETY RULES

Study these SAFETY RULES carefully before installing, operating or servicing this equipment. Become familiar with this Owner's Manual and with the unit. The generator can operate safely, efficiently and reliably only if it is properly installed, operated and maintained. Many accidents are caused by failing to follow simple and fundamental rules or precautions.

The manufacturer cannot anticipate every possible circumstance that might involve a hazard. The warnings in this manual, and on tags and decals affixed to the unit are, therefore, not all inclusive. If a procedure, work method or operating technique is used that the manufacturer does not specifically recommend, ensure that it is safe for others. Also make sure the procedure, work method or operating technique utilized does not render the generator unsafe.

⚠ DANGER!

⚠ Despite the safe design of this generator, operating this equipment imprudently, neglecting its maintenance or being careless can cause possible injury or death. Permit only responsible and capable persons to install, operate or maintain this equipment.

⚠ Potentially lethal voltages are generated by these machines. Ensure all steps are taken to render the machine safe before attempting to work on the generator.

⚠ Parts of the generator are rotating and/or hot during operation. Exercise care near running generators.

GENERAL HAZARDS

- For safety reasons, the manufacturer recommends that this equipment be installed, serviced and repaired by a Service Dealer or other competent, qualified electrician or installation technician who is familiar with applicable codes, standards and regulations. The operator also must comply with all such codes, standards and regulations.
- Installation, operation, servicing and repair of this (and related) equipment must always comply with applicable codes, standards, laws and regulations. Adhere strictly to local, state and national electrical and building codes. Comply with regulations the Occupational Safety and Health Administration (OSHA) has established. Also, ensure that the generator is installed, operated and serviced in accordance with the manufacturer's instructions and recommendations. Following installation, do nothing that might render the unit unsafe or in noncompliance with the aforementioned codes, standards, laws and regulations.

- The engine exhaust fumes contain carbon monoxide gas, which can be DEADLY. This dangerous gas, if breathed in sufficient concentrations, can cause unconsciousness or even death. For that reason, adequate ventilation must be provided. This should be considered prior to installing the generator. The unit should be positioned to direct exhaust gasses safely away from any building where people, animals, etc., will not be harmed. Any exhaust stacks that ship loose with the unit must be installed properly per the manufacturer's instruction, and in strict compliance with applicable codes and standards.
- Keep hands, feet, clothing, etc., away from drive belts, fans, and other moving or hot parts. Never remove any drive belt or fan guard while the unit is operating.
- Adequate, unobstructed flow of cooling and ventilating air is critical in any room or building housing the generator to prevent buildup of explosive gases and to ensure correct generator operation. Do not alter the installation or permit even partial blockage of ventilation provisions, as this can seriously affect safe operation of the generator.
- Keep the area around the generator clean and uncluttered. Remove any materials that could become hazardous.
- When working on this equipment, remain alert at all times. Never work on the equipment when physically or mentally fatigued.
- Inspect the generator regularly, and promptly repair or replace all worn, damaged or defective parts using only factory-approved parts.
- Before performing any maintenance on the generator, disconnect its battery cables to prevent accidental start-up. Disconnect the cable from the battery post indicated by a NEGATIVE, NEG or (-) first. Reconnect that cable last.
- Never use the generator or any of its parts as a step. Stepping on the unit can stress and break parts, and may result in dangerous operating conditions from leaking exhaust gases, fuel leakage, oil leakage, etc.

ELECTRICAL HAZARDS

- All stationary emergency generators covered by this manual produce dangerous electrical voltages and can cause fatal electrical shock. Utility power delivers extremely high and dangerous voltages to the transfer switch as well as the generator. Avoid contact with bare wires, terminals, connections, etc., on the generator as well as the transfer switch, if applicable. Ensure all appropriate covers, guards and barriers are in place before operating the generator. If work must be done around an operating unit, stand on an insulated, dry surface to reduce shock hazard.
- Do not handle any kind of electrical device while standing in water, while barefoot, or while hands or feet are wet. DANGEROUS ELECTRICAL SHOCK MAY RESULT.

Safety Instructions

- If personnel must stand on metal or concrete while installing, operating, servicing, adjusting or repairing this equipment, place insulative mats over a dry wooden platform. Work on the equipment only while standing on such insulative mats.
- The National Electrical Code (NEC) requires the frame and external electrically conductive parts of the generator to be connected to an approved earth ground. This grounding will help prevent dangerous electrical shock that might be caused by a ground fault condition in the generator or by static electricity. Never disconnect the ground wire.
- Wire gauge sizes of electrical wiring, cables and cord sets must be adequate to handle the maximum electrical current (ampacity) to which they will be subjected.
- Before installing or servicing this (and related) equipment, make sure that all power voltage supplies are positively turned off at their source. Failure to do so will result in hazardous and possibly fatal electrical shock.
- Connecting this unit to an electrical system normally supplied by an electric utility shall be by means of a transfer switch so as to isolate the generator electric system from the electric utility distribution system when the generator is operating. Failure to isolate the two electric system power sources from each other by such means will result in damage to the generator and may also result in injury or death to utility power workers due to backfeed of electrical energy.
- Stationary emergency generators installed with an automatic transfer switch will crank and start automatically when normal (utility) source voltage is removed or is below an acceptable preset level. To prevent such automatic start-up and possible injury to personnel, disable the generator's automatic start circuit (battery cables, etc.) before working on or around the unit. Then, place a "Do Not Operate" tag on the generator control panel and on the transfer switch.
- In case of accident caused by electric shock, immediately shut down the source of electrical power. If this is not possible, attempt to free the victim from the live conductor. AVOID DIRECT CONTACT WITH THE VICTIM. Use a nonconducting implement, such as a dry rope or board, to free the victim from the live conductor. If the victim is unconscious, apply first aid and get immediate medical help.
- Never wear jewelry when working on this equipment. Jewelry can conduct electricity resulting in electric shock, or may get caught in moving components causing injury.

FIRE HAZARDS

- Keep a fire extinguisher near the generator at all times. Do NOT use any carbon tetra-chloride type extinguisher. Its fumes are toxic, and the liquid can deteriorate wiring insulation. Keep the extinguisher properly charged and be familiar with its use. If there are any questions pertaining to fire extinguishers, consult the local fire department.

EXPLOSION HAZARDS

- Properly ventilate any room or building housing the generator to prevent build-up of explosive gas.
- Do not smoke around the generator. Wipe up any fuel or oil spills immediately. Ensure that no combustible materials are left in the generator compartment, or on or near the generator, as FIRE or EXPLOSION may result. Keep the area surrounding the generator clean and free from debris.
- These generators may operate using one of several types of fuels. All fuel types are potentially FLAMMABLE and/or EXPLOSIVE and should be handled with care. Comply with all laws regulating the storage and handling of fuels. Inspect the unit's fuel system frequently and correct any leaks immediately. Fuel supply lines must be properly installed, purged and leak tested according to applicable fuel-gas codes before placing this equipment into service.
- Diesel fuels are highly FLAMMABLE. Gaseous fluids such as natural gas and liquid propane (LP) gas are extremely EXPLOSIVE. Natural gas is lighter than air, and LP gas is heavier than air; install leak detectors accordingly.

CALIFORNIA PROPOSITION 65 WARNING

Engine exhaust and some of its constituents are known to the State of California to cause cancer, birth defects and other reproductive harm.

CALIFORNIA PROPOSITION 65 WARNING

This product contains or emits chemicals known to the State of California to cause cancer, birth defects and other reproductive harm.

General Information

IDENTIFICATION RECORD

DATA LABEL

Every generator set has a DATA LABEL that contains important information pertinent to the generator. The data label, which can be found attached to the generator's lower connection box, lists the unit's serial number and its rated voltage, amps, wattage capacity, phase, frequency, rpm, power factor, production date, etc.

NOTE:

For actual information related to this particular model, please refer to the Manual Drawing Listing located at the end of this manual, or to the data label affixed to the unit.

Stationary Emergency Generator Model and Serial Number

This number is the key to numerous engineering and manufacturing details pertaining to your unit. Always supply this number when requesting service, ordering parts or seeking information.

Data Label

MODEL	<input type="text"/>	<input type="text"/>	
PROD DATE	<input type="text"/>	SERIAL <input type="text"/>	
KW <input type="text"/>	KVA <input type="text"/>	PHASE <input type="text"/>	HERTZ <input type="text"/>
VOLT <input type="text"/>	AMP <input type="text"/>	PWR FACT <input type="text"/>	ALT RPM <input type="text"/>
ENG RPM <input type="text"/>	TYPE CODE <input type="text"/>		
ALT SUBTRANS REACTANCE <input type="text"/>	ALT TRANS REACTANCE <input type="text"/>		
CLASS <input type="checkbox"/> ROTOR <input type="checkbox"/> STATOR WINDING INS AT 25°C AMB			
<input type="text"/>		<input type="text"/>	
MODEL NO (CAT/CUST NO)		SERIAL NO	
<input type="text"/>		<input type="text"/>	
<input type="text"/>		<input type="text"/>	

0G2110 REV C

EQUIPMENT DESCRIPTION

This equipment is a revolving field, alternating current Stationary Emergency Generator. It is powered by a gaseous fueled engine operating at 1800 rpm for 4-pole direct drive units, 3600 rpm for 2-pole direct drive units and 2300 - 3000 rpm for quiet drive gear units. See the Specifications section for exact numbers. The unit comes complete with a sound attenuated enclosure, internally mounted muffler, control console, mainline circuit breaker, battery charger, and protective alarms as explained in the following paragraph.

All AC connections, including the power leads from the alternator, 120 volt battery charger input and control connections to the transfer switch are available in the main connection box.

The Stationary Emergency Generator incorporates the following alternator features:

- Rotor and Stator insulation is Class F rated as defined by NEMA MG1-32.6, NEMA MG1-1.66. The generator is self ventilated and drip-proof constructed.
- The voltage waveform deviation, total harmonic content of the AC waveform and telephone influence factor have been evaluated and are acceptable according to NEMA MG1-32.

ENGINE OIL RECOMMENDATIONS

The unit has been filled with 5W-20 engine oil at the factory. Use a high-quality detergent oil classified "For Service SJ or SH." Detergent oils keep the engine cleaner and reduce carbon deposits. When changing the engine oil, be sure to use 5W-30 engine oil (synthetic oil is recommended).

⚠ CAUTION!

- ⚠ Any attempt to crank or start the engine before it has been properly serviced with the recommended oil may result in an engine failure.

NOTE:

For temperatures below 32° F, it is strongly recommended to use the optional Cold Weather Start Kit. The oil grade for temperatures below 32° F is 5W-30 synthetic oil.

COOLANT RECOMMENDATIONS

Use a mixture of half low silicate ethylene glycol base anti-freeze and deionized water. Cooling system capacity is listed in the specifications. Use only deionized water and only low silicate anti-freeze. If desired, add a high quality rust inhibitor to the recommended coolant mixture. When adding coolant, always add the recommended 50-50 mixture.

⚠ CAUTION!

- ⚠ Do not use any chromate base rust inhibitor with ethylene glycol base anti-freeze or chromium hydroxide ("green slime") forms and will cause overheating. Engines that have been operated with a chromate base rust inhibitor must be chemically cleaned before adding ethylene glycol base anti-freeze. Using any high silicate anti-freeze boosters or additives will also cause overheating. The manufacturer also recommends that any soluble oil inhibitor is NOT used for this equipment.

⚠ DANGER!

- ⚠ Do not remove the radiator pressure cap while the engine is hot or serious burns from boiling liquid or steam could result.
- ⚠ Ethylene glycol base antifreeze is poisonous. Do not use mouth to siphon coolant from the radiator, recovery bottle or any container. Wash hands thoroughly after handling. Never store used antifreeze in an open container because animals are attracted to the smell and taste of antifreeze even though it is poisonous to them.

Engine Protective Devices

ENGINE PROTECTIVE DEVICES

The Stationary Emergency Generator may be required to operate for long periods of time without an operator on hand to monitor such engine conditions as coolant temperature, oil pressure or rpm. For that reason, the engine has several devices designed to protect it against potentially damaging conditions by automatically shutting down the unit when the oil pressure is too low, the coolant temperature is too high, the coolant level is too low, or the engine is running too fast.

NOTE:

Engine protective switches and sensors are mentioned here for the reader's convenience. Also refer to the applicable control panel manual for additional automatic engine shutdown information.

HIGH COOLANT TEMPERATURE SENDER

An analog coolant temperature sender, located in the engine's cooling system will cause an engine shutdown if the temperature should exceed approximately 125° C (257° F). The generator will automatically restart once the temperature has returned to a safe operating level.

LOW COOLANT LEVEL SENSOR

To prevent overheating, the engine has a low coolant level sensor. If the level of engine coolant drops below the level of the low coolant level sensor, the engine automatically shuts down.

LOW OIL PRESSURE SWITCH

This switch has normally closed contacts that are held open by engine oil pressure during cranking and operating. Should oil pressure drop below the 8 psi range, switch contacts close, and the engine shuts down. The unit should not be restarted until oil is added, and the AUTO/OFF/MANUAL switch must be turned to OFF and then back to AUTO.

OVERCRANK SHUTDOWN

After a prespecified duration of cranking, this function ends the cranking if the engine has failed to start. The overcrank message will turn ON. Turn OFF the AUTO/OFF/MANUAL switch, then turn switch back to AUTO to reset the generator control board.

NOTE:

If the fault is not corrected, the overcrank feature will continue to activate.

Approximate Crank Cycle Times

- 15 seconds ON
- 7 seconds OFF
- 7 seconds ON
- 7 seconds OFF
- Repeat for 45 seconds
- Approximately 90 seconds total.

OVERSPEED SHUTDOWN

A speed circuit controls engine cranking, start-up, operation and shutdown. Engine speed signals are delivered to the circuit board whenever the unit is running. Should the engine overspeed above a safe, preset value, the circuit board initiates an automatic engine shutdown. Contact the nearest Authorized Dealer if this failure occurs.

RPM SENSOR LOSS SHUTDOWN

If the speed signal to the control panel is lost, engine shutdown will occur.

DC FUSES

A fuse (7.5 amp) is located on the control panel. It protects the panel components from damaging overload. **Always remove this fuse before commencing work on the generator.** The unit will not start or crank if the fuse is blown.

A fuse (25 amp) is located in the engine wire harness adjacent to the DC alternator. It is used to prevent circuit failure due to DC alternator failure. It will also protect the system in the event of a wiring short-circuit. If this fuse is blown, the generator will not operate. Replace these fuses with the same size, type, and rating.

FUEL SYSTEM

FUEL REQUIREMENTS

The Stationary Emergency Generator may be equipped with one of the following fuel systems:

- Natural gas fuel system
- Propane vapor (LPV) fuel system

Recommended fuels should have a Btu content of at least 1,000 Btu's per cubic foot for natural gas; or at least 2,520 Btu's per cubic foot for LP gas. Ask the fuel supplier for the Btu content of the fuel.

NOTE:

The fuel consumption requirements are identified in the Specifications section of the Owner's Manual. Refer to the Installation Manual if assistance is required for the sizing of the pipe diameter for the generator. Any piping used to connect the generator to the fuel supply should be of adequate size to achieve the 100% load fuel consumption requirements identified in the Specifications section regardless of actual load.

NOTE:

The recommended fuel pressure is identified in the Specifications section this manual.

NOTE:

It is the responsibility of the installer to make sure that only the correct recommended fuel is supplied to the generator fuel system. Thereafter, the owner/operator must make certain that only the proper fuel is supplied.

NATURAL GAS FUEL SYSTEM

Natural gas is supplied in its vapor state. In most cases, the gas distribution company provides piping from the main gas distribution line to the standby generator site. The following information applies to natural gas fuel systems.

- Gas pressure in a building is usually regulated by national, state and local codes.
- To reduce gas pressure to a safe level before the gas enters a building, a primary regulator is needed. The natural gas supplier may or may not supply such a regulator.
- It is the responsibility of the gas supplier to make sure sufficient gas pressure is available to operate the primary regulator.
- Gas pressure at the inlet to the fuel shutoff solenoid must never exceed approximately 14 inches water column (0.5 psi).

PROPANE VAPOR WITHDRAWAL FUEL SYSTEM

This type of system utilizes the vapors formed above the liquid fuel in the supply tank. Approximately 10 to 20 percent of the tank capacity is needed for fuel expansion from the liquid to the vapor state. The vapor withdrawal system is generally best suited for smaller engines that require less fuel. The installer should be aware of the following:

- When ambient temperatures are low and engine fuel consumption is high, the vapor withdrawal system may not function efficiently.
- Ambient temperatures around the supply tank must be high enough to sustain adequate vaporization, or the system will not deliver the needed fuel volume.
- In addition to the cooling effects of ambient air, the vaporization process itself provides an additional cooling effect.

Specifications

WEATHER AND MAINTENANCE KITS

To keep the generator running at its peak, the following kits are offered:

- Cold Weather Kit
 - ~ Recommended for climates with temperatures below 32° F.
- Extreme Cold Weather Kit
 - ~ Recommended Block Heater Kit for protection in temperatures below 32° F.
- Scheduled Maintenance Kit
 - ~ Kit includes the recommended parts to maintain the generator. Refer to the Service Schedule for regular maintenance intervals.

For additional information, or to order any of these kits, please contact an Authorized Service Dealer or Customer Service Representative.

RECONFIGURING THE FUEL SYSTEM

NOTE:

All models are configured to run on natural gas from the factory.

Before the generator can be operated using a LP fuel source, the fuel system and control panel (refer to the installation drawing for location) must be reconfigured. The steps to reconfigure the generator from a natural gas (NG) to a liquidified petroleum (LP) fuel source are as follows:

FUEL SYSTEM

1. Turn the main gas supply off and disconnect the battery.
2. Remove the carburetor fuel hose from the outlet port of the demand regulator (see Figure 6.1).
3. Disconnect the power wires from the fuel solenoid located on top of the regulator assembly by removing the screw on the front of the connector and pulling the connector forward, away from the solenoid body.
4. Loosen the spring clamp on the small fuel enrichment line and remove the hose from the hose barb.
5. Remove the black pipe assembly from the outlet port of the demand regulator. The solenoid assembly may need to be removed before performing this operation (Figure 6.1).
6. Remove the NG fuel jet (loosen counter clockwise) from the outlet port.
7. Remove the LP fuel jet (loosen counter clockwise) from the jet keeper port on the side of the regulator housing. Install this jet into the outlet port in the regulator casting.

NOTE:

The jet sizes are stamped on the individual jets. The larger jet size is used for running on NG.

8. Install the previously removed NG jet into the jet keeper port on the side of the regulator housing.

9. Install the previously removed black pipe onto the outlet port of the demand regulator. Use pipe sealant on the pipe threads.
10. Reverse steps 1-4 in this procedure to reactivate the demand regulator.
11. Follow the instructions in the Control Panel section.

⚠ DANGER!

⚠ Serious injury, including death, or damage will occur if not configured properly. Please consult an Authorized Dealer with any questions.

Figure 6.1 — Reconfigure the Fuel System

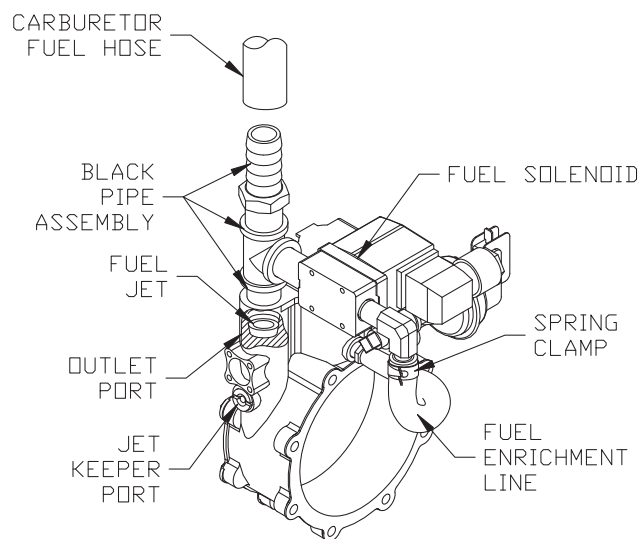

CONTROL PANEL

The FUEL TYPE must be reconfigured in the control panel to finalize the conversion process. This generator is configured at the factory to operate on natural gas. If conversion to LP is required, please complete the mechanical conversion process and then call 888-9ACTIVATE for the control panel password. This fuel selection conversion is required to be password protected by Environmental Protection Agency [EPA] regulations.

⚠ CAUTION!

⚠ Whenever the Generator's Fuel Regulator is converted from one Fuel type to the other, the Control Panel must be reconfigured for the correct fuel type. Failure to convert both the Regulator and Control Panel will result in decreased performance and an increase in emissions, and is a violation of EPA regulations.

ALTERNATOR AC LEAD CONNECTIONS

The electrical wires in the unit's AC connection (lower) panel should be installed according to the number of leads and the voltage/phase required for the application. The voltage and phase are described on the generator data label. The number of lead wires can be identified using the Specifications section and the power output rating on the generator data label. For example, if the generator produces 130kW, 277/480 Volt, 3-phase power, the generator has 12 alternator output leads. Figure 7.3 describes the stator power winding connection for the generator.

FOUR-LEAD, SINGLE-PHASE STATOR

Four-lead alternators (see Figure 7.1) are designed to supply electrical loads with voltage code "A" (240V, 1-phase, 60 Hz). Electrical power is produced in the stator power windings. These windings were connected at the factory to the main circuit breaker as shown in Figure 7.1.

The rated voltage between each circuit breaker terminal is 240V. The rated voltage between each circuit breaker terminal and the neutral point 00 is 120V.

Figure 7.1 — Four-lead, Single-phase Stator

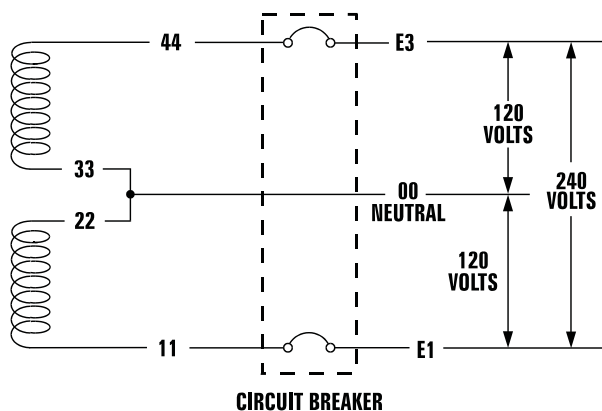

ALTERNATOR POWER WINDING CONNECTIONS

3-PHASE ALTERNATORS ("Y" CONFIGURATION)

The Stationary Emergency Generator is designed to supply 3-phase electrical loads. Electric power is produced in the alternator power windings. These windings were connected at the factory to the main circuit breaker with a "Y" configuration as shown in Figures 7.2 through 7.6.

The rated voltage between circuit breaker terminals E1-E2, E1-E3 and E2-E3 is 480V, 208V or 600V depending on the model.

The rated voltage between each circuit breaker terminal and the neutral point 00 is 277V, 120V, or 346V depending on the model.

Figure 7.2 — Stator Power Winding Connections - 3-phase, 277/480V (6 Lead)

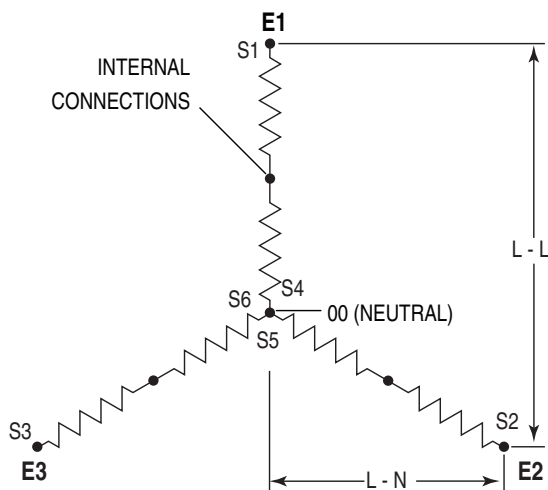
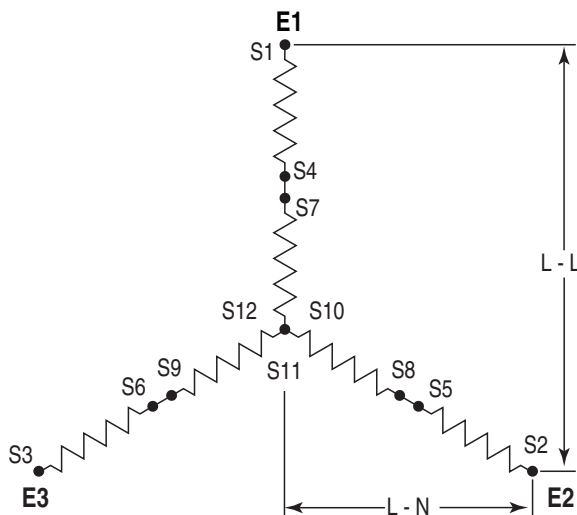

Figure 7.3 — Stator Power Winding Connections - 3-phase, 277/480V (12 Lead)



General Information

Figure 7.4 — Stator Power Winding Connections - 3-phase, 120/208V (6 Lead)

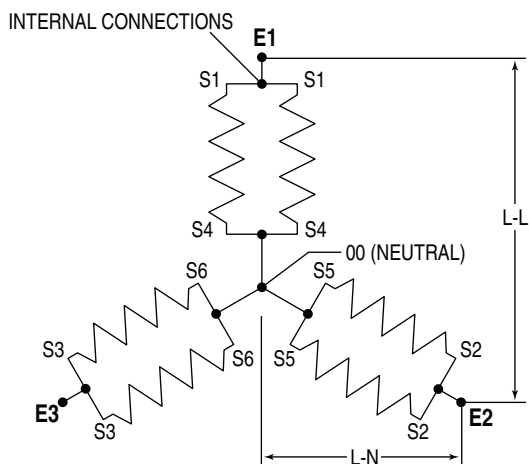

Figure 7.5 — Stator Power Winding Connections - 3-phase, 120/208V (12 Lead)

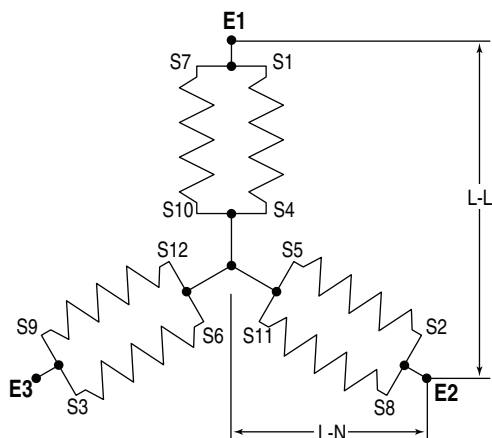
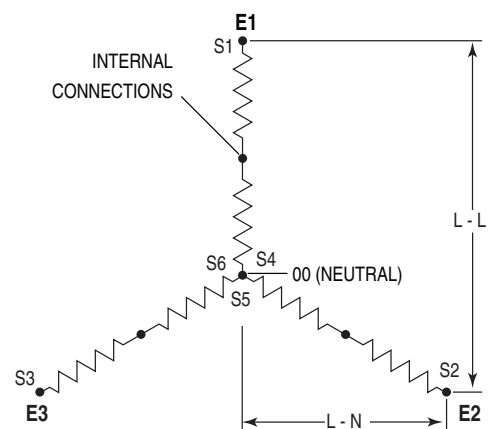

Figure 7.6 — Stator Power Winding Connections - 3-phase, 346/600V (6 Lead)



3-PHASE ALTERNATORS ("DELTA" CONFIGURATION)

The Stationary Emergency Generator is designed to supply 3-phase electrical loads. Electric power is produced in the alternator power windings. These windings were connected at the factory to the main circuit breaker with a "Delta" configuration as shown in Figures 7.7 and 7.8.

The rated voltage between circuit breaker terminals E1-E2, E1-E3 and E2-E3 is 240V.

The rated voltage between E1 or E3 and the neutral point 00 is 120V.

Figure 7.7 — Stator Power Winding Connections - 3-phase, 120/240V (6 Lead)

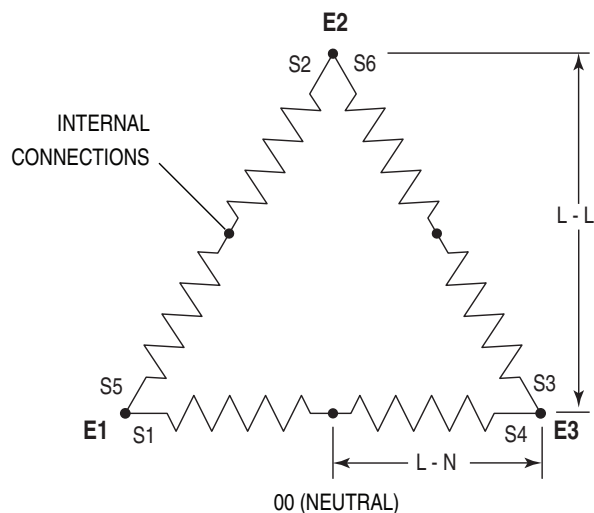
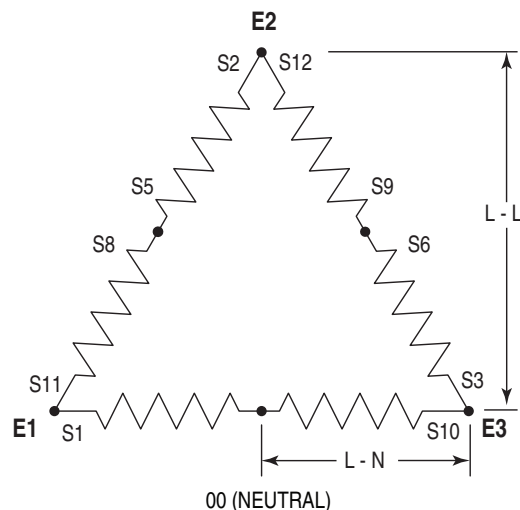

Figure 7.8 — Stator Power Winding Connections - 3-phase, 120/240V (12 Lead)



CONTROL PANEL INTERFACE

USING THE AUTO/OFF/MANUAL SWITCH

⚠ WARNING!

⚠ With the switch set to AUTO, the engine may crank and start at any time without warning. Such automatic starting occurs when utility power source voltage drops below a preset level or during the normal exercise cycle. To prevent possible injury that might be caused by such sudden starts, always set the switch to OFF and remove the fuse before working on or around the generator or transfer switch. Then, place a “DO NOT OPERATE” tag on the generator panel and on the transfer switch.

1. “AUTO” Position – Selecting this switch activates fully automatic system operation. It also allows the unit to automatically start and exercise the engine every seven days with the setting of the exercise timer (see the Setting the Exercise Timer section).
2. “OFF” Position – This switch position shuts down the engine. This position also prevents automatic operation.
3. “MANUAL” Position – Set the switch to MANUAL to crank and start the engine. Transfer to standby power will not occur unless there is a utility failure.

ACTIVATE THE GENERATOR

When battery power is applied to the generator during the installation process, the controller will turn ON and the LCD screen will illuminate. However, the generator still needs to be activated before it will automatically run in the event of a power outage.

Activating the generator is a simple one time process that is guided by the controller screen prompts. Once the product is activated, the controller screen will not prompt you again, even if you disconnect the generator battery.

To obtain the activation code, record the generator serial number and log onto www.activategen.com or call 1-888-9ACTIVATE and follow the steps to retrieve the activation code.

After obtaining your activation code, please complete the following steps at the generator’s control panel in the Activation Chart on the following page.

NOTE:

The generator will only run in manual until the passcode has been entered.

Upon power up, this controller will go through a system self test which will check for the presence of utility voltage on the DC circuits. This is done to prevent damage if the installer mistakenly connects AC utility power sense wires into the DC terminal block. If utility voltage is detected, the controller will display a warning message and lock out the generator, preventing damage to the controller. Power to the controller must be removed to clear this warning.

Utility voltage must be turned on and present at the N1 and N2 terminals inside the generator control panel for this test to be performed and pass.

NOTE:

DAMAGE CAUSED BY MISWIRING OF THE INTERCONNECT WIRES IS NOT WARRANTABLE!

This test will be performed each time the controller is powered up.

Next, the user must enter the minimum settings to operate. These settings are current date and time and exercise day and time. The maintenance intervals will be initialized (i.e. started) the first time the clock is set. If the clock is never set at power up, the maintenance intervals will be reset every time power is applied.

If a subsequent power loss (loss of battery power) occurs the Installation assistant will operate upon power restoration. The self test routine will be run and then the customer will be required to re-enter the time and date, as this is not retained during a power loss. The unit will not require re-activation.



DISPLAY INTERFACE MENUS

The LCD display is organized as detailed below:

- The “Home” page, this page is the default page which will be displayed if no keys are pressed for 30 seconds. This page normally shows the current Status message and the current date and time. The highest priority active Alarm and/or Warning will be automatically posted on this page as well as flashing the backlight when such an event is detected. In the case of multiple Alarms or Warnings, only the first message will be displayed. To clear an Alarm or Warning, see the Protection Systems section - Clear Alarm.
- The display backlight is normally off. If the user presses any key, the backlight will come on automatically and remain on for 30 seconds after the last key was pressed.
- The “Main Menu” page will allow the user to navigate to all other pages or sub-menus by using the Left/Right and Enter keys. This page can be accessed at any time with several presses of the dedicated Escape key. Each press of the Escape key takes you back to the previous menu until the main menu is reached. This page displays the following options: HISTORY; STATUS; EDIT; AND DEBUG. (See the Appendix - “Menu System”.)

Control Panel

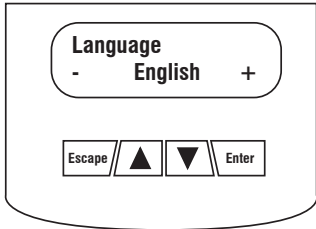
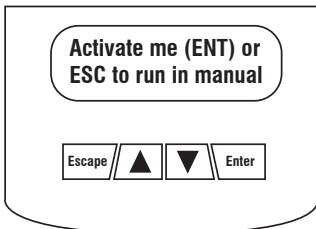
ACTIVATION CHART

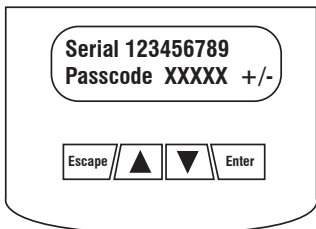
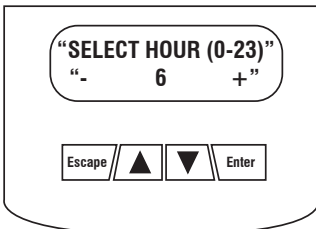
CHOOSE LANGUAGE		TROUBLESHOOTING
<p>Display Reads:</p> 	<p>Use ARROW keys to scroll to desired language. Press ENTER to select.</p>	<p>If the wrong language is chosen, it can be changed later using the “edit” menu.</p>
<p>Display Reads:</p> 	<p>Press ENTER to begin the activation process.</p>	<p>If ESCAPE is pressed instead of ENTER, your generator will only run in manual mode (for test purposes) and NOT ACTIVATED will be displayed. You will need to remove the generator control panel fuse AND disconnect the T1, N1 and N2 connector in the external connection box (if equipped); or disconnect utility input (main breaker) to the transfer switch for 3-5 seconds and reconnect, then begin with Step 1.</p>
<p>Display Reads:</p> 	<p>If you do not have your activation code, go to www.activategen.com or call 1-888-9ACTIVATE (922-8482). If you already have your activation code, wait 3-5 seconds for the next display.</p>	
ENTER ACTIVATION CODE (Passcode)		TROUBLESHOOTING
<p>Display Reads:</p> 	<p>Use ARROW keys to scroll and find the first number of your Activation Code. Press ENTER to select. Repeat this step until all digits have been entered. Use ESCAPE to correct previous digits.</p>	
<p>Display Reads:</p> 	<p>Activation is complete when all digits are entered above and your screen shows this display. Follow the controller prompts to continue setting the time function. Refer to your Owner’s Manual with questions.</p>	<p>What happens if “Wrong Passcode Try Again” appears? Re-enter the activation code. If a second attempt is unsuccessful, check the number against the code given on activategen.com. If it is correct and the generator will not accept it, contact 1-888-9ACTIVATE (922-8482).</p>

Control Panel

INSTALLATION ASSISTANT

Interconnect System Self Test Feature (follow the on-screen prompts).

Upon power up, this controller will go through a system self test which will check for the presence of utility voltage on the DC circuits. This is done to prevent damage if the installer mistakenly connects AC utility power sense wires into the DC terminal block. If utility voltage is detected, the controller will display a warning message and lock out the generator, preventing damage to the controller. Power to the controller must be removed to clear this warning.

Utility voltage must be turned on and present at the N1 and N2 terminals inside the generator control panel for this test to be performed and pass.

NOTE:

DAMAGE CAUSED BY MISWIRING OF THE INTERCONNECT WIRES IS NOT WARRANTABLE!

This test will be performed each time the controller is powered up.

Upon first power up of the generator, the display interface will begin an installation assistant. The assistant will prompt the user to set the minimum settings to operate. These settings are simply: Current Date/Time and Exercise Day/Time. The maintenance intervals will be initialized when the exercise time is entered.

The exercise settings can be changed at any time via the "EDIT" menu (see Appendix, "Menu System").

If the 12 volt battery is disconnected or the fuse removed, the Installation Assistant will operate upon power restoration. The only difference is the display will only prompt the customer for the current Time and Date.

IF THE INSTALLER TESTS THE GENERATOR PRIOR TO INSTALLATION, PRESS THE "ENTER" KEY TO AVOID SETTING UP THE EXERCISE TIME. THIS WILL ENSURE THAT WHEN THE CUSTOMER POWERS UP THE UNIT, HE WILL STILL BE PROMPTED TO ENTER AN EXERCISE TIME.

SETTING THE EXERCISE TIMER

This generator is equipped with an exercise timer. Once it is set, the generator will start and exercise every seven days, on the day of the week and at the time of day specified. During this exercise period, the unit runs for approximately 12 minutes and then shuts down. Transfer of loads to the generator output does not occur during the exercise cycle unless utility power is lost.

LOW SPEED EXERCISE

The standard start sequence will be initiated.

- All 1800 rpm units will exercise at 1400 RPM
- All 3600 rpm units will exercise at 1800 RPM

If utility is lost during exercise the controller will do the following:

- Wait for the "line interrupt period" for utility to return. If utility returns within the "line interrupt period", continue to exercise at low RPM.

- If utility is still lost after the "line interrupt period", run the engine up to normal RPM and transfer the load. At this time the controller will exit the exercise routine and assume full automatic operation.

USER ADJUSTABLE SETTINGS

Setting	Factory Default	Minimum Setting	Maximum Setting	Increment
Exercise time	2 pm	00:00 (12 am)	23:59 (11:59 pm)	1 min
Exercise day	Wed	Sun	Sat	1 day
Current Time	12 am	00:00 (12 am)	23:59 (11:59 pm)	1 min
Current Day	Sun	Sun	Sat	1 day
Current Month	Jan	Jan	Dec	1 month
Current Year	2008	2008	2100	1 year
Language	English	French	Spanish	N/A
Contrast	80%	0%	100%	1%

FUEL CONVERSION

For fuel conversion steps, refer to the GenSpec section, RECONFIGURING THE FUEL SYSTEM.

OPERATION

This system is intended to supply standby power in the event of a utility failure. The control system will monitor the utility voltage to determine if stand-by power is required. Should the utility voltage fail, the generator will start and run normally, detaching from the utility and supplying the customer load from the generator. When utility power returns, the controller will re-transfer the customer load back to utility and shut down the generator.

AUTOMATIC TRANSFER OPERATION

To select automatic operation, do the following:

1. Make sure the transfer switch main contacts are set to their UTILITY position, i.e., loads connected to the utility power source.
2. Be sure that normal UTILITY power source voltage is available to transfer switch terminal lugs N1 and N2 (Refer to the Electrical Data section).
3. Set the generator's AUTO/OFF/MANUAL switch to AUTO.
4. Set the generator's main circuit breaker to its ON (or CLOSED) position.

With the preceding steps complete, the generator will start automatically when utility source voltage drops below a preset level. After the unit starts, loads are transferred to the standby power source. Refer to the Sequence of Automatic Operation section.

SEQUENCE OF AUTOMATIC OPERATION

Initial Conditions: Generator in Auto ready to run, load being supplied by the Utility Source through the transfer switch.

1. When the utility voltage fails (falls below 60% of nominal), a 10-30 second (programmable) "line interrupt" delay timer is started. The factory set time delay is 10 seconds. If at the end of the line interrupt time the utility voltage is above 60% the engine will not crank. If the utility voltage is still below the 60% of nominal at the end of the line interrupt time, the unit will crank and start. If the unit cranks for more than 10 seconds and the utility voltage rises above 80% of nominal (programmed pickup voltage) and the unit has not started, the crank cycle will abort.
2. As soon as the unit starts a 5 second "warm-up" timer is initiated. When the warm-up timer expires the control will transfer the load to the generator (through the RTS switch) if the utility voltage is less than 80% of nominal. If the utility voltage is greater than the 80% of nominal at the end of the warm-up time the load will not be transferred to the generator and a one minute low-speed cool down period will start. At the end of the one minute cool down period the generator will stop.
3. Once the unit is running and the switch has transferred the load to the generator the unit will monitor utility voltage. When utility voltage returns (above the programmable pickup voltage, normally 80% of nominal), a 15 second "Return to Utility" timer will start. At the end of the return to utility time, if the utility voltage is still above the pickup voltage, the unit will transfer the load back to the utility source and run the unit through a one minute cool down period. When the cool down period is over the unit will shut down and be ready for the next outage.
4. If during the cool down period utility voltage should fall below 60% of nominal the 5 second warm-up timer is initiated and the unit will transfer the load back to the generator and continue to monitor the utility.

CRANK CYCLES AND OVERCRANK SHUTDOWN

If the unit fails to start during a cranking period it will display the Overcrank Shutdown Alarm. The system will control the cranking cycles as follows:

The first crank cycle is a 16 second crank time followed by a 7 second rest. The next 5 cycles will be 7 seconds of cranking time each followed by a 7 second rest time.

If the unit fails to start by the end of the 6 crank/rest cycles the Overcrank Shutdown Alarm will display and the unit will not attempt to crank until the alarm is reset.

AUTO START

This unit is designed to automatically start in the event of a utility failure or brown out condition. Brown out is defined as utility voltage less than 60% nominal, while utility is considered good when it is restored to at least the pickup value, 80% of nominal. These levels are fixed. The "Line Interrupt period" is an adjustable parameter by the dealer. If 2-wire start mode is activated, the unit will start when 2-wire start is active.

MANUAL START

Allows the user to start and run the generator manually.

Transfer of the load to the generator will occur if utility is lost while the unit is running in the manual mode (only if activated).

ALARM AND WARNING MESSAGES

Alarms are defined as "Latching" which means they must be cleared before the alarm message on the screen will clear. They can be of type "Shutdown" or not and are logged in the alarm log. Alarms are all annunciated on the display).

Warnings are "Non Latching" meaning the message automatically clears when the warning condition goes away. Warnings can not be of type "Shutdown" but they are logged in the alarm log. Warnings are all annunciated on the display.

LOW OIL PRESSURE SHUTDOWN ALARM

There is a 10 second delay before oil pressure is monitored.

HIGH COOLANT TEMPERATURE SHUTDOWN ALARM

There is a 10 second delay before engine temperature is monitored.

Once running there is a 1/4 second delay before shut down. The limit is set at 125° C or 257° F.

OVERCRANK SHUTDOWN ALARM

Occurs if the engine has not started within the specified crank cycle.

OVERSPEED SHUTDOWN ALARM

Warning indicator is measured and calculated by the microprocessor. Overspeed is defined as +20% of nominal engine speed for 3 seconds, or +25% immediate.

Nominal engine speed = 60.0 Hz

RPM SENSOR FAILURE SHUTDOWN ALARM

During cranking: If the board does not see a valid RPM signal within four (4) seconds of cranking it will shut down and lock out on RPM sensor loss.

During running: If the RPM signal is lost for one full second the board will shut the engine down, wait 15 seconds, then re-crank the engine if in AUTO, it will not re-crank in MANUAL.

If no RPM signal is detected within the first four (4) seconds of cranking, the control board will shut the engine down and latch out on RPM sensor loss.

If the RPM signal is detected the engine will start and run normally. If the RPM signal is subsequently lost the control board will try two more re-cranks before latching out and flashing the RPM Sensor Failure message (if it is in AUTO).

Control Panel

Figure 1 – Generator Control Panel

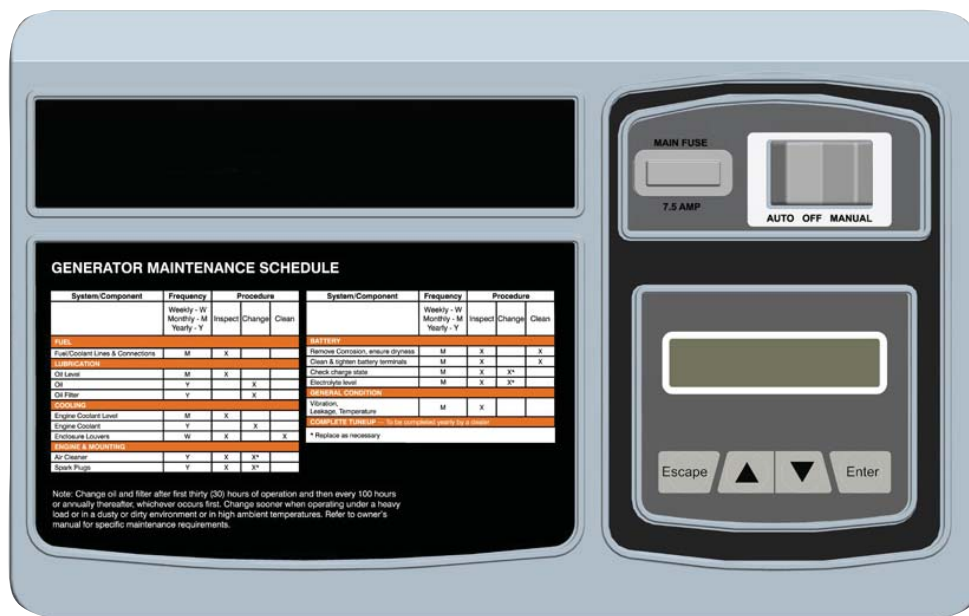

GENERATOR MAINTENANCE SCHEDULE

System/Component	Frequency			Procedure			System/Component	Frequency			Procedure		
	Weekly - W	Monthly - M	Yearly - Y	Inspect	Change	Clear		Weekly - W	Monthly - M	Yearly - Y	Inspect	Change	Clear
FILTER													
Exhaust/Control Lines & Connections	M	X					Replace	M	X				
LUBRICATION							Remove Corrosion, ensure dryness	M	X			X	
Oil Level	M	X					Clean & tighten battery terminals	M	X			X	
Oil	Y		X				Check charge state	M	X	X			
Oil Filter	Y		X				Electrolyte level	M	X	X			
WATERPUMP CONNECTIONS													
Waterpump	M	X					Waterpump	M	X				
Engine Coolant Level	M	X					Lockstep Temperature	M	X				
Engine Coolant	Y		X				* COMPLETE TUNEUP - To be completed yearly by a dealer						
Exhausture Louvers	W	X	X				* Reduce as necessary						
REPAIRS & MAINTENANCE													
Air Cleaner	Y	X	X										
Spark Plugs	Y	X	X										

Note: Change oil and filter after first thirty (30) hours of operation and then every 100 hours or annually thereafter, whichever occurs first. Change sooner when operating under a heavy load or in a dusty or dirty environment or in high ambient temperatures. Refer to owner's manual for specific maintenance requirements.

CHECK ENGINE MESSAGE

The control system has detected an emissions related fault. This fault cannot be cleared using the control panel interface. The unit will continue to operate in automatic mode. Contact your local servicing dealer.

UNDER-FREQUENCY SHUTDOWN ALARM

After starting, if the generator stays under frequency for more than 30 seconds, it will shutdown.

LOW BATTERY ALARM

While running, if the average battery voltage falls below 11.9 volts for one (1) minute, the low battery alarm will be displayed.

LOW BATTERY WARNING

The microprocessor will continually monitor the battery voltage and display the Low Battery Voltage message if the battery voltage falls below 12.2 Volts for one (1) minute.

No other action is taken on a low battery warning condition. The warning will automatically clear if the battery voltage rises above 12.2 volts.

NOTE:

The battery sentinel is a separate feature that monitors battery condition.

LOW COOLANT LEVEL ALARM

This is a shutdown alarm. The sensor will be continuously monitored. If an error condition is seen for five (5) consecutive seconds, the alarm will be displayed.

MISSING CAM PULSE ALARM

This is a shutdown alarm. The alarm will activate after five (5) seconds of continuously missing cam pulses.

MISSING CRANK PULSE ALARM

This is a shutdown alarm. The alarm will activate after 12 consecutive revs where crank pulses are missing.

LOW FUEL PRESSURE WARNING

Fuel pressure is monitored by a digital sensor with a fixed setpoint of below five (5) inches water column.

GOVERNOR SENSOR FAULT ALARM

The governor position is monitored by an analog feedback signal. If the throttle position is seen outside of the normal operating range, a shutdown alarm is displayed. If the throttle is commanded to move, and no movement is seen, a shutdown alarm is displayed.

WIRING ERROR ALARM

When power is first applied to the controller, the software will perform a check on the wiring of the transfer output, and ensure it does not have high voltage on the wire. If this is the case, it will signal a miswire alarm and will not run. The test can be skipped by use of the escape key.

UNDERVOLTAGE ALARM

If the generator voltage falls below 60% for >5 seconds, an alarm will be issued.

Control Panel

OVERVOLTAGE ALARM

If the generator voltage rises above 110% for >3 seconds, an alarm will be issued.

If the generator voltage rises above 130% for >0.2 seconds, an alarm will be issued.

INTERNAL FAILURE SHUTDOWN ALARM

Any internal failure that can be detected such as corrupted firmware will cause this shutdown alarm. This alarm cannot be cleared.

CANBUS ALARM

Where applicable, if the Canbus communications link fails to communicate, a “Canbus Alarm” will be generated. This only applies to systems with external ignition modules. The alarm may be generated if:

1. The physical link is broken.
2. The Ignition Module fails or resets.
3. The Nexus Controller fails or resets.
4. Having the Battery Chargers 120 VAC connected without a battery installed.
5. A blown 10 amp Ignition Module fuse (approximately 12 inches away from the starter).
6. A blown 25 amp system fuse (located approximately 12 inches away from the DC alternator).

NOTE:

The “Canbus Alarm” will not clear on its own. To clear the alarm, press the “enter” key to acknowledge the alarm. The alarm will clear and if the fault is still present, the alarm will reoccur.

IGNITION ALARM

When an ignition alarm occurs, a generic message “Ignition Fault” will be displayed as the fault code.

MAINTENANCE WARNING

When a maintenance period expires, a warning message will be posted. The warning can be reset by hitting the Enter key. Resetting will clear the warning and reset the maintenance counters for the condition annunciated. The history log will reflect the maintenance warning.

ALARM CANCEL

When the generator is shut down due to a latching alarm, the Auto /Off/ Manual switch must be set to the off position and the ENTER key pressed to unlatch any active fault and clear the corresponding fault alarm message.

COMMON ALARM RELAY

The common alarm relay will be activated if there is a shutdown alarm. It will not activate on warnings or indicate that the Auto/Off/ Manual switch is in the OFF position. The OFF position will clear the alarms and the relay. The relay will not be used to indicate a generator is not activated.

The common alarm connections are wired to a set of potential-free (dry) contacts on the Nexus controller board. These Normally Open (N.O.) contacts close when an alarm condition occurs and are used to activate a remote signaling device. The circuit is rated for a maximum of 130mA at 24 VDC. The connections are a short set of free hanging wires that exit the engine harness loom directly behind the Nexus Control Panel and are labeled numbers 209 and 210.

MAINTENANCE ALERTS

Maintenance alerts will be provided for these conditions.

SERVICE SCHEDULE ‘A’

Inspect Accessory Drive Alert	1yr / 100hrs*
Coolant Change & Flush	1yr / 100hrs
Inspect Spark Plugs Alert	1yr / 100hrs
Change Oil & Filter Alert	1yr / 100hrs*
Inspect Battery Alert	1yr / 100hrs
Change / Inspect Air Filter Alert	1yr / 100hrs
Clean/Inspect Air Inlet & Exhaust	6mo / 50hrs*
* Items require a 3 month / 30 hour break-in change or check.	

SERVICE SCHEDULE ‘B’

Change / Inspect spark plugs alert	2yr/ 250hr
------------------------------------	------------

MENU SYSTEM

Control Panel

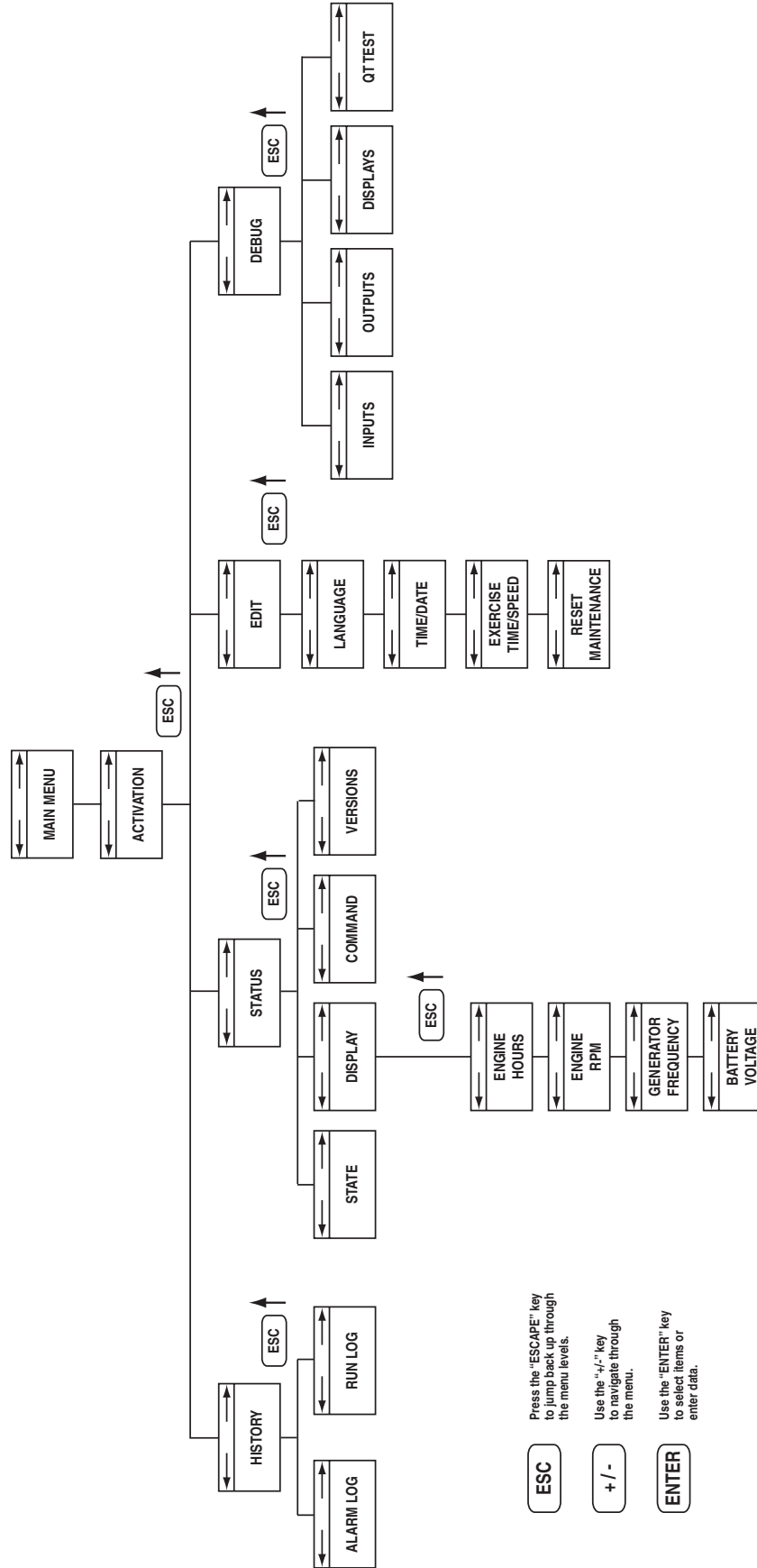

STATIONARY EMERGENCY GENERATOR CONTROL AND OPERATION

Refer to the appropriate control panel operator's manual for this unit.

OPERATING UNIT WITH MANUAL TRANSFER SWITCH

If the Stationary Emergency Generator was installed in conjunction with a transfer switch capable of manual operation only, the following procedure applies. A manually operated transfer switch is one that will not provide automatic start-up and does not include an intelligence circuit.

ENGINE START-UP AND TRANSFER

For additional information, refer to the applicable control panel manual for this unit, as well as any literature pertaining to the specific transfer switch.

⚠ DANGER!

⚠ The Maintenance Disconnect Switch and the AUTO/OFF/MANUAL switches (if so equipped) must be set properly, or the generator will crank and start as soon as the utility power to the transfer switch is turned off. Refer to applicable control panel and transfer switch manuals for more information.

⚠ Do not proceed until certain that utility source voltage is available to the transfer switch and the transfer switch main contacts are set to UTILITY.

⚠ Do not attempt manual operation until all power supplies to the transfer switch have been positively turned off, or extremely dangerous - possibly lethal - electrical shock will result.

⚠ Transfer switch enclosure doors should be kept closed and locked. Only authorized personnel should be allowed access to the transfer switch interior. Extremely high and dangerous voltages are present in the transfer switch.

In order to transfer load from the utility source to the generator, follow these directions:

- Turn OFF or disconnect the utility power circuit to the transfer switch, using the means provided (such as the utility source main line circuit breaker).
- Set the transfer handle to its UTILITY (NORMAL) position with load circuits connected to the utility power supply.
- Set the generator's main line circuit breaker to its OFF (or OPEN) position.
- Start the generator.

⚠ CAUTION!

⚠ Do not crank the engine continuously for longer than 30 seconds, or the heat may damage the starter motor.

- Let engine stabilize and warm up.
- Check all applicable instrument and gauge readings. When certain that all readings are correct, move the transfer switch manual handle to the STANDBY (or EMERGENCY STANDBY) position, i.e., load circuits supplied by the generator.
- Set the generator's main line circuit breaker to its ON (or CLOSED) position.
- Load circuits are now powered by the generator.

RETRANSFER AND SHUTDOWN

For additional information, refer to the applicable control panel manual for this unit, as well as any literature pertaining to the specific transfer switch.

To transfer the load back to the utility power source and shut down the generator, follow these directions:

- Set the generator's main line circuit breaker to its OFF (or OPEN) position.
- Manually move the transfer switch handle to its UTILITY (NORMAL) position, i.e., load circuits connected to the utility.
- Turn ON the utility power supply to the transfer switch, using the means provided (such as the utility power source main line circuit breaker).
- Let the generator run at no-load for a few minutes to stabilize internal temperatures.
- Shut down the generator.

OPERATING UNIT WITH AUTOMATIC TRANSFER SWITCH

If the Stationary Emergency Generator has been installed with an automatic transfer switch, the engine may be started and stopped automatically or manually.

NOTE:

Refer to the applicable manual for your transfer switch and to "Transfer Switch Start Signal Connections". In addition, please note the dangers under "Engine Start-up and Transfer."

GENERAL MAINTENANCE

⚠ WARNING!

⚠ Before working on the Stationary Emergency Generator, ensure the following:

- The AUTO/OFF/MANUAL switch is in the OFF position.
- The control panel fuse has been removed from the control box.
- The 120VAC supply to the battery charger is switched OFF.
- The negative battery cable has been removed.

CHECK ENGINE OIL

Check engine crankcase oil level (Figure 10.1) according to the Service Schedule and SIB10-10-L24G.

- Remove oil dipstick and wipe dry with a clean, lint-free cloth.
- Install oil dipstick, then remove again.
- Oil should be between FULL and ADD marks.
- If oil level is below the dipstick ADD mark, remove oil fill cap-. Add the recommended oil to bring oil level up to the FULL mark. DO NOT FILL ABOVE THE "FULL" MARK. See "Engine Oil Recommendations" for recommended oils.

Figure 10.1 - Oil Dipstick and Oil Fill Cap

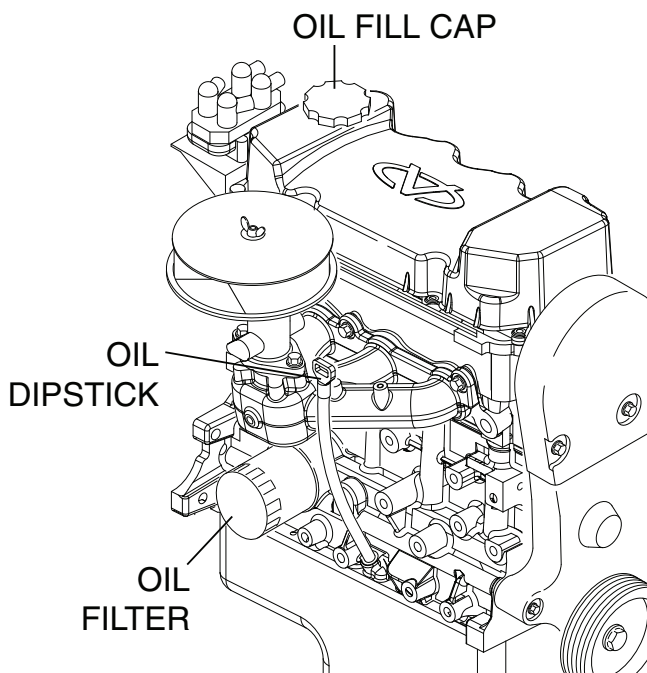

CHANGING ENGINE OIL

⚠ CAUTION!

⚠ Hot oil may cause burns. Allow engine to cool before draining oil. Avoid prolonged or repeated skin exposure with used oil. Thoroughly wash exposed areas with soap.

Refer to the Service Schedule for engine oil and filter change frequencies.

Drain the oil while the engine is still warm from running. This means warm up the engine, shut it down and drain immediately as follows:

1. Remove the drain hose from its retaining clip or cut the zip-tie securing the oil drain hose.
2. Loosen and remove OIL DRAIN HOSE CAP. Drain oil completely into suitable container.
3. When all oil has drained, install and tighten OIL DRAIN HOSE CAP and secure drain hose with a new zip-tie, or place the hose in its retaining clip.
4. Turn OIL FILTER (Figure 10.1) counterclockwise and remove. Properly dispose of old filter.
5. Apply light coating of new engine oil to seal of new oil filter. Install FILTER and tighten by hand only. DO NOT OVER TIGHTEN.
6. Remove OIL FILL CAP and add recommended oil. Crankcase oil capacity is listed in the "Specifications" section.

⚠ CAUTION!

⚠ After refilling the crankcase with oil, always check oil level on dipstick. NEVER OPERATE ENGINE WITH OIL BELOW THE DIPSTICK "ADD" MARK.

7. Start engine and check for oil leaks.
8. Shut OFF engine and wait 10 minutes for the oil to settle down into the oil pan. Recheck oil level on dipstick. DO NOT fill above the dipstick "FULL" mark.
9. Dispose of used oil at a proper collection center.

COOLING INTAKE/OUTLET

Air intake and outlet openings in the generator compartment must be open and unobstructed for continued proper operation. This includes such obstructions as high grass, weeds, brush, leaves and snow.

Without sufficient cooling and ventilating air flow, the engine/generator quickly overheats, which causes it to shut down. (See the installation diagram.)

⚠ WARNING!

⚠ The exhaust system parts from this product get extremely hot and remains hot after shutdown. High grass, weeds, brush, leaves, etc. must remain clear of the exhaust. Such materials may ignite and burn from the heat of the exhaust system.

INSPECT COOLING SYSTEM

- Inspect engine cooling system. See the Service Schedule.
- Check hoses for damage, deterioration, leaks, etc. Correct any discrepancies found.
- Check hose clamps for tightness.

ENGINE COOLANT

Check coolant level in coolant recovery bottle. See the Specifications and Service Schedule sections.

- Add recommended coolant mixture as necessary.
- Periodically remove radiator pressure cap (only when engine has cooled down) to make sure the coolant recovery system is functioning properly. Coolant should be at bottom of radiator filler neck. If coolant level is low, inspect gasket in radiator pressure cap. Replace cap, if necessary. To have pressure cap tested, contact a Service Facility. Inspect cooling system and coolant recovery system for leaks.

COOLANT CHANGE

Every year, have a service facility drain, flush and refill the cooling system. See the Specifications and Service Schedule for cooling system recommendations.

OVERLOAD PROTECTION FOR ENGINE DC ELECTRICAL SYSTEM

Engine cranking, start up and running are controlled by a solid state Engine Controller circuit board. Battery voltage is delivered to that circuit board via the control panel fuse. This overcurrent protection device will open if the circuit is overloaded.

⚠ CAUTION!

- ⚠ **If a circuit breaker opens or a fuse element melts, find the cause of the overload before resetting the circuit breaker or replacing the fuse.**

EXERCISE SYSTEM

Starts the Stationary Emergency Generator engine once every seven days and lets it run for 12 minutes.

PERFORM VISUAL INSPECTION

Complete a thorough visual inspection of the entire engine-generator monthly. Look for obvious damage, loose, missing or corroded nuts, bolts and other fasteners. Look for fuel, oil or coolant leaks.

INSPECT EXHAUST SYSTEM

Inspect the exhaust system at least once every year. Check all exhaust system pipes, mufflers, clamps, etc. for condition, tightness, leaks, security, damage.

CHECK FAN BELT

- Inspect fan belts every year. Replace any damaged, deteriorated, worn or otherwise defective belt.
- Check fan belt tension. Thumb pressure, exerted midway between pulleys, should deflect about 3/8 to 5/8 of an inch. Adjust belt tension as required.
- Check fan belt alignment (see Figure 10.2).

Figure 10.2 – Fan Belt

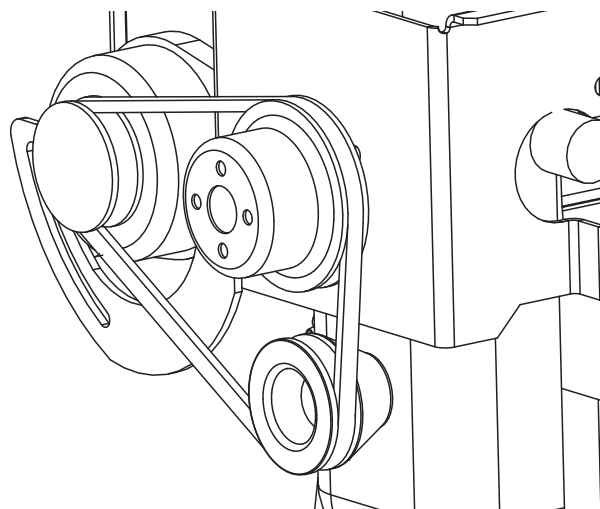

INSPECT ENGINE GOVERNOR

Visually inspect electronic governor.

⚠ DANGER!

- ⚠ **Do not attempt to adjust the governor. Only qualified service facilities should adjust the governor. Excessively high operating speeds are dangerous and increase the risk of personal injury. Low speeds impose a heavy load on the engine when adequate engine power is not available and may shorten engine life. Correct rated frequency and voltage are supplied only at the proper governed speed. Some connected electrical load devices may be damaged by incorrect frequency and/or voltage. Only qualified service technicians should adjust the governed speed.**

CHANGING THE ENGINE AIR FILTER

To replace the engine air filter, remove the air filter cover and replace the air filter making sure it is positioned properly before reattaching the cover (Figure 10.3).

See the Service Schedule for air filter maintenance.

Figure 10.3 – Engine Air Filter

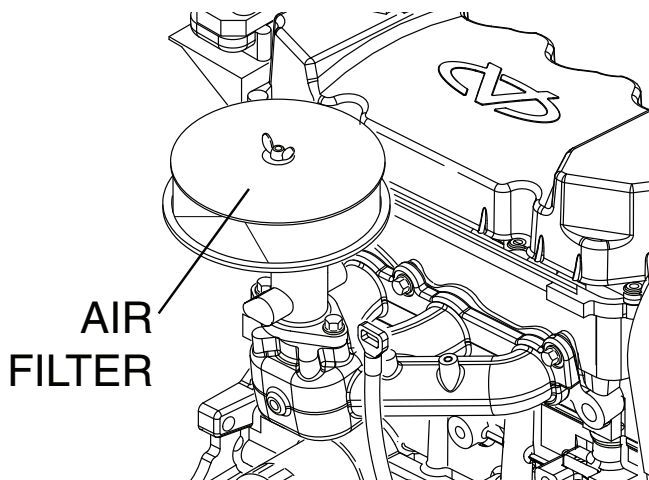

SPARK PLUGS

Reset the spark plug gap or replace the spark plugs as necessary.

1. Clean the area around the base of the spark plugs to keep dirt and debris out of the engine. Clean by scraping or washing using a wire brush and commercial solvent. Do not blast the spark plugs to clean.
2. Remove the spark plugs and check the condition. Replace the spark plugs if worn or if reuse is questionable. See the “Service Schedule” section for recommended inspection.
3. Check the spark plug gap using a wire feeler gauge. See the Specifications section for the required spark plug gap.

BATTERY MAINTENANCE

The battery should be inspected per the Service Schedule section. The following procedure should be followed for inspection:

1. Inspect the battery posts and cables for tightness and corrosion. Tighten and clean as necessary.
2. Check the battery fluid level of unsealed batteries and, if necessary, fill with **DISTILLED WATER ONLY**. **DO NOT USE TAP WATER IN BATTERIES**.
3. Have the state of charge and condition checked. This should be done with an automotive-type battery hydrometer.

⚠ DANGER!

⚠ Storage batteries give off explosive hydrogen gas. This gas can form an explosive mixture around the battery for several hours after charging. The slightest spark can ignite the gas and cause an explosion. Such an explosion can shatter the battery and cause blindness or other injury. Any area that houses a storage battery must be properly ventilated. Do not allow smoking, open flame, sparks or any spark producing tools or equipment near the battery.

⚠ Battery electrolyte fluid is an extremely corrosive sulfuric acid solution that can cause severe burns. Do not permit fluid to contact eyes, skin, clothing, painted surfaces, etc. Wear protective goggles, protective clothing and gloves when handling a battery. If fluid is spilled, flush the affected area immediately with clear water.

⚠ Do not use any jumper cables or booster battery to crank and start the generator engine. If the battery has completely discharged, remove it from the generator for recharging.

⚠ WARNING!

⚠ Be sure the AUTO/OFF/MANUAL switch is set to the OFF position, before connecting the battery cables. If the switch is set to AUTO or MANUAL, the generator can crank and start as soon as the battery cables are connected.

⚠ Be sure the 120VAC power supply to the battery is turned OFF, or sparking may occur at the battery posts as the cables are attached and cause an explosion.

BATTERY REPLACEMENT

NOTE:

Unit DOES NOT include battery.

When supplying or replacing the battery, the recommended number and type of battery is listed in the Specifications Section.

NOTE:

The BCI number should be located directly on the battery.

BATTERY FLUID

Check battery electrolyte fluid based on the Service Schedule. Fluid should cover separators in all battery cells. If fluid level is low, add distilled water to cover tops of separators. **DO NOT USE TAP WATER IN BATTERY.**

CLEANING THE STATIONARY EMERGENCY GENERATOR

Keep the generator as clean and as dry as possible. Dirt and moisture that accumulates on internal generator windings have an adverse effect on insulation resistance.

Periodically clean generator exterior surfaces. A soft brush may be used to loosen caked on dirt. Use a vacuum system or dry, low pressure air to remove any accumulations of dirt. The generator is housed inside an all-weather enclosure, clean the enclosure with a soft, damp cloth or sponge and water.

Once each year have the generator cleaned and inspected by a Service Dealer. That dealer will use dry, low pressure air to clean internal windings.

Finally, have the insulation resistance of stator and rotor windings checked. If insulation resistances are excessively low, the generator may require drying.

Service Schedule

SERVICE SCHEDULE

System / Component	Frequency	Procedure		
		Inspect	Change	Clean
	Weekly - W Monthly - M Yearly - Y			
Fuel				
Fuel Lines & Connections	M	X		
Lubrication				
Oil Level	M	X*		
Oil	Y		X**	
Oil Filter	Y		X**	
Cooling				
Engine Coolant Lines & Connections	M	X		
Engine Coolant Level	M	X		
Engine Coolant	Y		X	
Enclosure Louvers	W	X		X
Engine				
Air Cleaner	Y	X	X***	
Spark Plugs	Y	X	X***	
Battery				
Remove Corrosion, Ensure Dryness	M	X		X
Clean & Tighten Battery Terminals	M	X		X
Check Charge State	M	X	X***	
Check Electrolyte Level	M	X	X***	
General Condition				
Vibration, Noise, Leakage, Temperature	M	X		
Generator System				
Complete Tune-up and System Inspection	Y	To be completed by an Authorized Service Dealer.		
Footnotes				
* Inspect the oil level monthly or every 12 hours during continuous operation.				
** Change oil and oil filter after the first 30 hours of operation and then every 100 hours or annually thereafter, whichever occurs first. Change sooner when operating under heavy load or in a dusty or dirty environment or in high ambient temperatures.				
*** Replace as necessary.				

Troubleshooting

TROUBLESHOOTING GUIDE

PROBLEM	CAUSE	CORRECTION
Engine won't crank.	<ol style="list-style-type: none"> 1. Control panel 7.5 amp fuse blown. 2. Loose or corroded or defective battery cables. 3. Defective starter contactor. 4. Defective starter motor. 5. Dead or Defective Battery. 	<ol style="list-style-type: none"> 1. Replace fuse.* 2. Tighten, clean or replace battery cables as necessary.* 3. Replace contactor.* 4. Replace starter motor.* 5. Remove, change or replace battery.*
Engine cranks but won't start.	<ol style="list-style-type: none"> 1. Out of fuel. 2. Fuel solenoid (FS) is defective 3. Spark plugs defective. 	<ol style="list-style-type: none"> 1. Replenish fuel/turn on fuel valve. 2. Replace solenoid.* 3. Clean, regap or replace plugs.
Engine starts hard, runs rough.	<ol style="list-style-type: none"> 1. Air cleaner plugged or damaged. 2. Defective spark plugs. 3. Fuel pressure incorrect. 4. Insufficient fuel supply. 5. Fuel system set to wrong fuel type. 	<ol style="list-style-type: none"> 1. Clean or replace as needed. 2. Clean, regap or replace plugs. 3. Confirm fuel pressure to regulator is as recommended in SPECIFICATIONS.* 4. Confirm fuel pressure to regualtor is as recommended in SPECIFICATIONS.* 5. Reconfigure the fuel system. (See RECONFIGURING THE FUEL SYSTEM in manual.*
Engine starts then shuts down.	<ol style="list-style-type: none"> 1. Engine oil level is low. 2. Engine is overheated. 3. Defective Low Oil Pressure Switch 4. Defective Coolant Temperature Switch 5. Defective Control Module circuit board. 6. Coolant Level is Low. 7. Defective Low Coolant Level Switch 	<ol style="list-style-type: none"> 1. Check oil and add oil as needed. 2. Check cooling system for leaks. 3. Replace switch.* 4. Replace switch.* 5. Replace board.* 6. Repair leak - Add coolant. 7. Replace Switch.*
AUTO/OFF/MANUAL Switch at OFF, engine continues to run.	<ol style="list-style-type: none"> 1. Defective AUTO/OFF/MANUAL switch 2. Defective Control Module circuit board 	<ol style="list-style-type: none"> 1. Replace board.* 2. Replace board.*
No AC output from generator.	<ol style="list-style-type: none"> 1. Main line circuit breaker is tripped/open. 2. Generator internal failure. 3. Thermal circuit breaker open. 	<ol style="list-style-type: none"> 1. Reset to ON/CLOSED. 2. * 3. Auto-reset - Wait 5 min. and attempt restart.

***Contact the nearest Dealer for assistance.**

Warranty

United States Environmental Protection Agency Warranty Statement (Stationary Emergency Spark-Ignited Generators)

Warranty Rights, Obligations and Coverage

The United States Environmental Protection Agency (EPA) and Generac Power Systems, Inc. (Generac) are pleased to explain the Emission Control System Warranty on your new stationary emergency engine. If during the warranty period, any emission control system or component on your engine is found defective in materials or workmanship, Generac will repair your engine at no cost to you for diagnosis, replacement parts and labor provided it be done by a Generac Authorized Warranty Service Facility. Your emission control system may include parts such as the fuel metering, ignition, and exhaust systems and other related emission related components listed below. Generac will warrant the emissions control systems on your 2009 and later model year engines provided there has been no abuse, neglect, unapproved modification or improper maintenance of your engine. For engines less than 130 HP the warranty period is two years from the date of sale to the ultimate purchaser. For engines greater than or equal to 130 HP the warranty period is three years from the date of the engine being placed into service.

Purchaser's/Owner's Warranty Responsibilities

As the engine purchaser/owner you are responsible for the following. 1.) The engine must be installed and configured in accordance to the Generac's installation specifications. 2.) The completion of all maintenance requirements listed in your Owner's Manual. 3.) Any engine setting adjustment must be done in accordance and consistent with the instructions in the Owner's Manual. 4.) Any emission control system or component must be maintained and operated appropriately in order to ensure proper operation of the engine and control system to minimize emissions at all times.

Generac may deny any/or all Emission Control System Warranty coverage or responsibility of the engine, or an emission control system or component on your engine thereof, if it has failed due to abuse, neglect, unapproved modification or improper maintenance, or the use of counterfeit and/or 'gray market' parts not made, supplied or approved by Generac. Warranty service can be arranged by contacting either your selling dealer or a Generac Authorized Warranty Service dealer, 1-800-333-1322 for the dealer nearest you. The purchaser/owner shall be responsible for any expenses or other charges incurred for service calls and/or transportation of the product to/from the inspection or repair facilities. The purchaser/owner shall be responsible for any and/or all damages or losses incurred while the engine is being transported/shipped for inspection or warranty repairs. Contact Generac Power Systems Inc. for additional Emission Control System Warranty related information, Generac Power Systems, Inc. P.O. Box 8, Waukesha, WI 53187, or call 1-800-333-1322 or www.generac.com.

Important Note

This warranty statement explains your rights and obligations under the Emission Control System Warranty, which is provided to you by Generac pursuant to federal law. Note that this warranty shall not apply to any incidental, consequential or indirect damages caused by defects in materials or workmanship or any delay in repair or replacement of the defective part(s). This warranty is in place of all other warranties, expressed or implied. Specifically, Generac makes no other warranties as to the merchantability or fitness for a particular purpose. Any implied warranties which are allowed by law, shall be limited in duration to the terms of the express warranty provided herein. Some states do not allow limitations on how long an implied warranty lasts, so the above limitation may not apply to you.

Emission Related Parts Include the Following (if so equipped)

- | | |
|---|---|
| 1) Fuel Metering System | 3) Ignition System Including |
| 1.1) Gasoline Carburetor Assembly And Internal Components A) Fuel Filter, B) Carburetor, C) Fuel Pump | A) Spark Plug, B) Ignition Module, C) Ignition Coil, D) Spark Plug Wires |
| 1.2) Carburetion Assembly And Its Components A) Fuel Controller, B) Carburetor And Its Gaskets, C) Mixer And It Gaskets, D) Primary Gas Regulator E) Liquid Vaporizer | 4) Exhaust System A) Catalyst Assembly, B) Exhaust Manifold, C) Muffler, D) Exhaust Pipe, E) Muffler Gasket |
| 1.3) Fuel Regulator | 5) Crankcase Breather Assembly Including A) Breather Connection Tube, B) Pcv Valve |
| 2) Air Induction System Including A) Intake Pipe/Manifold, B) Air Cleaner | 6) Oxygen Sensor |
| | 7) Diagnostic Emission-Control System |

Warranty

United States Environmental Protection Agency Compliance Requirements (Stationary Emergency Spark-Ignited Generators)

Purchaser's/Owner's Recordkeeping Responsibilities

The United States Environmental Protection Agency (EPA) and Generac Power Systems, Inc. (Generac) are pleased to explain your record-keeping requirements for compliance with Subpart JJJJ- Standards of Performance for Stationary Spark Ignition Internal Combustion Engines as listed in the Electronic Code of Federal Regulations Title 40 Part 60. As the engine purchaser/owner who operates and maintains their certified emergency stationary engine and emission control system according to applicable emission related guidelines as specified in this Owner's Manual, you are required to meet the following notification and recordkeeping requirements to demonstrate compliance. 1.) Maintain documentation that the engine is certified to meet emission standards. 2.) Recordkeeping of maintenance conducted. 3.) Recordkeeping of the provision allowing natural gas engines to operate using propane for a maximum of 100 hours per year as an alternate fuel solely during emergency operations provided the engine is not certified to operate on propane. 4.) Meet all compliance notifications submitted to the purchaser/owner and maintain all supporting documentation. 5.) Recordkeeping of hours of operation, including what classified the operation as emergency and how many hours are spent for non-emergency operation. For emergency engines greater than or equal to 130 HP, recordkeeping of hours of operation begins January 1, 2011. For emergency engines less than 130 HP, recordkeeping of hours of operation begins January 1, 2009; Engines are equipped with non-resettable hour meters to facilitate recordkeeping.

Specific Air Quality Management or Air Pollution Control Districts may have different and additional record keeping/reporting requirements. Your permit to construct and/or operate the engine may be contingent upon compliance with those requirements. Check with your local Air Quality Management or Air Pollution Control District for specific requirements.

Emergency stationary internal combustion engines (ICE) may be operated for the purpose of maintenance checks and readiness testing, provided that the tests are recommended by Federal, State or local government, Generac, or the insurance company associated with the engine. Maintenance checks and readiness testing of such units is limited to 100 hours per year. There is no time limit on the use of emergency stationary ICE in emergency situations. The purchaser/owner may petition the Administrator for approval of additional hours to be used for maintenance checks and readiness testing, but a petition is not required if the owner maintains records indicating that Federal, State, or local standards require maintenance and testing of emergency ICE beyond 100 hours per year. Emergency stationary ICE may operate up to 50 hours per year in non emergency situations, but those 50 hours are counted towards the 100 hours per year provided for maintenance and testing.

The 50 hours per year for non-emergency situations cannot be used for peak shaving or to generate income for a facility to supply power to an electric grid or otherwise supply power as part of a financial arrangement with another entity. For purchaser/owner of emergency engines, any operation other than emergency operation, maintenance and testing, and operation in non-emergency situations for 50 hours per year, as permitted in this section is prohibited.

If you operate and maintain your certified emergency stationary SI internal combustion engine and emissions control systems in accordance to the specifications and guidelines in this Owner's Manual EPA will not require engine performance testing. If not, your engine will be considered non-certified and you must demonstrate compliance according to Subpart JJJJ - Standards of Performance for Stationary Spark Ignition Internal Combustion Engines as listed in the Electronic Code of Federal Regulations Title 40 Part 60.

Emission-Related Installation Instructions

Your certified emergency stationary engine has pre-set emission control systems or components that require no adjustment. Inspection and replacement of an emissions related component is required to be done so in accordance with the requirements cited in the United States Environmental Protection Agency Warranty Statement or can be arranged by contacting either your selling dealer or a Generac Authorized Warranty Service dealer, 1-800-333-1322 for the dealer nearest you. Failing to follow these instructions when installing a certified engine in a piece of nonroad equipment violates federal law 40 CFR 1068.105 (b), subject to fines or penalties as described in the Clean Air Act.

GROUP A

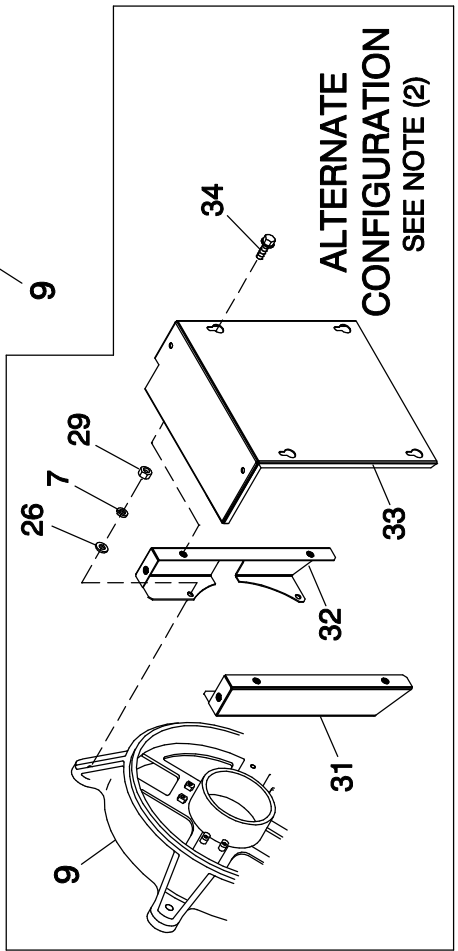
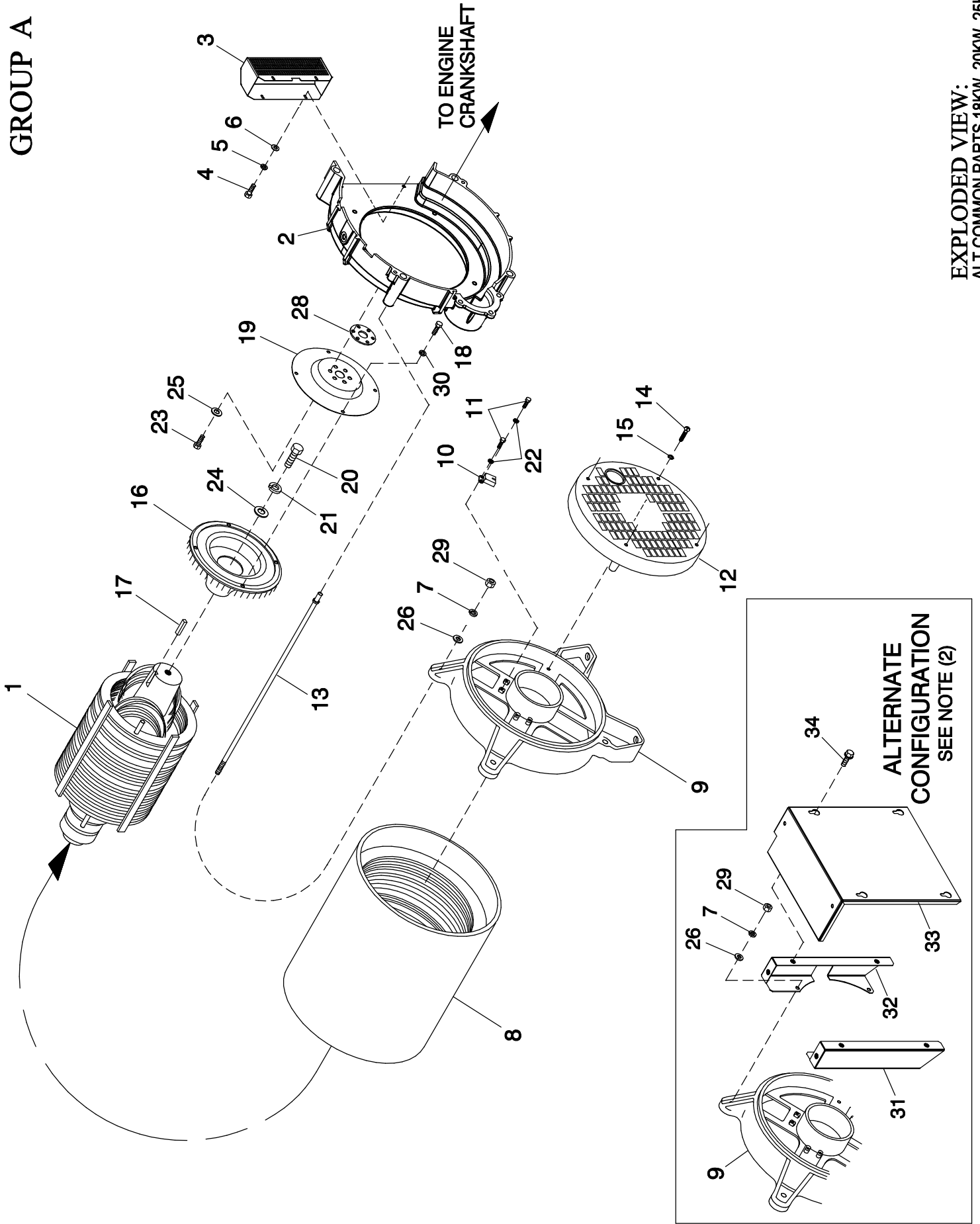

**ALTERNATE
CONFIGURATION
SEE NOTE (2)**

**EXPLODED VIEW:
ALT COMMON PARTS 18KW, 20KW, 25KW, & 30KW
DRAWING #: 0G4008**

EXPLODED VIEW: ALT COMMON PARTS 18KW, 20KW, 25KW, & 30KW

DRAWING #: 0G4008

GROUP A

APPLICABLE TO:

ITEM	PART #	QTY.	DESCRIPTION
1	0G4827	1	ASSY RTR 104 KD1 HI EFF (18KW)
	0G2927	1	RTR-102-20.0AD1 CPL (2006) (20KW)
	0G2827	1	ASSY RTR 25KW 2P (2006) (25KW)
	0G3451	1	ASSY RTR 30KW 2P 10"(2006)
2	0G0820A	1	HOUSING BLOWER LG PILOT
3	0G4452	1	BLOWER HOUSING SCREEN
4	020746	4	SCREW PPHM M5-0.8 X 8 ZINC
5	049226	4	WASHER LOCK M5
6	051713	4	WASHER FLAT M5
7	022129	4	WASHER LOCK M8-5/16
8	0G4825	1	ASSY STR 104-18AD1 HI EFF (18KW)
	0G4826	1	ASSY STR 104 18GD1 HI EFF (18KW)
	0G2926	1	STR-102-20.0AD1 CPL (2006) (20KW)
	0G3682	1	STR-102-20.0GD1 CPL (2006) (20KW)
	0G5584	1	STR-102-20.0JD1 CPL (2006) (20KW)
	0G3685	1	STR-102-20.0KD1 CPL (2006) (20KW)
	0G2826	1	ASSY STR 102 25AD1 (2006) (25KW)
	0G3683	1	STR-102-25.0GD1 CPL (2006) (25KW)
	0G6573	1	STR-102-25.0JD1 CPL (2006) (25KW)
	0G3686	1	STR-102-25.0KD1 CPL (2006) (25KW)
	0G3684	1	STR-102-30.0GD2 CPL (30KW)
	0G3687	1	STR-102-30.0KD2 CPL (30KW)
	0G5909	1	ASSY STR 102 30AD2 10" (30KW)
	0G6103	1	STR-102-30.0JD2
9	0A5382A	1	BEARING CARRIER REAR LG PILOT
10	075591	1	ASSY HOLDER BRUSH
11	051787	4	SCREW HHC M4-0.7 X 16 G8.8
12	0A5601A	1	COVER REAR BEARING
13	0G8827	4	STUD M8-1.25 475 LONG
	0G8827A	4	STUD M8-1.25 418 LONG
14	0A9375	4	SCREW RHM #10-24 X 2
15	022152	4	WASHER LOCK #10
16	0G4196	1	FLYWHEEL & RINGGEAR ASSY 1.6L
17	042558	1	KEY SQ 3/8 X 1 STEEL
18	0J6102	4	SCREW HHFC M10-1.5 X 16 C10.9
19	0G0965B	1	PLATE FLEX 1.6L R12.7
20	053607	1	SCREW HHC M12-1.75 X 35 G8.8
21	051769	1	WASHER LOCK M12
22	023365	4	WASHER SHAKEPROOF INT #8
(1) 23	0F3353	6	SCREW HHC M10-1.0 X 20 G10.9
24	072578	1	SPACER ROTOR SHAFT
25	0G3787	6	WASHER .41 ID .94 OD .12 THK
26	0A8830	4	WASHER FLAT .34 ID X .75 OD
27	077043E	1	FLEX CONDUIT 1" BLACK (NOT SHOWN)
28	0G2070	1	PLATE SPACER 14GA 1.6L (TO BE USED WITH ENGINE PLATE P/N 0G0834.)
	0G2070A	1	PLATE SPACER 16GA 1.6L (TO BE USED WITH ENGINE PLATE P/N 0G0834A.)
29	045771	4	NUT HEX M8-1.25 G8 CLEAR ZINC
30	0D8427	4	WASHER LOCK M10 RIBBED ZINC
(2)31	0J6853A	1	SUPPORT LH ALT COVER
(2)32	0J6853B	1	SUPPORT RH ALT COVER
(2)33	0J6853C	1	COVER REAR 10" ALT
(2)34	0C2454	6	SCREW HWHT M6-1 X 16 N WA Z/JS

(1) APPLY LOCTITE 242 BEFORE THREADING SCREW INTO CRANKSHAFT.

(2) ALTERNATE CONFIGURATION REQUIRES ALL NOTED PARTS.

GROUP A

225 AF

C1 DPE BREAKER SELECTION			
MODEL	RATING	ITEM 7 RATING	ITEM 7 PIN
22KW127KW - 1φ	3A	054502	
25KW130KW - 1φ	4.5A	046476	
25KW130KW - 3φ	5.5A	054450	
22KW127KW - 3φ	6A	046505	
22KW127KW - 1φ 50Hz	5A	046512	

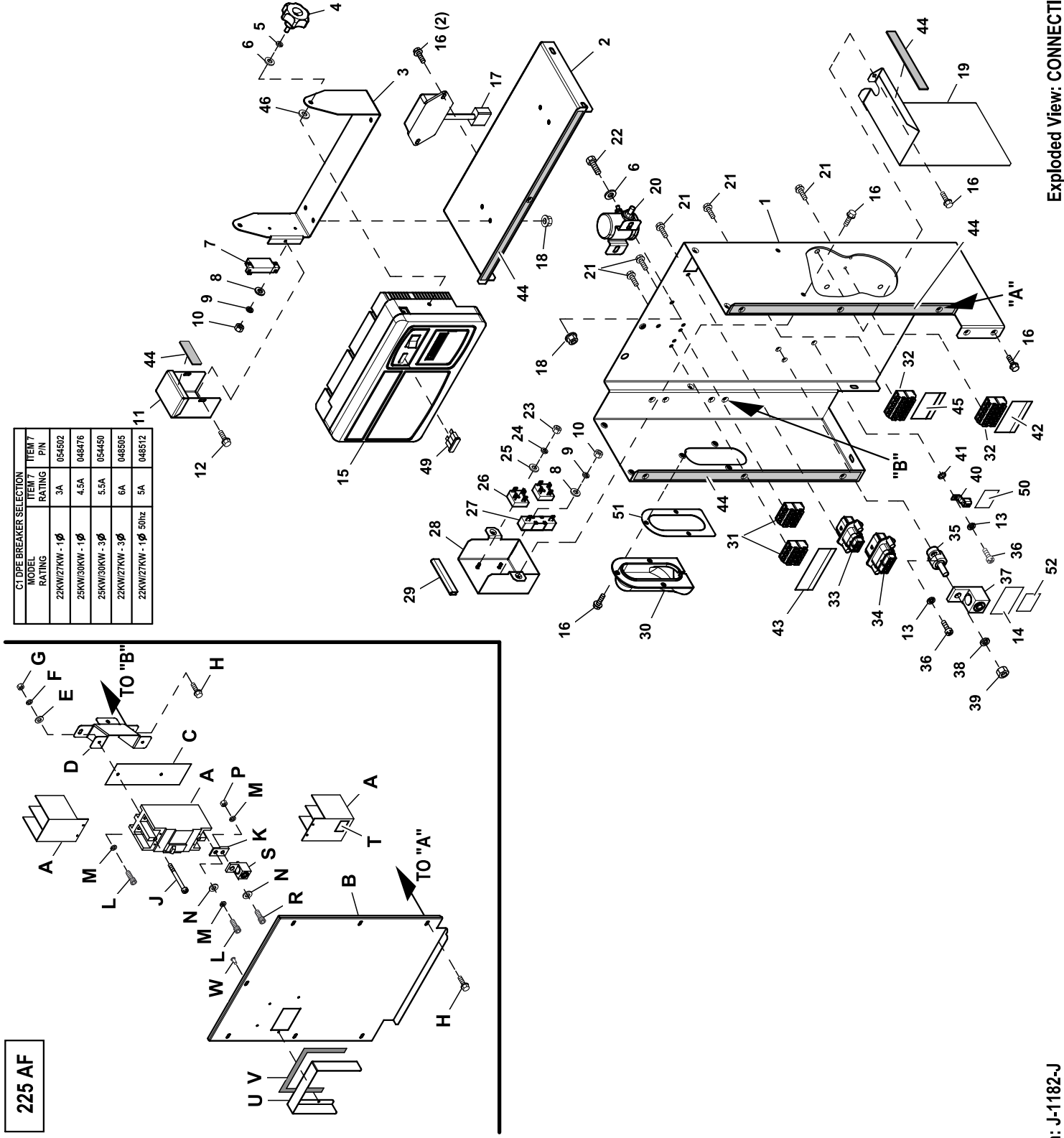

GROUP A

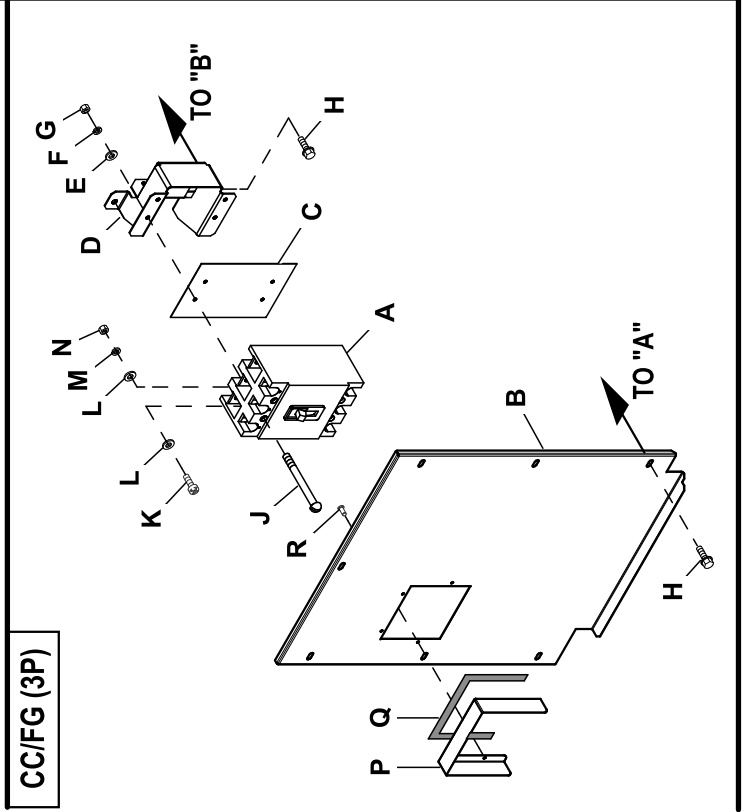
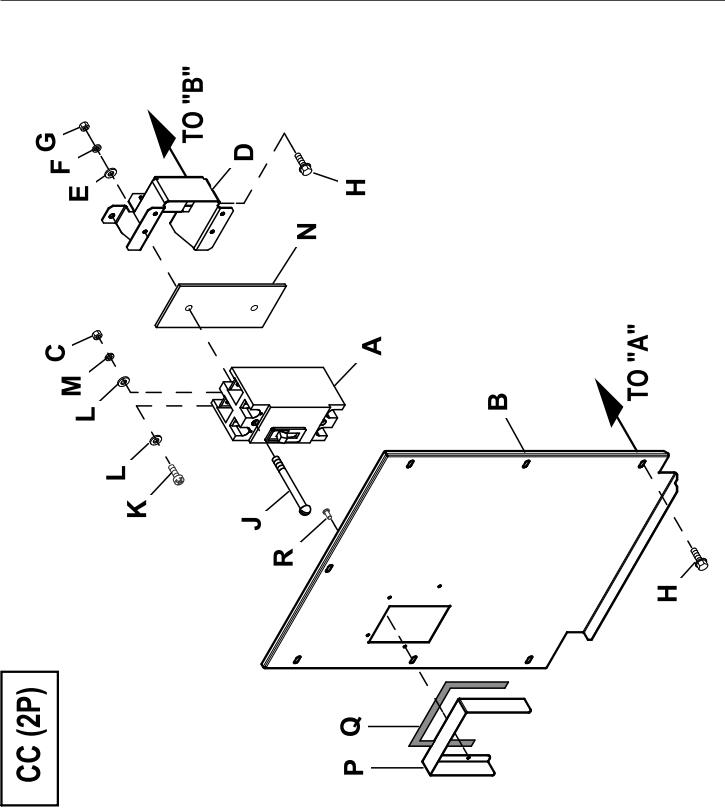

GROUP A

ED (3P)

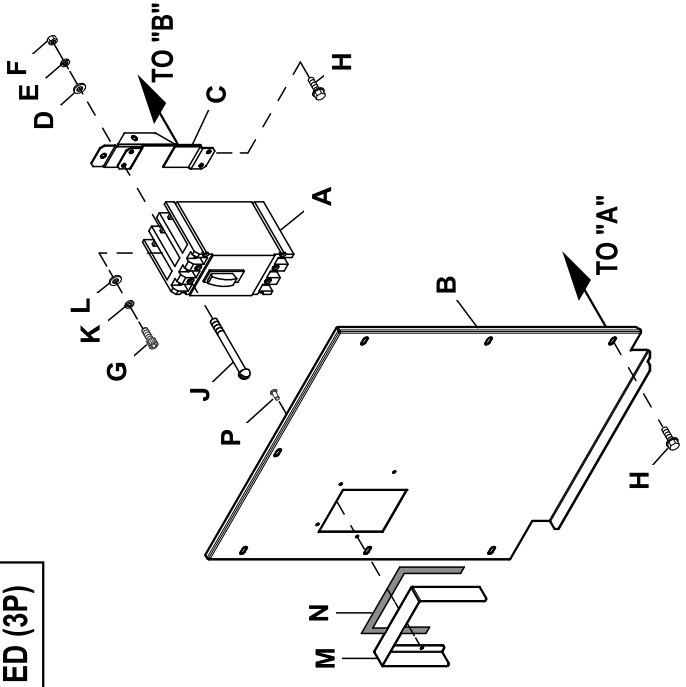

QN2

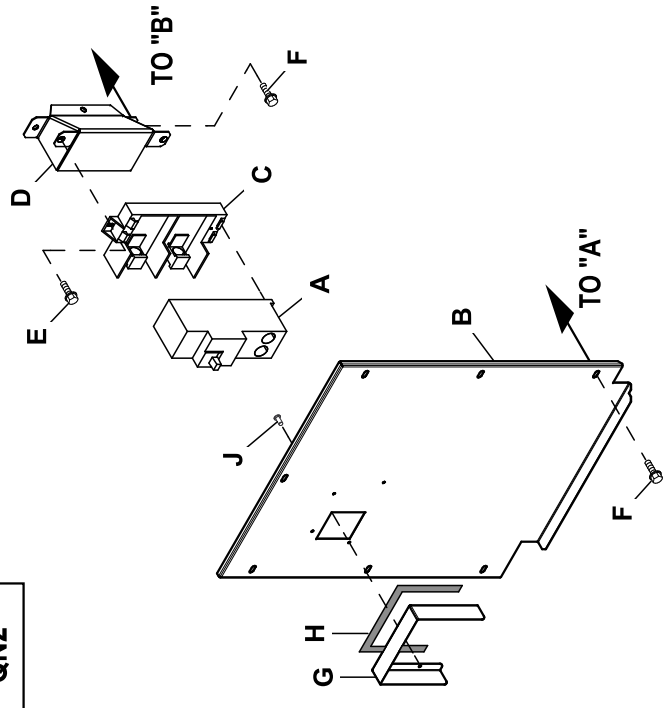

BQ (2P)

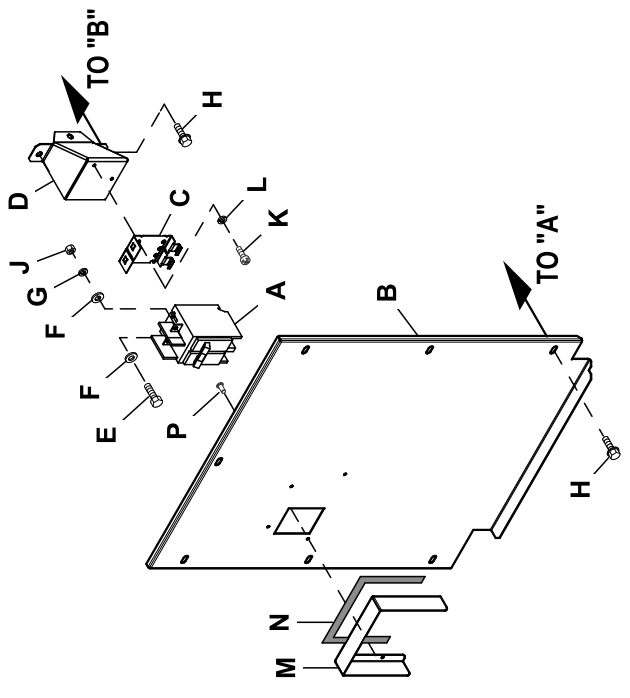

BQ (3P)

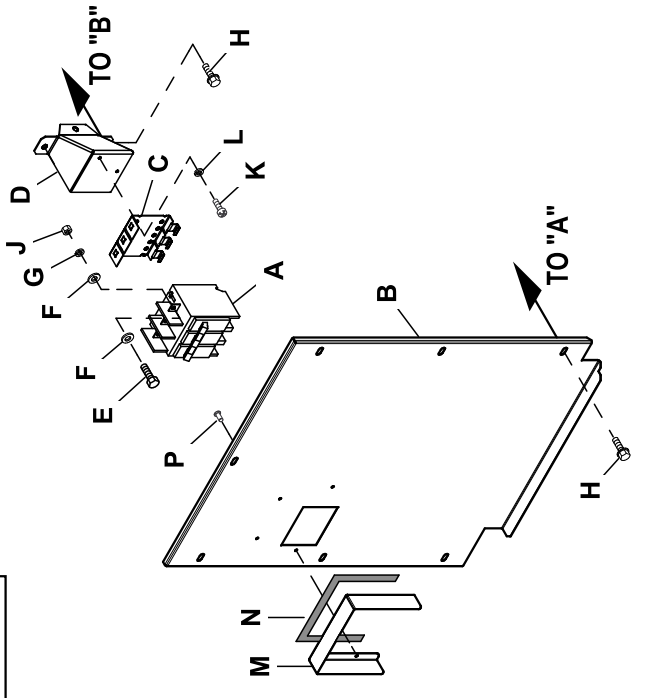

EXPLODED VIEW: CONNECTION BOX C1 CPL

DRAWING #: 0H7234

GROUP A

APPLICABLE TO:

ITEM	PART#	QTY.	DESCRIPTION
1	0H6795	1	CONBOX BACK/SIDES C1 CPL
2	0H6796	1	CONBOX TOP C1 CPL
(4)3	0H67330STOR	1	BRACKET GIMBAL CONTROL PNL RAW
4	0H7115	2	KNOB M6-1.0 CONTROL PANEL
5	022097	2	WASHER LOCK M6-1/4
6	022473	4	WASHER FLAT 1/4-M6 ZINC
(3)7	SEE CHART	1	CIRCUIT BREAKER
8	052777	3	WASHER FLAT M3
9	043182	3	WASHER LOCK M3
10	051714	3	NUT HEX M3-0.5 G8 CLEAR ZINC
(4)11	0H81040AS0R	1	COVER DPE BREAKER NEXUS
12	045764	2	SCREW HHTT M4-0.7 X 8 ZP
13	022264	3	WASHER LOCK #8-M4
14	0A9457	1	DECAL NEUTRAL
15	REF	1	ASSY CTRL PROGRAMMED
16	0C2454	18	SCREW HWHT M6-1 X 16 N WA Z/JS
(2)17	0A1354A	1	REGULATOR - DC ALT
18	0D3700	6	NUT FLANGE M6-1.0 NYLON
(4)19	0H88380STOR	1	SHIELD HIGH/LOW C1 RAW
20	056739	1	RELAY SOLENOID 12VDC PNL MNT
21	0F5458	12	SCREW HHSP #10 X 3/8 HI-LOW
22	042568	2	SCREW HHC M6-1.0 X 20 C8.8
23	051716	2	NUT HEX M5-0.8 G8 CLEAR ZINC
24	049226	2	WASHER LOCK M5
25	051713	2	WASHER FLAT M5
26	0D7177V	2	DIODE BRIDGE 1P 35A 1000V
27	0F5752F	1	RES WW 15R 5% 25W QK CONN
28	0H6267	1	COVER VOLTAGE SHIELD
29	056326	1	TRIM VINYL BLACK 1/8GP (3"LG)
30	0G3524	1	COVER BELL HOUSING CONBOX
(1)31	0D7393T	REF	TERM BLOCK 3P UL 12-20AWG
(1)32	0D7393U	REF	TERM BLOCK 4P UL 12-20AWG
(1)33	0F5376S0AR	REF	MX150L SLRRMNT 22-18 8P W/O GA
(1)34	0F5396S0AR	REF	MX150L SLRRMNT 22-18 12P W/OGA
35	057073	1	JUNCTION BLOCK 3/8-16
36	0C2265	3	SCREW PHTT M4-0.7 X 12 ZP
37	057329	1	LUG SLDLSS 350-#6X13/32 AL/CU
38	022237	1	WASHER LOCK 3/8
39	022241	1	NUT HEX 3/8-16 STEEL
40	025433	1	LUG SLDLSS #6-14 X 13/64 CU
41	023762	1	WASHER LOCK EXT #10 STL
42	0H7292	1	DECAL CUSTOMER CONTROL CONNECT
43	0H7293	1	DECAL CONBOX TB1 CONNECTIONS
44	029289	1	TAPE ELEC 1/2 FOAM (62" LG)
45	0J0489	1	DECAL CUSTOMER POWER CONNECT
46	0A2115	2	WASHER NYLON .257
47	0F6146	1	HANG TAG 2 WIRE START (NOT SHOWN)
48	0H6692	1	HARN CONBOX NEXUS (NOT SHOWN)
49	0D7178T	REF	FUSE ATO TYPE 7.5AMP (BROWN)
50	067210A	1	DECAL GROUND LUG
51	0J6701	1	GASKET WIRE ENTRY COVER
52	0H8006	1	DECAL CAUTION ELEC SHOCK SM

UL CIRCUIT BREAKER (225AF)

A	0G5249	REF	CB 150A 2 POLE 240V 225AF
B	0H6846	1	COVER CB G 225AF C1 CONBOX
C	0F8432A	1	INSULATOR CB 2P 225AF
D	0G5734	1	SPRT CIRCUIT BREAKER G 225AF
E	038150	2	WASHER FLAT #8 ZINC
F	022264	2	WASHER LOCK #8-M4
G	022471	2	NUT HEX #8-32 STEEL
H	0C2454	10	SCREW HWHT M6-1 X 16 N WA Z/JS
J	053640	2	SCREW RHM #8-32 X 3-1/4
K	0F8843	2	BUS BAR 200A LUG ADAPTOR
L	049897	4	SCREW SHC M8-1.25 X 20 G8

EXPLODED VIEW: CONNECTION BOX C1 CPL

DRAWING #: 0H7234

GROUP A

APPLICABLE TO:

ITEM	PART#	QTY.	DESCRIPTION
M	022129	6	WASHER LOCK M8-5/16
N	022145	4	WASHER FLAT 5/16-M8 ZINC
P	045771	2	NUT HEX M8-1.25 G8 CLEAR ZINC
R	058306	2	SCREW SHC M8-1.25 X 25 C12.9
S	0F8451	2	LUG SLDLSS 300 MCM-6 AL/CU
T	0G3259	1	DECAL TERMINAL SHOCK HZD BI
U	0J78230AS0R	1	SHIELD CB HANDLE CONBOX
V	029289	1	TAPE ELEC 1/2 FOAM
W	036261	4	RIVET POP .125 X .275 SS

(1) ITEMS INCLUDED WITH HARNESS P/N 0H6692.

(2) ITEMS USED ON 1.6L MODELS ONLY.

(3) SEE "C1 DPE BREAKER SELECTION" TABLE.

(4) SHEET METAL PARTS LISTED IN THE BOM TABLE ARE REPRESENTING GENERIC PARTS (NO COLOR)

- MANUFACTURING: FOR CORRECT MATERIAL AND COLOR REFER TO AS400 BOM.
- CUSTOMER: WHEN ORDERING REPLACEMENT PARTS ENTER BASE NUMBER (FIRST 6 DIGITS ONLY) IN THE SYSTEM FOR CORRECT MATERIAL AND COLOR (FOR REFERENCE SEE GUIDELINE 0H7169).

EXPLODED VIEW: CONNECTION BOX C1 CPL

DRAWING #: 0H7234

GROUP A

APPLICABLE TO:

ITEM	PART#	QTY.	DESCRIPTION
UL CIRCUIT BREAKER (CC 2P)			
A	0H4745	REF	CB 0100A 2P 240V E CC LL
	0H4746	REF	CB 0125A 2P 240V E CC LL
	0H4747	REF	CB 0150A 2P 240V E CC LL
B	0H6847	1	COVER CB E CC 2P C1 CONBOX
C	051716	2	NUT HEX M5-0.8 G8 CLEAR ZINC
D	0H4656	1	CIRCUIT BREAKER SUPPORT (CC)
E	038150	2	WASHER FLAT #8 ZINC
F	022264	2	WASHER LOCK #8-M4
G	022471	2	NUT HEX #8-32 STEEL
H	0C2454	10	SCREW HWHT M6-1 X 16 N WA Z/JS
J	053640	2	SCREW RHM #8-32 X 3-1/4
K	091526	2	SCREW PPHM M5-0.8 X 12 ZNC
L	023897	4	WASHER FLAT #10 ZINC
M	049226	2	WASHER LOCK M5
N	0H4698	1	INSULATOR CB 2P E TYPE CC
P	0J78230ASOR	1	SHIELD CB HANDLE CONBOX
Q	029289	1	TAPE ELEC 1/2 FOAM
R	036261	4	RIVET POP .125 X .275 SS
UL CIRCUIT BREAKER (CC/FG (3P))			
A	0H4913	REF	CB 0100 3P 240V E CC LL
	0H4914	REF	CB 0125 3P 240V E CC LL
	0H5488	REF	CB 0080 3P 600V E FG LL
	0H5489	REF	CB 0090 3P 600V E FG LL
B	0H7294	1	CB COVER E CC/FG 3P C1 CONBOX
C	0H4698A	1	INSULATOR CB 3P E TYPE CC/FG
D	0H4656	REF	CIRCUIT BREAKER SUPPORT (CC)
	0H5604	REF	CIRCUIT BREAKER SUPPORT (FG)
E	038150	4	WASHER FLAT #8 ZINC
F	022264	4	WASHER LOCK #8-M4
G	022471	4	NUT HEX #8-32 STEEL
H	0C2454	10	SCREW HWHT M6-1 X 16 N WA Z/JS
J	053640	4	SCREW RHM #8-32 X 3-1/4 (CC)
	0H5721	4	SCREW PPHM #8-32 X 1-3/4 ZINC (FG)
K	091526	3	SCREW PPHM M5-0.8 X 12 ZNC
L	023897	6	WASHER FLAT #10 ZINC
M	049226	3	WASHER LOCK M5
N	051716	3	NUT HEX M5-0.8 G8 CLEAR ZINC
P	0J78230ASOR	1	SHIELD CB HANDLE CONBOX
Q	029289	1	TAPE ELEC 1/2 FOAM
R	036261	4	RIVET POP .125 X .275 SS

EXPLODED VIEW: CONNECTION BOX C1 CPL

DRAWING #: 0H7234

GROUP A

APPLICABLE TO:

ITEM	PART#	QTY.	DESCRIPTION
UL CIRCUIT BREAKER (BQ 2P)			
A	0D5543	REF	CB 0090A 2P 240V S BQ2 LL
	0D5544	REF	CB 0100A 2P 240V S BQ2 LL
	0A2077	REF	CB 0125A 2P 240V S BQ2 LL
B	0H6842	1	COVER CB S BQ2 C1 CONBOX
C	0E7890	1	BRKT CB MTG BACK
D	0G4497	1	CIRCUIT BREAKER SUPPORT (BQ)
E	052619	2	SCREW HHC M5-0.8 X 20 G8.8
F	023897	4	WASHER FLAT #10 ZINC
G	049226	2	WASHER LOCK M5
H	0C2454	10	SCREW HWHT M6-1 X 16 N WA Z/JS
J	051716	2	NUT HEX M5-0.8 G8 CLEAR ZINC
K	0G9708	2	SCREW PHTT M4-0.7 X 8 ZP
L	022264	2	WASHER LOCK #8-M4
M	0J78230ASOR	1	SHIELD CB HANDLE CONBOX
N	029289	1	TAPE ELEC 1/2 FOAM
P	036261	4	RIVET POP .125 X .275 SS
UL CIRCUIT BREAKER (BQ 3P)			
A	062812	REF	CB 0080A 3P 240V S BQ3 LL
	053691	REF	CIRCT BRK 90 X 3 ITE BQ3-B090
	040532	REF	CB 0100A 3P 240V S BQ3 LL
B	0H6843	1	COVER CB S BQ3 C1 CONBOX
C	0E6002	1	MTG TRACK BQ SIEMENS CB 3P
D	0G4497	1	CIRCUIT BREAKER SUPPORT (BQ)
E	052619	3	SCREW HHC M5-0.8 X 20 G8.8
F	023897	6	WASHER FLAT #10 ZINC
G	049226	3	WASHER LOCK M5
H	0C2454	10	SCREW HWHT M6-1 X 16 N WA Z/JS
J	051716	3	NUT HEX M5-0.8 G8 CLEAR ZINC
K	0G9708	2	SCREW PHTT M4-0.7 X 8 ZP
L	022264	2	WASHER LOCK #8-M4
M	0J78230ASOR	1	SHIELD CB HANDLE CONBOX
N	029289	1	TAPE ELEC 1/2 FOAM
P	036261	4	RIVET POP .125 X .275 SS
UL CIRCUIT BREAKER (ED 3P)			
A	0D5552	REF	CB 0050A 3P 480V S ED4 LL
	0D5556	REF	CB 0090A 3P 480V S ED4 LL
	0D5557	REF	CB 0100A 3P 480V S ED4 LL
	0D9693	REF	CB 0125A 3P 480V S ED4 LL
B	0H6844	1	COVER CB S ED3 C1 CONBOX
C	0G4498	1	CIRCUIT BREAKER SUPPORT (ED)
D	038150	4	WASHER FLAT #8 ZINC
E	022264	4	WASHER LOCK #8-M4
F	022471	4	NUT HEX #8-32 STEEL
G	0A8278	3	SCREW SHC 1/4-28 X 3/4 G8.8 NZ
H	0C2454	10	SCREW HWHT M6-1 X 16 N WA Z/JS
J	066715	4	SCREW RHM #8-32 X 4-1/2
K	022097	3	WASHER LOCK M6-1/4
L	0D5621	3	WASHER-STEP 1/2ODX9/32ID BRASS
M	0J78230ASOR	1	SHIELD CB HANDLE CONBOX
N	029289	1	TAPE ELEC 1/2 FOAM
P	036261	4	RIVET POP .125 X .275 SS
UL CIRCUIT BREAKER (QN2 2P)			
A	0E7283	REF	CB 0150A 2P 240V S QN2 LL
B	0H6845	1	COVER CB S QN2 C1 CONBOX
C	0E3664	1	BASE, QN CIRCUIT BREAKER
D	0G4112	1	BREAKER SUPPORT BRACKET 30KW
E	074908	2	SCREW HHTT M5-0.8 X 10 BP
F	0C2454	10	SCREW HWHT M6-1 X 16 N WA Z/JS
G	0J78230ASOR	1	SHIELD CB HANDLE CONBOX
H	029289	1	TAPE ELEC 1/2 FOAM
J	036261	4	RIVET POP .125 X .2

EXPLODED VIEW: CONNECTION BOX C1 CPL

DRAWING #: 0H7234

APPLICABLE TO:

GROUP A

THIS PAGE LEFT INTENTIONALLY BLANK

GROUP C

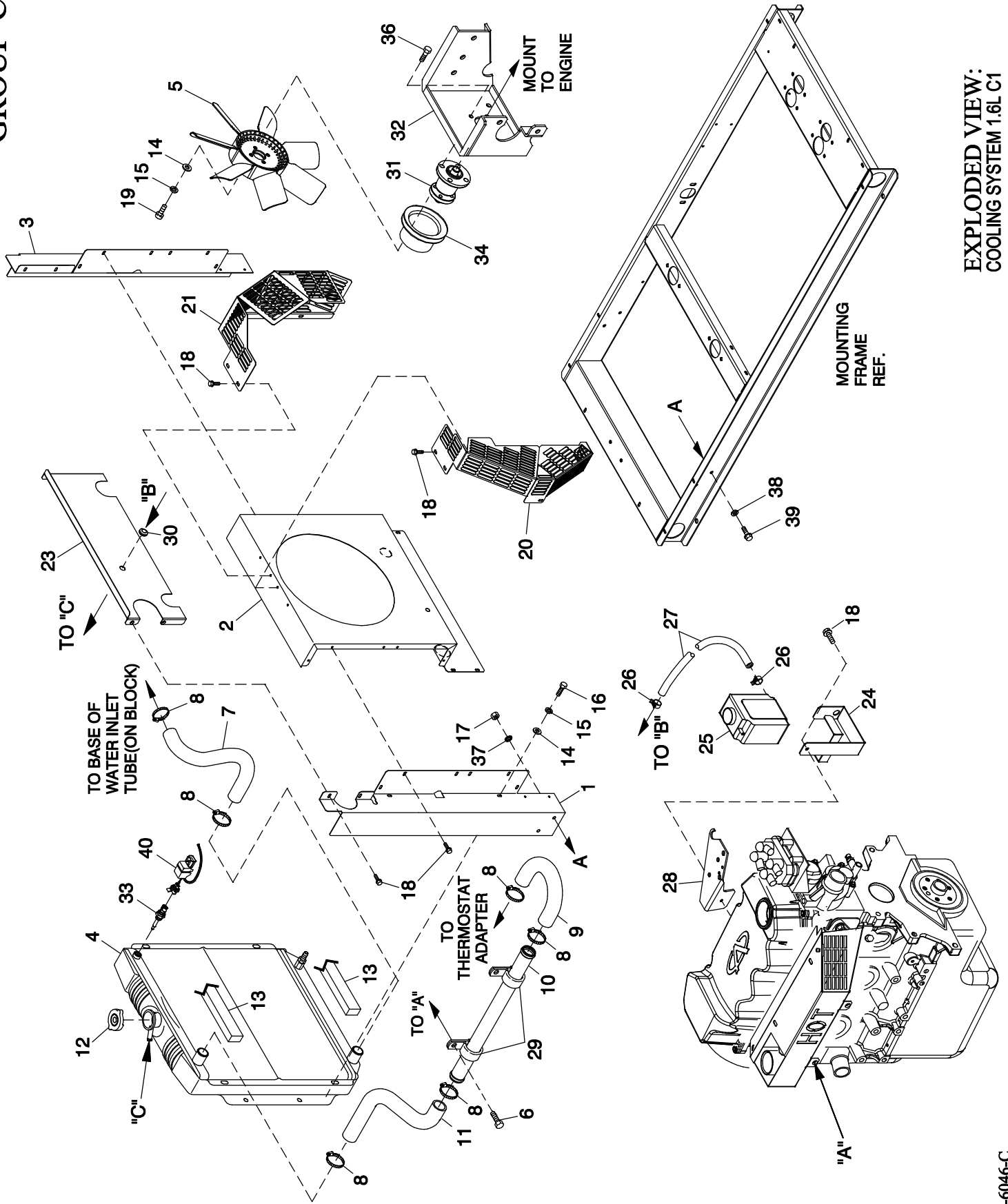

EXPLODED VIEW:
 COOLING SYSTEM 1.6L C1
 DRAWING #: 0G3428

EXPLODED VIEW: COOLING SYSTEM 1.6L C1

DRAWING #: 0G3428

GROUP C

APPLICABLE TO:

ITEM	PART #	QTY.	DESCRIPTION
1	0G3418	1	RADIATOR SUPPORT LH SIDE 1.6L
2	0G3421	1	VENTURI 1.6L
3	0G3419	1	RADIATOR SUPPORT RH SIDE 1.6L
4	0E9837B	1	RADIATOR 1.6L CHY
5	0G3553	1	FAN COOL 450MM DIA 7 BLADE
6	0E3257	2	SCREW HWHTF M6-1.0 X 16
7	0G4080	1	HOSE LOWER RADIATOR 1.6L
8	099502	6	CLAMP HOSE #24 B1.06-2.00
9	0G4070	1	HOSE REAR COOLANT 1.6L
10	0G4072	1	TUBE ENGINE COOLANT 1.6L
11	0G4071	1	HOSE UPPER RADIATOR 1.6L
12	046627	1	CAP RADIATOR
13	052250	2	TAPE FOAM 1 X 1 (24" LG)
14	022473	8	WASHER FLAT 1/4-M6 ZINC
15	022097	8	WASHER LOCK M6-1/4
16	0C8566	4	SCREW HHFC M6-1.0 X 20 G8.8
17	045771	4	NUT HEX M8-1.25 G8 CLEAR ZINC
18	0C2454A	28	SCREW THF M6-1 X 12 N WA Z/J
19	042568	4	SCREW HHC M6-1.0 X 20 G8.8
20	0G3573	1	GUARD FAN LH C1
21	0G3574	1	GUARD FAN RH C1
23	0G3420	1	RADIATOR BLOCK-OFF
24	080713	1	BRACKET COOLANT TANK
25	076749	1	TANK COOLANT RECOVERY
26	048031C	2	CLAMP HOSE BAND 1/4
27	029032	1	HOSE 9/32 ID (43" LG)
28	0G4451	REF	BRACKET STEPPER MOTOR COOLANT
29	055934N	2	CLAMP VINYL 1.31 X .281 Z
30	0F9504	1	GROMMET 5/8"X 1 1/8"X 5/16"
31	0G0568	1	ASSY FAN BEARING SUPPORT
32	0G3433	1	BRACKET FAN ALT ADAPTER 1.6L
33	0E2507	1	PROBE COOLANT LEVEL 3/8NPTF
	0H1827	1	PROBE COOLANT LEVEL 3/8-18NPTF (USE WITH I/N 40, P/N 0H1851)
34	0A2628	1	PULLEY - FAN 95 DIA
35	029333A	10	TIE WRAP UL 7.4" X .19" BLK (NOT SHOWN)
(1) 36	042907	4	SCREW HHC M8-1.25 X 16 G8.8
37	027482	4	WASHER SHAKEPROOF EXT 5/16 STL
38	022129	4	WASHER LOCK M8-5/16
39	039253	4	SCREW HHC M8-1.25 X 20 G8.8
(2) 40	0H1851	1	ASSY PCB LCL SENSOR (USE WITH I/N 33, P/N 0H1827 ONLY)

(1) APPLY LOCTITE 242 TO I/N 36 BEFORE THREADING INTO I/N 31.

(2) USE WITH R-200 CONTROL PANEL ONLY.

GROUP C

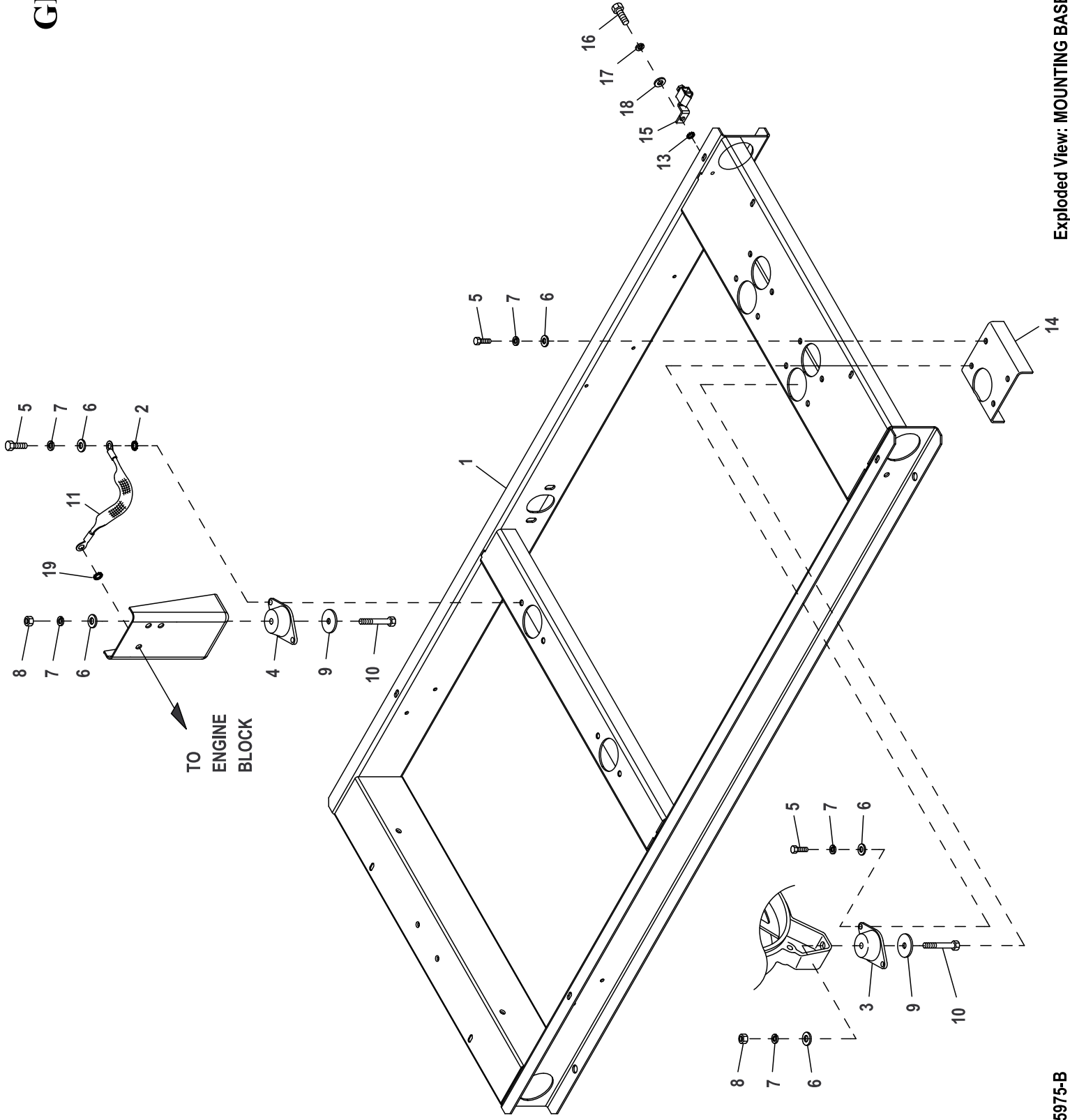

Exploded View: MOUNTING BASE 1.6L
Drawing No.: 0G3531

Page 1 of 2

Revision: H-5975-B
Date: 2/5/10

EXPLODED VIEW: MOUNTING BASE 1.6L**DRAWING #: 0G3531****GROUP C****APPLICABLE TO:**

ITEM	PART#	QTY.	DESCRIPTION
1	0G3343	1	MOUNTING BASE 1.6L 2007 C1
2	027482	1	WASHER SHAKEPROOF EXT 5/16 STL
3	070936	2	DAMPENER VIBRATION
4	070936C	2	VIB. ISO. 70-75 DURO
5	039253	12	SCREW HHC M8-1.25 X 20 G8.8
6	022145	16	WASHER FLAT 5/16 ZINC
7	022129	16	WASHER LOCK M8-5/16
8	045771	4	NUT HEX M8-1.25 G8 YEL CHR
9	071956	4	WASHER FLAT M8
10	051730	4	SCREW HHC M8-1.25 X 60 G8.8
11	021991	1	EARTH STRAP
13	026850	1	WASHER SHAKEPROOF EXT 1/4 STL
14	0G3461	2	ALTERNATOR SUPPORT BLOCK OFF
15	055414	1	LUG SLDLSS #2-#8 X 17/64 CU
16	047411	1	SCREW HHC M6-1.0 X 16 G8.8
17	022097	1	WASHER LOCK M6-1/4
18	022473	5	WASHER FLAT 1/4-M6 ZINC
19	025507	1	WASHER LOCK EXT 7/16 STL

GROUP C

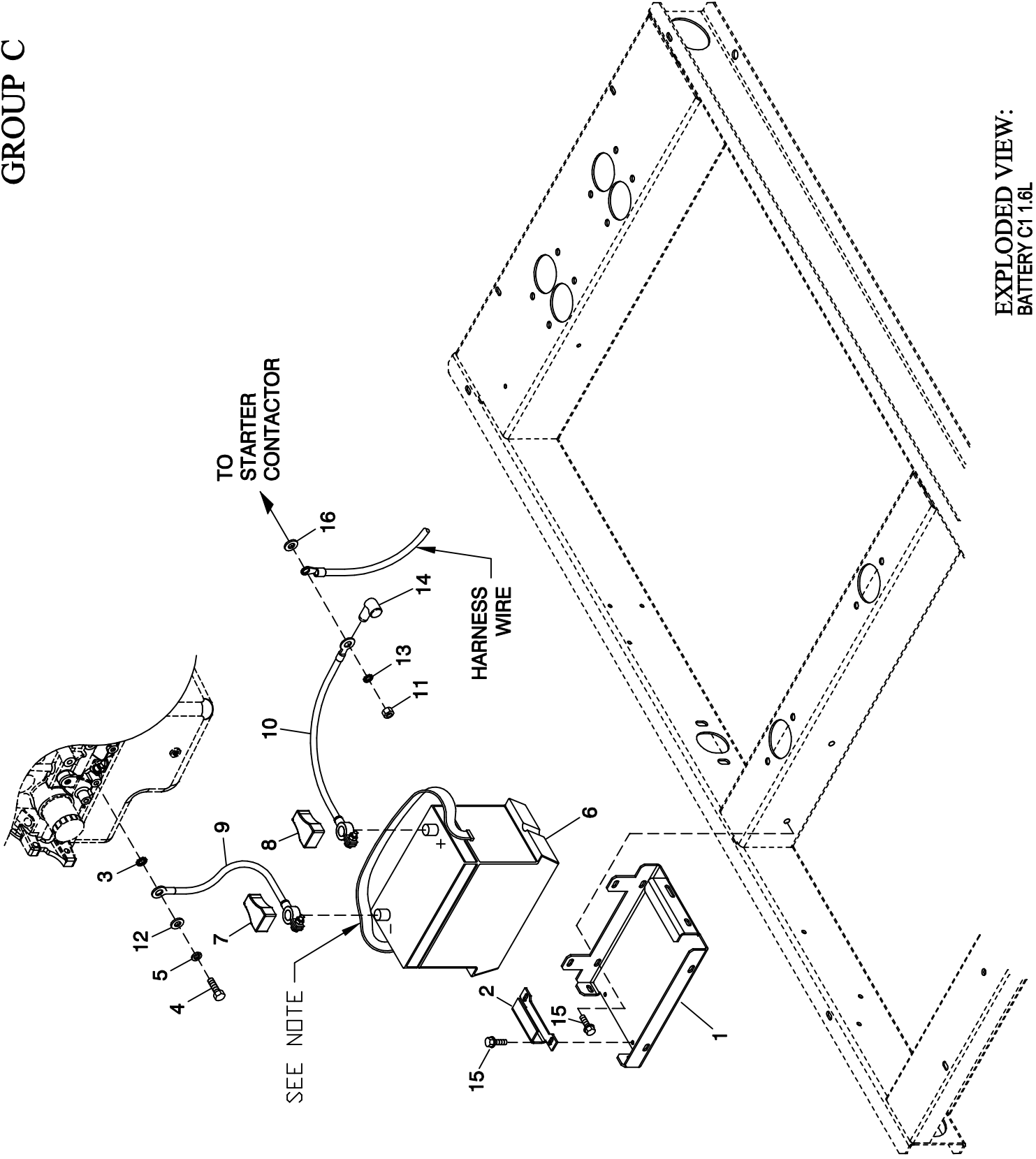

EXPLODED VIEW: BATTERY C1 1.6L**DRAWING #: 0G4067****GROUP C**

APPLICABLE TO:

ITEM	PART #	QTY.	DESCRIPTION
1	0F3408C	1	BATTERY TRAY, C1 & C2
2	0F3411	1	STRAP BATTERY RETAINMENT
3	025507	1	WASHER SHAKEPROOF EXT 7/16 STL
4	059980	1	SCREW HHC M10-1.5 X 25 G10.9
5	046526	1	WASHER LOCK M10
6	077483	REF	BATTERY 12VDC 75-AH 26
7	050331A	REF	BATTERY POST COVER RED +
8	050331	REF	BATTERY POST COVER BLK -
9	038805J	1	CABLE BATTERY BLACK #1 X 30.00
10	038804M	1	CABLE BATTERY RED #1 X 21.00
11	045771	REF	NUT HEX M8-1.25 G8 YEL CHR
12	022131	1	WASHER FLAT 3/8-M10 ZINC
13	027482	1	WASHER SHAKEPROOF EXT 5/16 STL
14	0F3976	1	BOOT CONTACTOR CABLES
15	0C2454	4	SCREW THF M6-1 X 16 N WA Z/JS
16	022145	REF	WASHER FLAT 5/16-M8 ZINC

NOTE: WHEN INSTALLING BATTERY, TUCK BATTERY'S LIFTING STRAP ALONG THE LEFT SIDE OF BATTERY (SIDE OPPOSITE RADIATOR) BEFORE CONNECTING THE BATTERY CABLES.

GROUP D

		TORQUE POUND-FEET (KPM)	
IN	QTY		
20	7	45 (6)	
28	4	45 (6)	

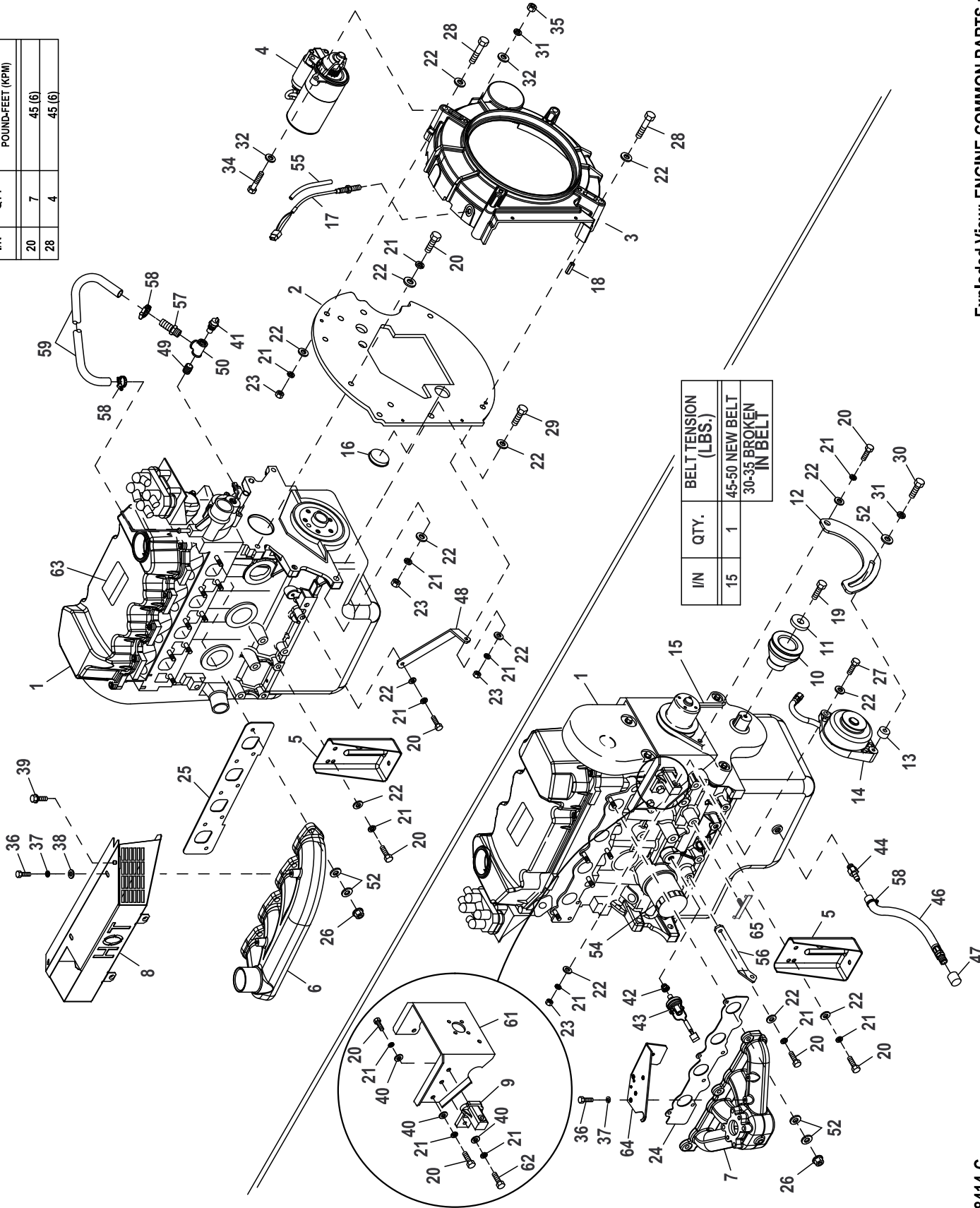

		BELT TENSION (LBS.)	
IN	QTY.	45-50 NEW BELT	30-35 BROKEN IN BELT
15	1		

EXPLODED VIEW: ENGINE COMMON PARTS 1.6L

DRAWING #: 0H7219

GROUP D

APPLICABLE TO:

ITEM	PART#	QTY.	DESCRIPTION
1	0H1734	REF	ENGINE GENERAC 1.6L G11 CERT
2	0G0834A	1	ENGINE PLATE 1.6L 6MM (TO BE USED WITH PLATE SPACER P/N 0G2070A.)
3	0G0820A	REF	HOUSING BLOWER LG PILOT
4	0G7461	1	STARTER MOTOR 12V
5	0G0839	2	ENGINE MOUNTING FOOT STAMPING
6	0G0781	1	EXHAUST MANIFOLD 1.6L MACHINED
7	0G0722	1	INTAKE MANIFOLD MACHINED 1.6L
8	0G4059	1	SHIELD 1.6L EXHAUST HEAT
9	0G4604	1	DC ALTERNATOR ADAPTER MACHINED
10	0G3424	1	PULLEY CRANKSHAFT MACHINED
11	0G0786	1	WASHER PULLEY
12	0G4605	1	BRACKET TENSIONER DC ALT
13	0F9617A	1	SPACER ALTERNATOR
14	0A1354B	1	DC ALTERNATR HAN-KOK
15	0G0823	1	V-BELT 3/8 X 30.6
16	0G3900	1	CAP, 1.5" HOLE SHALLOW
17	0D2244M	1	ASSY MAGPICKUP (3/8-24 MALE)
18	036710	2	PIN SPRING 1/4 X 3/4
19	0C5479	1	SCREW HHC M12-1.5 X 40 G10.9
20	059980	13	SCREW HHC M10-1.5 X 25 G10.9
21	046526	22	WASHER LOCK M10
22	022131	18	WASHER FLAT 3/8-M10 ZINC
23	0G3922	9	NUT HEX M10-1.5 CLASS 10 ZINC
24	0G0464	1	GASKET INTAKE MANIFOLD 1.6L
25	0G0465	1	GASKET EXHAUST MANIFOLD 1.6L
26	052858	14	NUT TOP LOCK FL M8-1.25
27	051735	1	SCREW HHC M10-1.5 X 70 G8.8
28	0G3920	4	SCREW HHC M10-1.5 X 110 G10.9
29	0A7387	4	SCREW HHC M10-1.5 X 40 G10.9
30	039414	1	SCREW HHC M8-1.25 X 35 G8.8
31	022129	4	WASHER LOCK M8-5/16
32	022145	3	WASHER FLAT 5/16-M8 ZINC
33	029333A	1	TIE WRAP UL 7.4" X .19" BLK
34	057821	3	SCREW HHC M8-1.25 X 40 G8.8
35	045771	3	NUT HEX M8-1.25 G8 CLEAR ZINC
36	022507	4	SCREW HHC 1/4-20 X 1/2 G5
37	022097	4	WASHER LOCK M6-1/4
38	022473	5	WASHER FLAT 1/4-M6 ZINC
39	090388	3	SCREW HHTT M6-1.0 X 12 ZINC
40	0A5768	5	WASHER FLAT M10 HEAVY DUTY
41	0E0502	1	TEMPERATURE SENDER, DELPHI
42	035579	1	BSHG RDCR HEX 1/4 TO 1/8
43	0H7435	1	HARN LOW OIL PRESS SWITCH ASSY
44	0C1852	1	ADAPTER DRAIN OIL
46	069860C	1	HOSE OIL DRAIN ASSY 21"
47	069811	1	CAP HEX 1/4 NPT BRASS
48	0G38580ST03	1	STRUT LH 1.6L ENG ADAPT PLATE
49	025065	1	NIPPLE PIPE 3/8 NPT X 1-1/2
50	027738A	1	PIPE TEE 3/8 NPT
51	0E3257	3	SCREW HWHTF M6-1.0 X 16
52	0A8830	29	WASHER FLAT .34 ID X .75 OD
53	0H6690	1	HARN ENG G1.6L G11 NEXUS (NOT SHOWN)
54	0G02070100	1	OIL FILTER 1.6L
55	077043H	1	CONDUIT FLEX .25"ID (6" LG)
56	0G38620ST03	1	STRUT RH 1.6L ENG ADAPT PLATE
57	055596	1	BARBED STR 3/8 NPT X 3/8
58	0C7649	3	CLAMP HOSE .38- .87
59	0H2250	1	HOSE COOLANT 3/8 ID 20R3 (11" LG)
61	0G3433	REF	BRACKET FAN ALT ADAPTER 1.6L
62	049541	1	SCREW HHC M10-1.5 X 35 G8.8
63	0G7311	REF	DECAL EMISSION CTRL INFO 1.6L
64	0G4451	1	BRACKET STEPPER MOTOR COOLANT
65	0F4001E	1	ANCHOR HARNESS

GROUP E

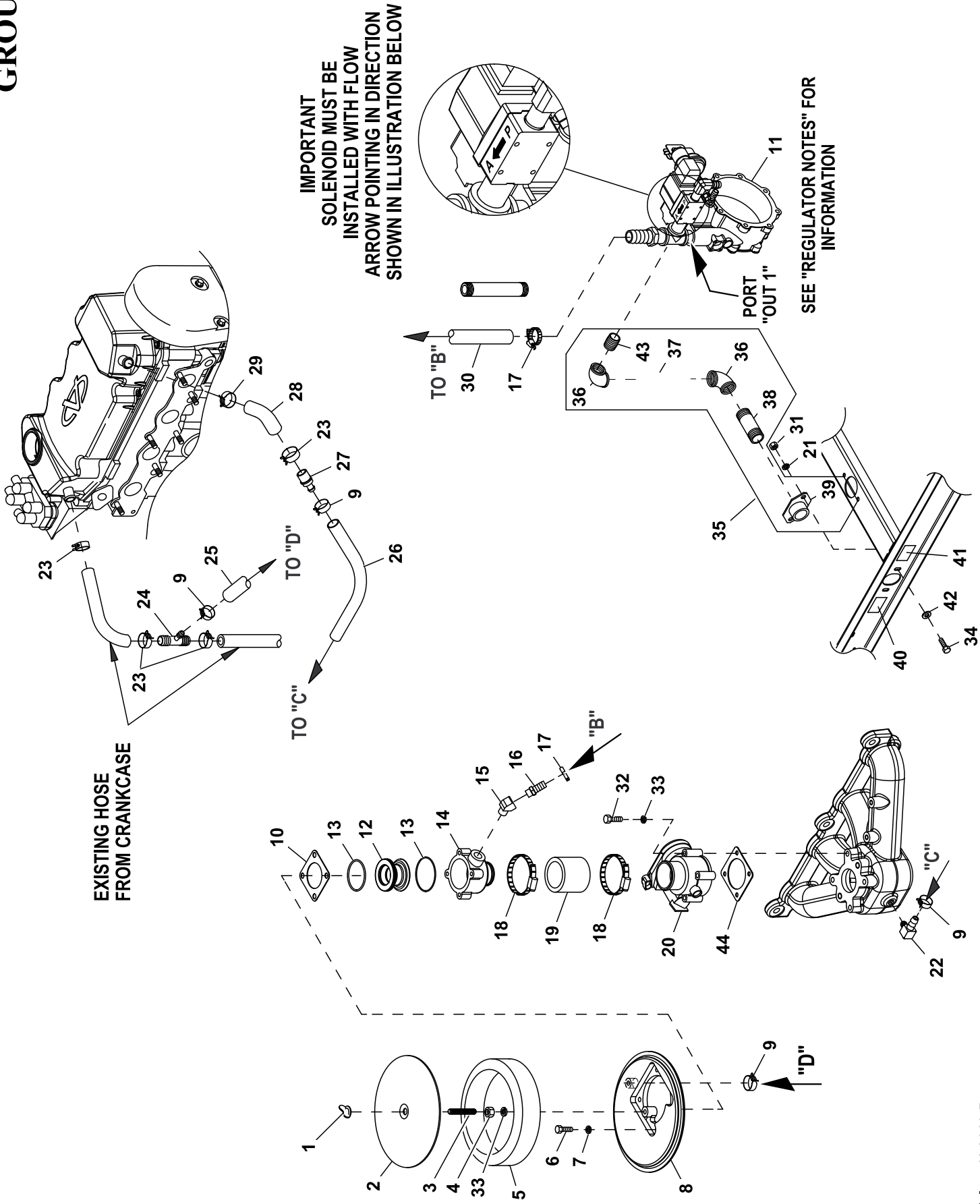

EXPLODED VIEW: FUELSYS NG/LPV 1.6L CPL

DRAWING #: 0H6671

GROUP E

APPLICABLE TO:

ITEM	PART#	QTY.	DESCRIPTION
1	037561	1	NUT WING 1/4-20 NYLK
2	0A5547	1	COVER AIR CLEANER
3	062522	1	STUD TH 1/4-20 X 3 G2 ZNC FULL
4	022127	1	NUT HEX 1/4-20 STEEL
5	059402	1	FILTER ELEMENT
6	091526	4	SCREW PPHM M5-0.8 X 12 ZNC
7	049226	4	WASHER LOCK M5
8	0E0519A	1	ADAPTER, CARBURETOR W/PVC CONN
9	048031J	4	CLAMP HOSE BAND .63
10	0E6586	1	GASKET BOSCH 32 & 40
11	0G1397E	1	FUEL REG. REWORK 1.6L
12	0F7790	1	VENTURI THROTTLE 21MM
13	0E7121	2	O-RING 47.625 ID X 2.38 WIDTH
14	0G4573C	1	MIXER ACTUATOR 32MM MACHINED
15	0E8286	1	STREET EL 45D 1/2 NPT BRASS
16	047527	1	BARBED STR 1/2 NPT X 3/4
17	057823	2	CLAMP HOSE #10 .56-1.06
18	035685	2	CLAMP HOSE #28 1.32-2.25
19	057753B	1	HOSE 1.5 ID X 2 LG 20R4
20	0E4395	1	ACTUATOR BOSCH 32 GOVERNOR
21	022129	2	WASHER LOCK M8-5/16
22	0A6344	1	BARBED EL 90 1/8 NPT X 3/8
23	048031L	4	CLAMP HOSE BAND 1.0"
24	0G1985	1	HOSE BARB REDUCR TEE 3/4"-3/8"
25	047290	1	HOSE 3/8 ID SINGLE BRAID (11.5" LG)
26	047290	1	HOSE 3/8 ID SINGLE BRAID (12" LG)
27	0F3994	1	PCV VALVE 2.5L FORD
28	0G3178	1	HOSE BREATHER 1.6L
29	048031P	1	CLAMP HOSE BAND .88"
30	057147	1	HOSE 3/4 ID LPG & NG (16"LG)
31	045771	2	NUT HEX M8-1.25 G8 YEL CHR
32	051767	4	SCREW HHC M6-1.0 X 45 C8.8 FTH
33	022097	5	WASHER LOCK M6-1/4
34	039253	2	SCREW HHC M8-1.25 X 20 G8.8
35	0G9348	1	ASSY REG INLET NPT FITTINGS
(1)36	026812	2	ELBOW 90D 3/4 NPT
(1)37	076691	1	NIPPLE PIPE 3/4NPTX4.5 BLK IRN
(1)38	026490	1	NIPPLE PIPE 3/4NPT X 2
(1)39	075580	1	FLANGE FUEL INLET
40	0D1509	1	DECAL INLET PRESSURE
41	075436	1	DECAL FUEL INLET
42	022145	2	WASHER FLAT 5/16 ZINC
(1)43	026915	1	NIPPLE CLOSE 3/4 X 1.375
44	0E6586A	1	GASKET BOSCH 32

(1) INCLUDED IN ITEM 35 (ASSY REG INLET NPT FITTINGS)

GROUP F

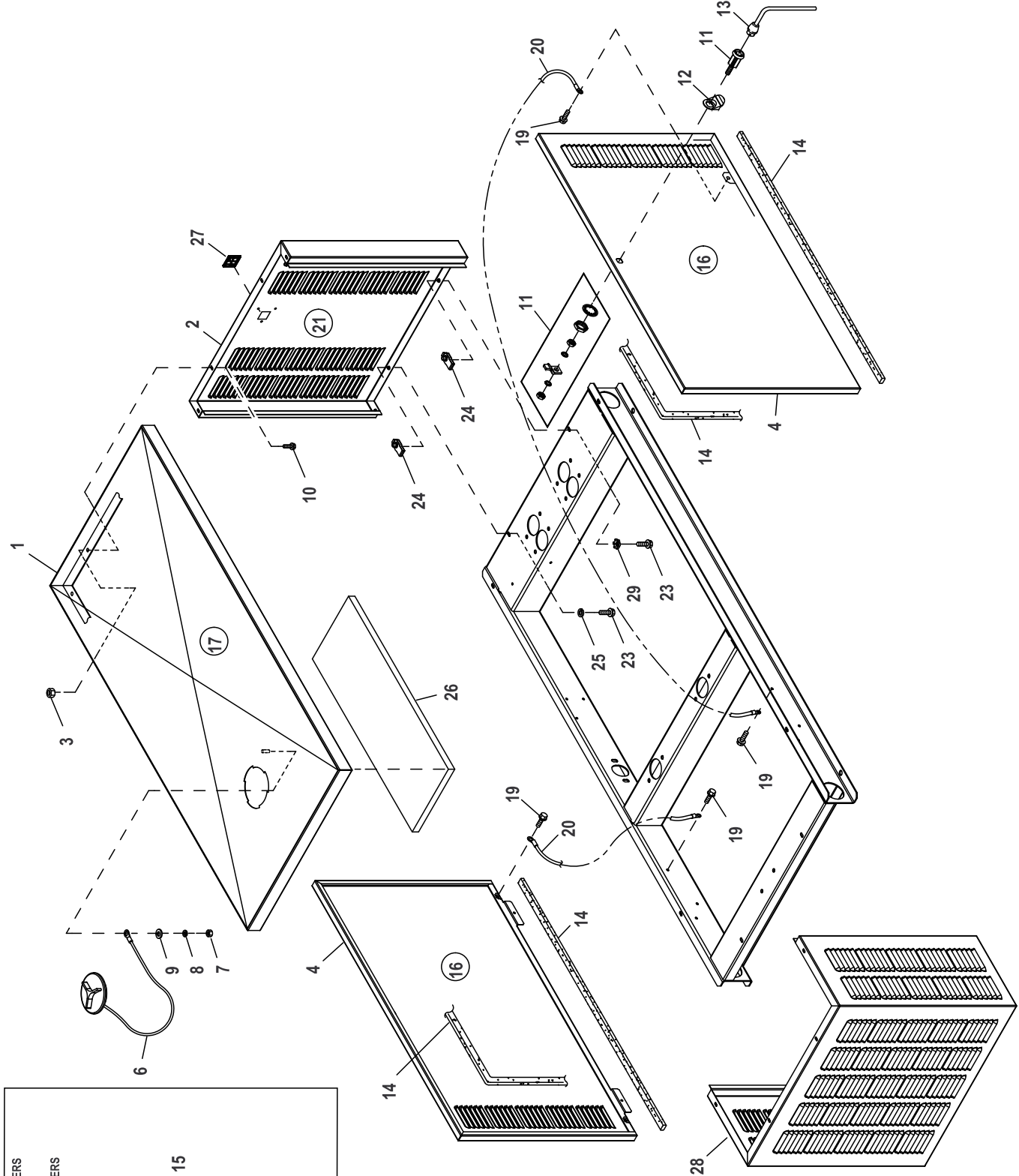

○ INSULATION AND DOME WASHERS LOCATED ON THE NEAR SIDE.
 ○ INSULATION AND DOME WASHERS LOCATED ON THE FAR SIDE.

15
 TYPICAL MOUNTING OF ROOF ACOUSTIC INSULATION.

EXPLODED VIEW: EV ENCLOSURE C1 CPL

DRAWING #: 0G3534

GROUP F

ITEM	PART#	QTY.	DESCRIPTION
(2) 1	0G33370AL0R	1	ROOF 1.6L C1
(2) 2	0J14640AL0R	1	REAR INTAKE WRAP C1
(1) 3	077992	10	NUT HEX LOCK M6-1.0 SS NY INS
(2) 4	0J14630AL0R	2	DOOR LEFT/RIGHT SIDE C1
6	0F4487A	1	ASSY ACCESS COVER
7	022127	1	NUT HEX 1/4-20 STEEL
8	022097	1	WASHER LOCK M6-1/4
9	022473	1	WASHER FLAT 1/4-M6 ZINC
(1)10	0C2454	8	SCREW THF M6-1 X 16 N WA Z/JS
11	0F5048D	2	WISE-ACTION LATCH, SLOTTED CIR
12	0F5049	2	TAB PULL
13	0F8869D	1	KEY VISE-ACTION LATCH,SLOT CIR
14	089961	1	FOAM STRIP 3/4"WIDE X 3/16"THK (294"LG)
15	078115	8	WASHER SELF LOCKING DOME
16	0H7518	2	INSULATION SIDE DOOR C1
17	0H7518A	1	INSULATION ROOF C1
(1)19	0E3257	6	SCREW HWHTF M6-1.0 X 16
20	0912970090	2	ASSY WIRE 14AWG GRN/YEL (32.25"LG)
21	0H7518B	1	INSULATION REAR C1
23	0C8566	10	SCREW HHFC M6-1.0 X 20 G8.8
24	0H0412	10	NUT SPRINGCLIP M6-1.0
25	022097	8	WASHER LOCK M6-1/4
(3) 26	0H7529	1	FOIL ALUMINUM WITH ADHESIVE
27	0H1208A	1	RF COVER PLATE-PLASTIC-BISQUE
	0H1208B	1	RF COVER PLATE-PLASTIC-GREY
(2) 28	0G33350AL0R	1	FRONT DISCHARGE WRAP 1.6L C1
(1)29	0A1658	2	WASHER LOCK SPECIAL 1/4"

(1)ENCLOSURE NOTE: ALL PANELS THAT FASTEN TO THE ROOF MUST BE SECURED USING I/N 10 (THREAD FORMING FASTENER) AND I/N 3 (LOCK NUT) AND TO INCLUDE AT LEAST ONE CONNECTION POINT USING I/N 19 (THREAD FORMING FASTENER) WITH I/N 3 (LOCK NUT) TO EACH PANEL. LOCK NUT IS TO BE INSTALLED AFTER THREAD FORMING FASTENER HAS PENETRATED THROUGH EXTRUSION IN ENCLOSURE PANELS. ALL PANEL TO BASEFRAME CONNECTIONS TO INCLUDE AT LEAST ONE CONNECTION POINT USING I/N 29 (WASHER SPECIAL).

(2) SHEET METAL PARTS LISTED IN THE BOM TABLE ARE REPRESENTING GENERIC PARTS (NO COLOR)

- MANUFACTURING: FOR CORRECT MATERIAL AND COLOR REFER TO AS400 BOM.
- CUSTOMER: WHEN ORDERING REPLACEMENT PARTS ENTER BASE NUMBER (FIRST 6 DIGITS ONLY) IN THE SYSTEM FOR CORRECT MATERIAL AND COLOR (FOR REFERENCE SEE GUIDELINE 0H7169).

(3) USED ON 1.5L / 1.6L UNITS ONLY.1

GROUP F

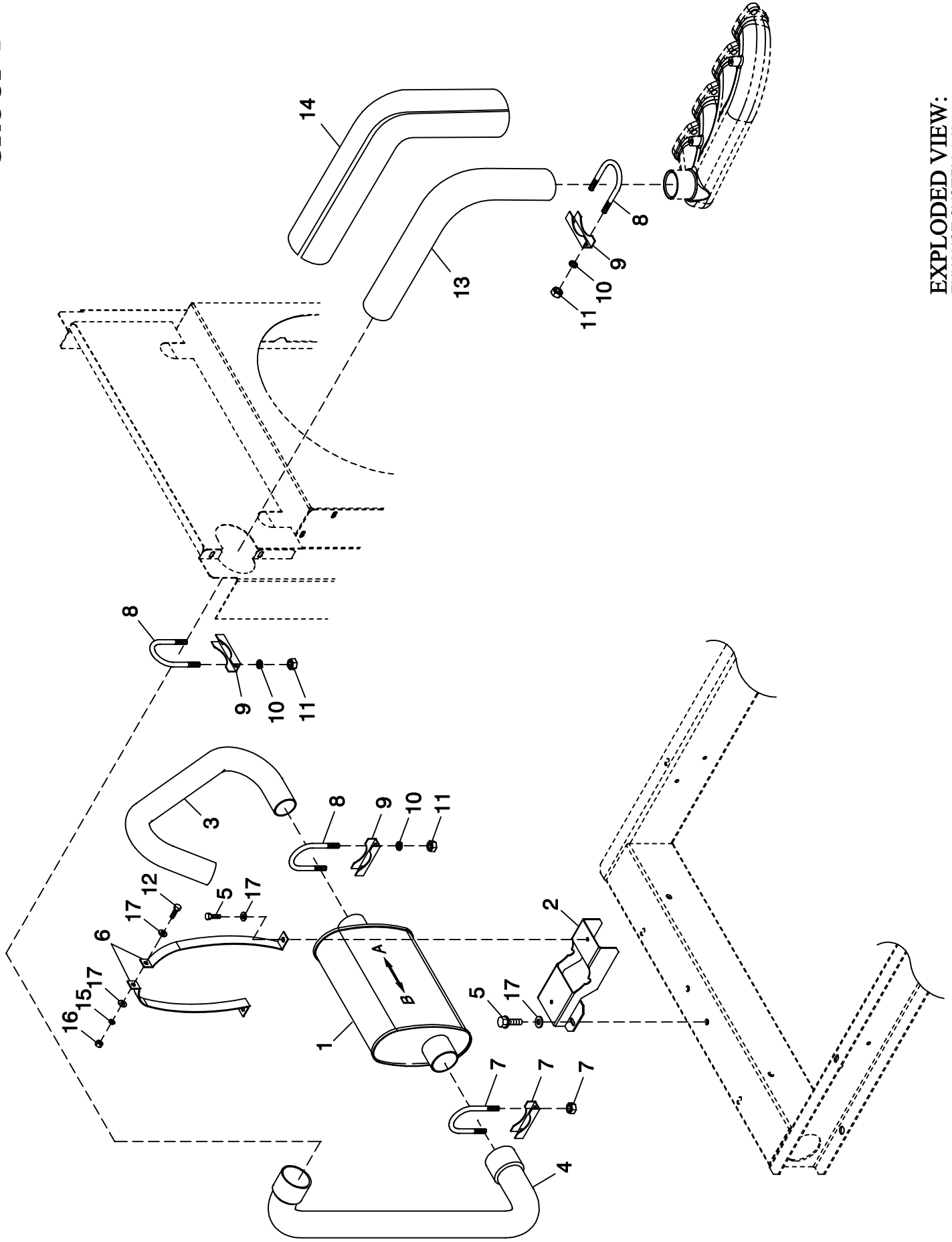

EXPLODED VIEW: EXHAUST SYSTEM 1.6L**DRAWING #: 0G3535****GROUP F**

APPLICABLE TO:

ITEM	PART #	QTY.	DESCRIPTION
1	0F7366	1	MUFFLER C1
2	0F7647	1	MUFFLER SADDLE
3	0F8095	1	PIPE EXHAUST OUTLET
4	0G3576	1	EXHAUST PIPE LOWER 1.6L
5	0E3257	4	SCREW HWHTF M6-1.0 X 16
6	0F7644	2	MUFFLER STRAP
7	0C6119	1	BOLT U 5/16-18 X 2-1/4
8	036434	3	BOLT U 5/16-18 X 2.09
9	036449	3	SADDLE 2 INCH
10	022129	6	WASHER LOCK M8-5/16
11	022259	6	NUT HEX 5/16-18 STEEL
12	038750	1	SCREW HHC M6-1.0 X 30 G8.8
13	0G3575	1	EXHAUST PIPE UPPER 1.6L SS
14	0F3794A	1	EXHAUST BLANKET 500MM LONG
15	022097	1	WASHER LOCK M6-1/4
16	049813	1	NUT HEX M6 X 1.0 G8 YEL CHR
17	022473	6	WASHER FLAT 1/4-M6 ZINC

GROUP G

NOTES:

- 1) MINIMUM RECOMMENDED CONCRETE PAD SIZE: 1041 (41.0") WIDE X 1892 (74.5") LONG. REFERENCE INSTALLATION GUIDE SUPPLIED WITH UNIT FOR CONCRETE PAD GUIDELINES.
- 2) ALLOW SUFFICIENT ROOM ON ALL SIDES OF THE GENERATOR FOR MAINTENANCE AND SERVICING. THIS UNIT MUST BE INSTALLED IN ACCORDANCE WITH CURRENT APPLICABLE NFPA 37 AND NFPA 70 STANDARDS AS WELL AS ANY OTHER FEDERAL, STATE AND LOCAL CODES FOR MINIMUM DISTANCES FROM OTHER STRUCTURES.
- 3) CIRCUIT BREAKER INFORMATION:
SEE SPECIFICATION SHEET WITHIN OWNERS MANUAL
- 4) INSIDE STUB-UP AREA FOR AC LOAD LEAD CONDUIT CONNECTION, NEUTRAL CONNECTION, BATTERY CHARGER 120 VOLT AC (.5 AMP MAX.) CONNECTION, ACCESS TO TRANSFER SWITCH CONTROL WIRES, AND TRANSFER SWITCH CONNECTION (IF SO EQUIPPED). REMOVE FRONT COVER FOR ACCESS.
- 4A) FIELD CUT HOLE IS ONLY REQUIRED FOR MOUNTING OF GENERATOR ON AN EXISTING PAD.
- 5) REFERENCE OWNERS MANUAL FOR LIFTING WARNINGS.
- 6) REMOVE LIFT-OFF ENCLOSURE TO ACCESS EXHAUST MUFFLER.

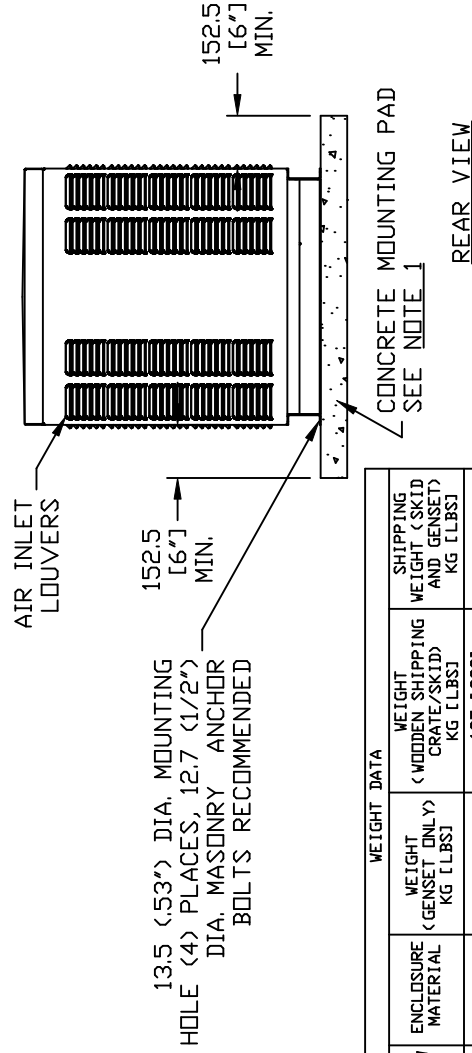

ENGINE/KW	WEIGHT DATA				
	ENCLOSURE MATERIAL	WEIGHT (GENSET ONLY) KG [LBS]	WEIGHT (WOODEN SHIPPING CRATE/SKID) KG [LBS]	SHIPPING WEIGHT (SKID AND GENSET) KG [LBS]	
1. 6L/18KW	STEEL	424 [935]	127 [280]	551 [1215]	
	ALUMINUM	383 [845]	127 [280]	510 [1125]	
1. 6L/20KW	STEEL	397 [875]	127 [280]	524 [1155]	
	ALUMINUM	356 [785]	127 [280]	483 [1065]	
1. 6L/25KW	STEEL	397 [875]	127 [280]	524 [1155]	
	ALUMINUM	356 [785]	127 [280]	483 [1065]	
1. 6L/30KW	STEEL	424 [935]	127 [280]	551 [1215]	
	ALUMINUM	383 [845]	127 [280]	510 [1125]	

EXPLODED VIEW:
INSTALLATION DRAWING C1 CPL
DRAWING #: 0G5116

GROUP G

SERVICE ITEM ACCESSIBILITY CHART

SERVICE ITEM	ACCESS
OIL FILL CAP	EITHER DOOR
OIL DIP STICK	THRU RIGHT DOOR
OIL FILTER	THRU RIGHT DOOR
OIL DRAIN HOSE	THRU RIGHT DOOR
RADIATOR DRAIN HOSE	THRU RIGHT DOOR
AIR CLEANER ELEMENT	THRU RIGHT DOOR
SPARK PLUGS	THRU RIGHT DOOR
MUFFLERS	SEE NOTE 6
FAN BELT	THRU RIGHT DOOR
BATTERY	THRU RIGHT DOOR

REFERENCE OWNERS MANUAL FOR PERIODIC REPLACEMENT PART LISTINGS

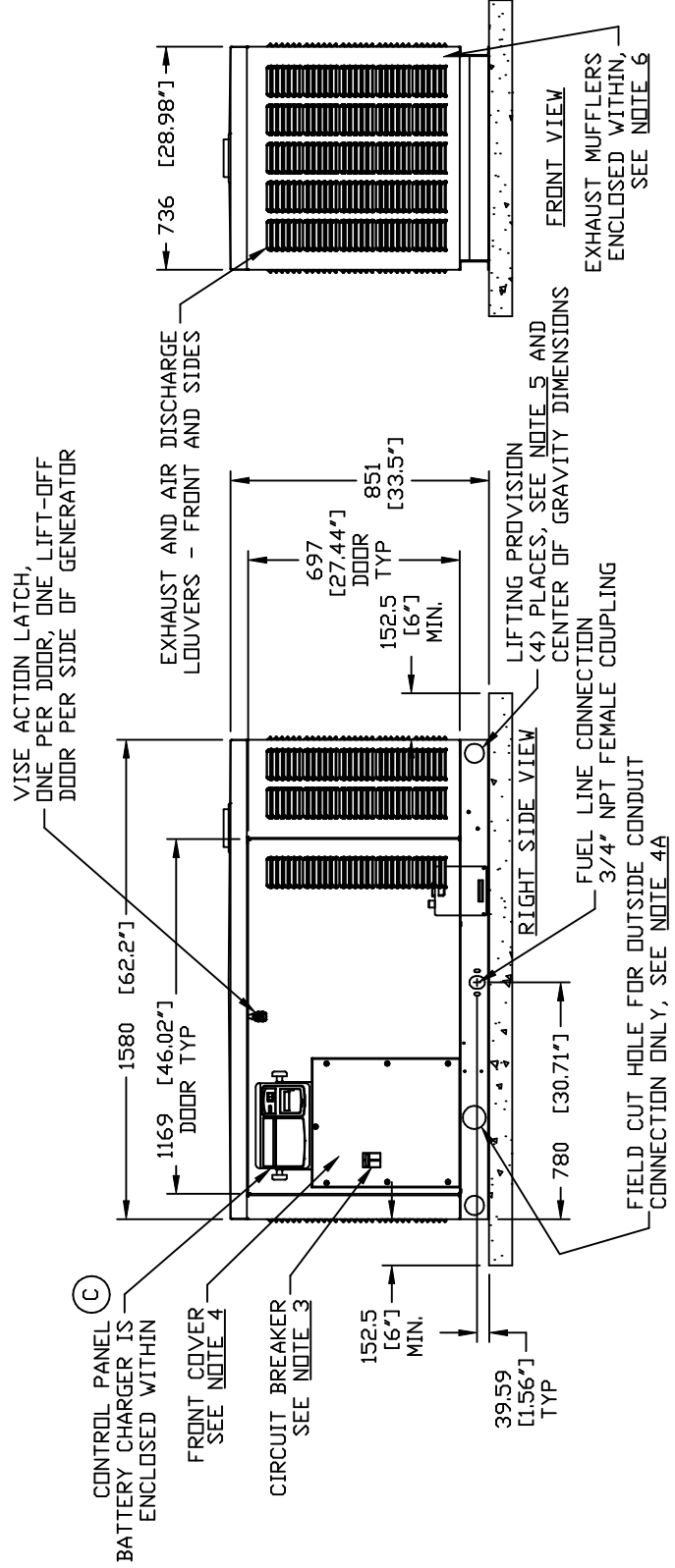
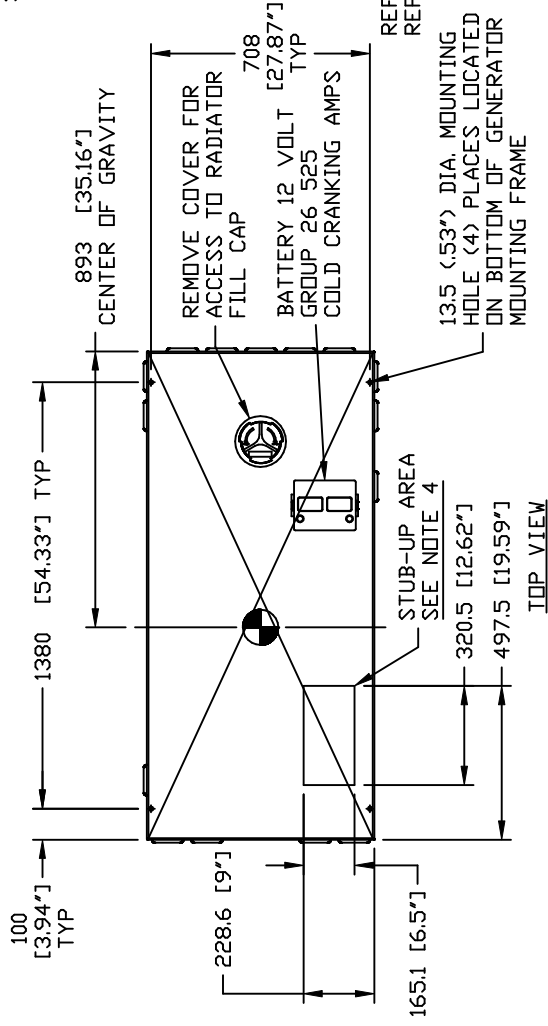

EXPLODED VIEW:
INSTALLATION DRAWING C1 CPL
DRAWING #: 0G5116

OPTION 1 - SINGLE PHASE, CPL CONTROL PANEL

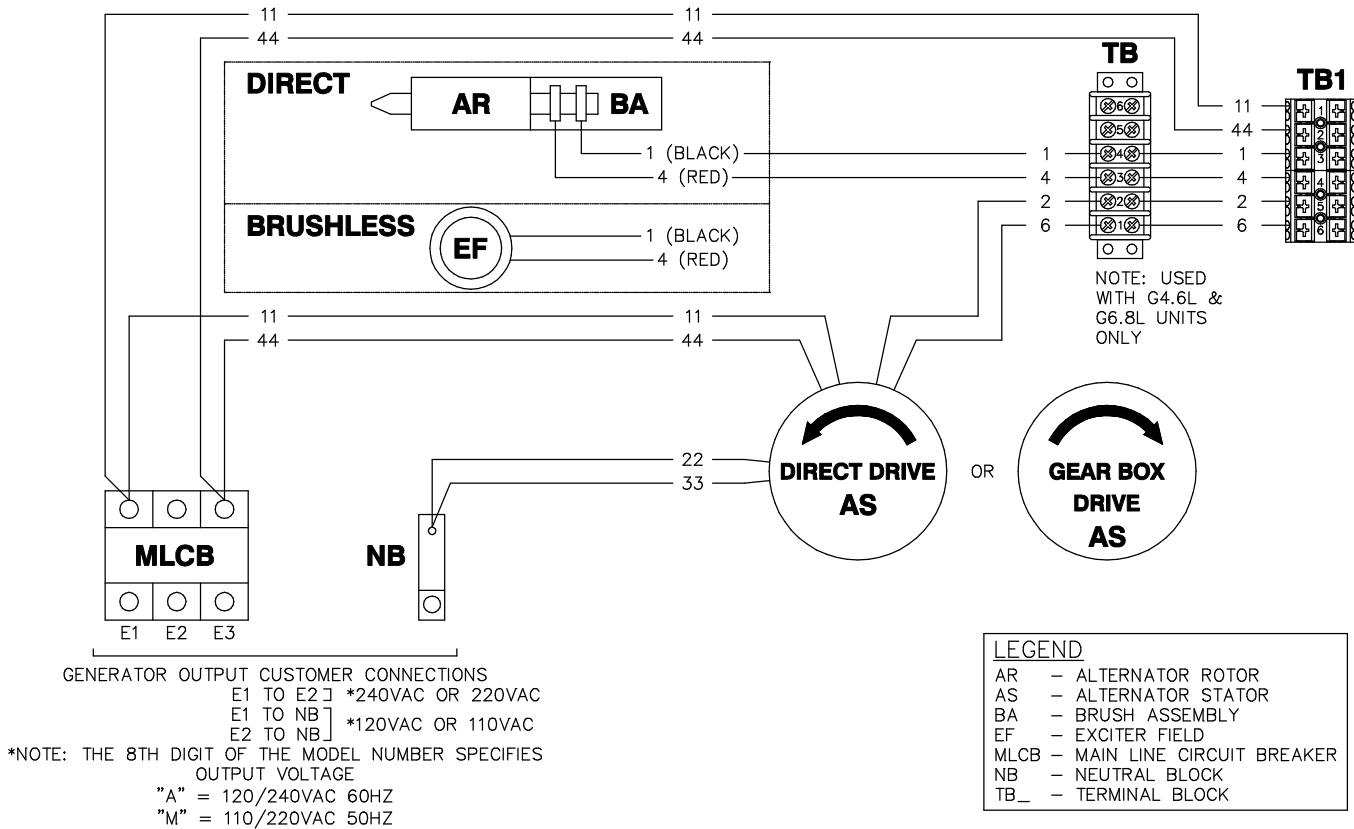

OPTION 2 - THREE PHASE, CPL CONTROL PANEL, 120/208V

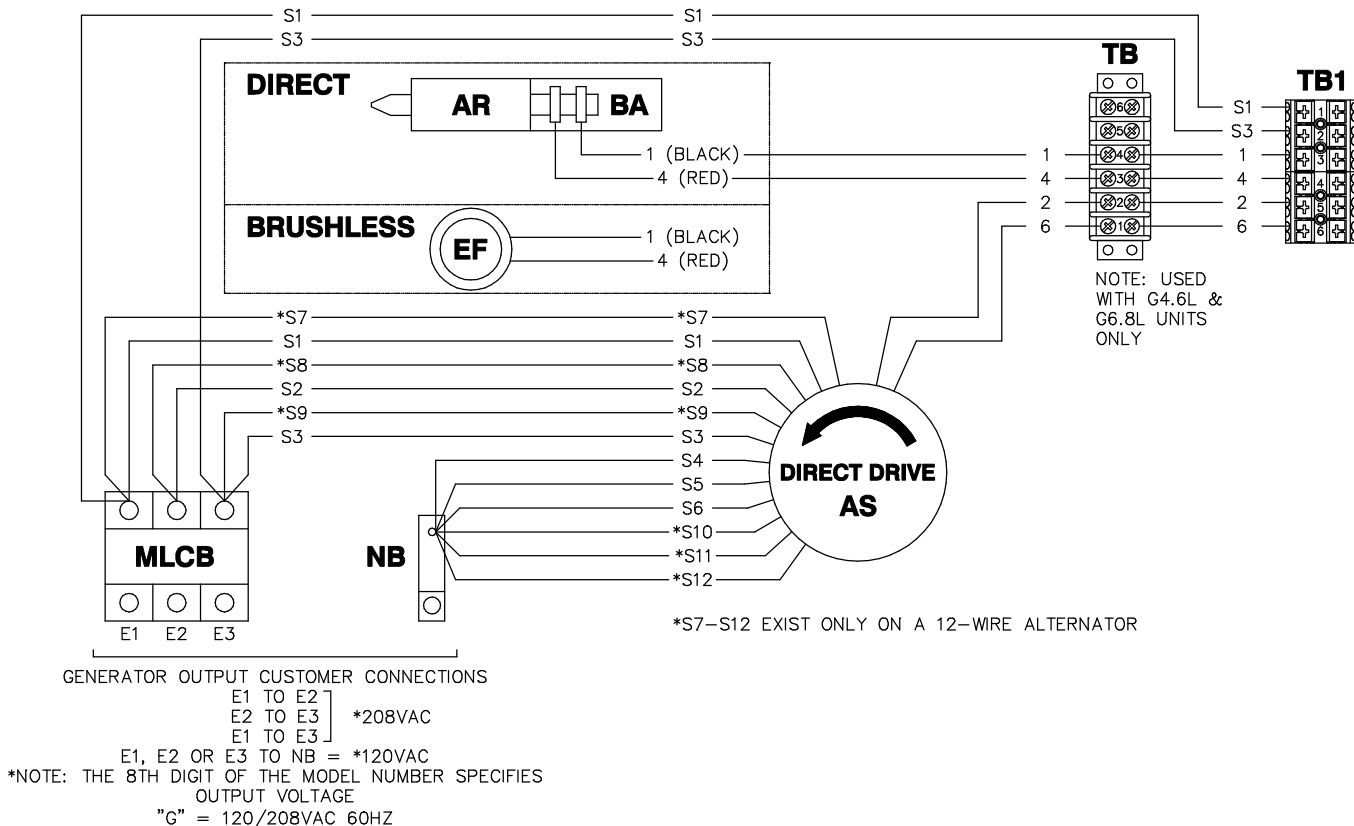

OPTION 3 - THREE PHASE, CPL CONTROL PANEL, 6-WIRE 277/480V

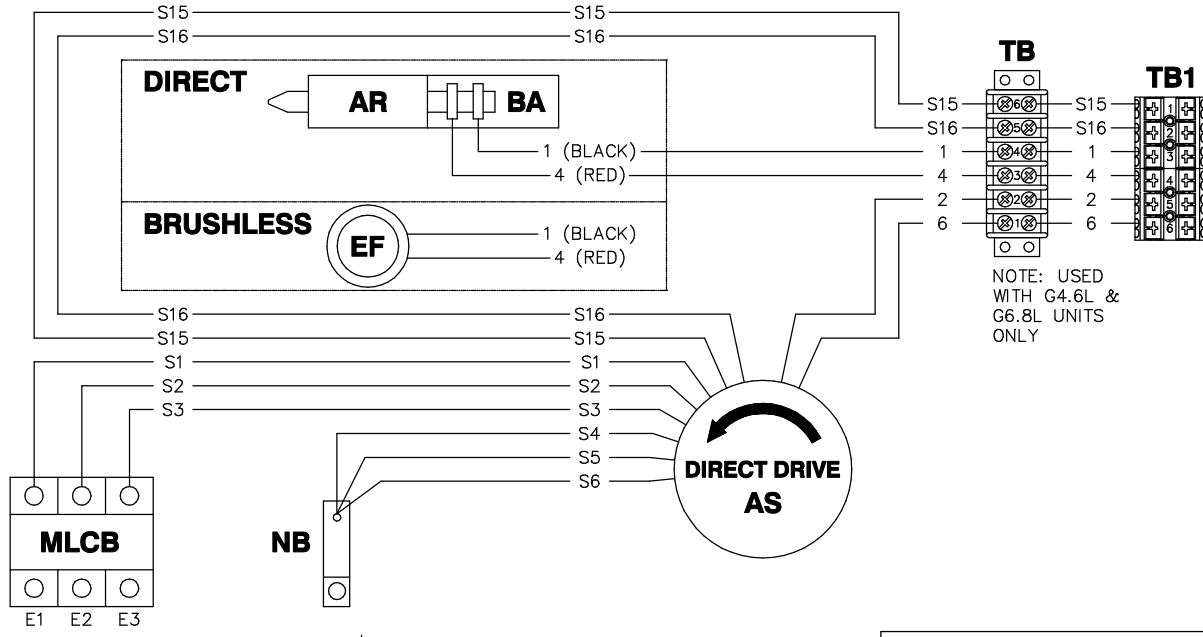

NOTE: USED WITH G4.6L & G6.8L UNITS ONLY

LEGEND	
AR	- ALTERNATOR ROTOR
AS	- ALTERNATOR STATOR
BA	- BRUSH ASSEMBLY
EF	- EXCITER FIELD
MLCB	- MAIN LINE CIRCUIT BREAKER
NB	- NEUTRAL BLOCK
TB_	- TERMINAL BLOCK

GENERATOR OUTPUT CUSTOMER CONNECTIONS

E1 TO E2
E2 TO E3] *480VAC OR *400VAC
E1 TO E3]

E1, E2 OR E3 TO NB = *277VAC OR *231VAC

*NOTE: THE 8TH DIGIT OF THE MODEL NUMBER SPECIFIES OUTPUT VOLTAGE

"K" = 277/480VAC 60HZ

"R" = 231/400VAC 50HZ

OPTION 4 - THREE PHASE DELTA, CPL CONTROL PANEL, 7-WIRE 120/240V

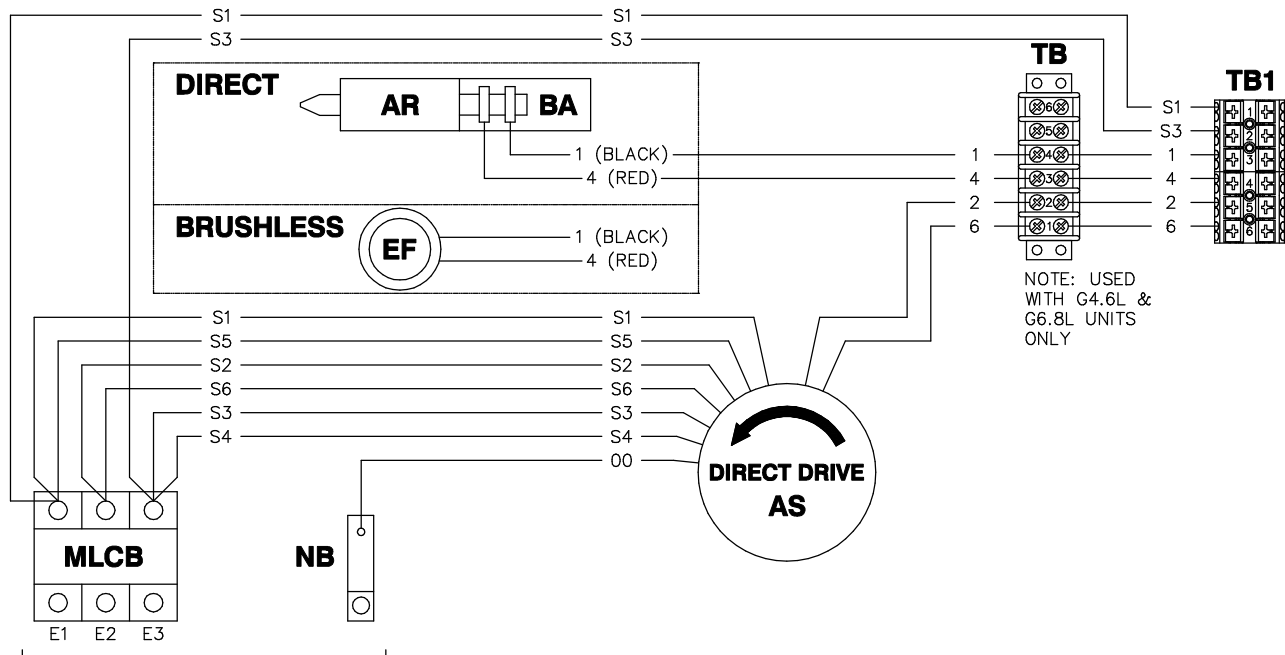

NOTE: USED WITH G4.6L & G6.8L UNITS ONLY

GENERATOR OUTPUT CUSTOMER CONNECTIONS

E1 TO E2
E2 TO E3] *240VAC
E1 TO E3]

E1 OR E3 TO NB = *120VAC

*NOTE: THE 8TH DIGIT OF THE MODEL NUMBER SPECIFIES OUTPUT VOLTAGE

"J" = 120/240VAC 60HZ

OPTION 5 - THREE PHASE, CPL CONTROL PANEL, GEARBOX (REVERSE ROTATION)

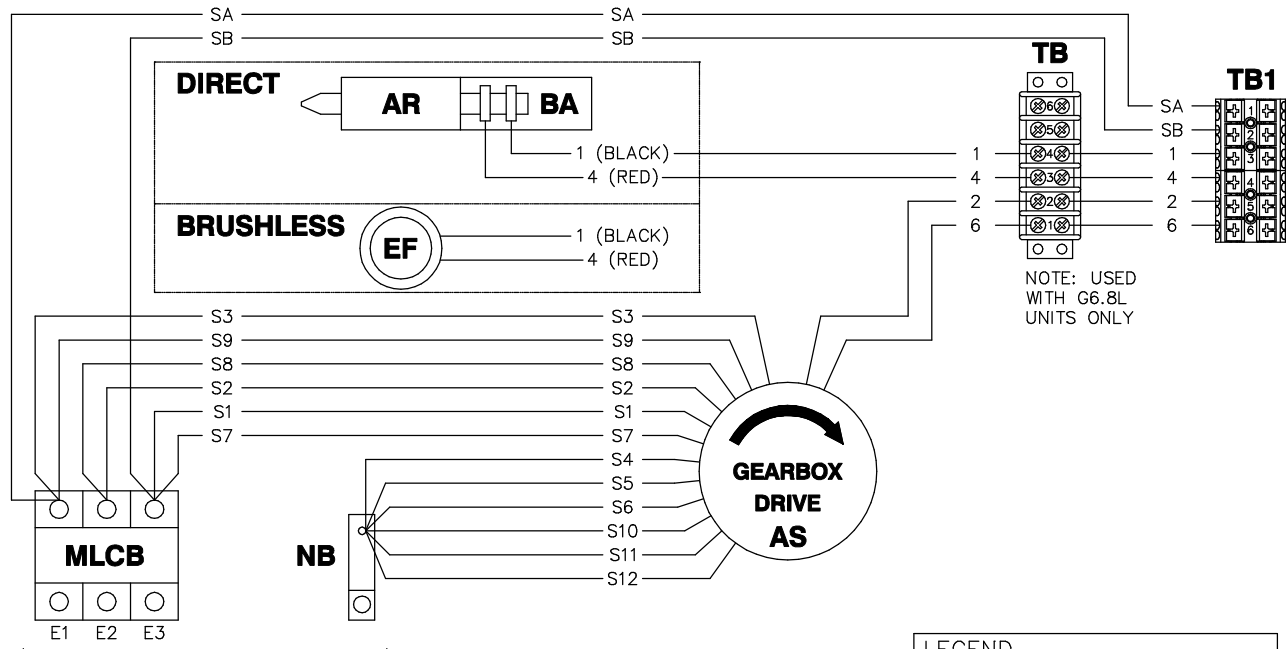

NOTE: USED WITH G6.8L UNITS ONLY

LEGEND	
AR	- ALTERNATOR ROTOR
AS	- ALTERNATOR STATOR
BA	- BRUSH ASSEMBLY
EF	- EXCITER FIELD
MLCB	- MAIN LINE CIRCUIT BREAKER
NB	- NEUTRAL BLOCK
TB_	- TERMINAL BLOCK

GENERATOR OUTPUT CUSTOMER CONNECTIONS

E1 TO E2] *208VAC
E2 TO E3]
E1 TO E3]

E1, E2 OR E3 TO NB = *120VAC

*NOTE: THE 8TH DIGIT OF THE MODEL NUMBER SPECIFIES OUTPUT VOLTAGE

"G" = 120/208VAC 60HZ

OPTION 6 - THREE PHASE, CPL CONTROL PANEL, GEARBOX (REVERSE ROTATION)

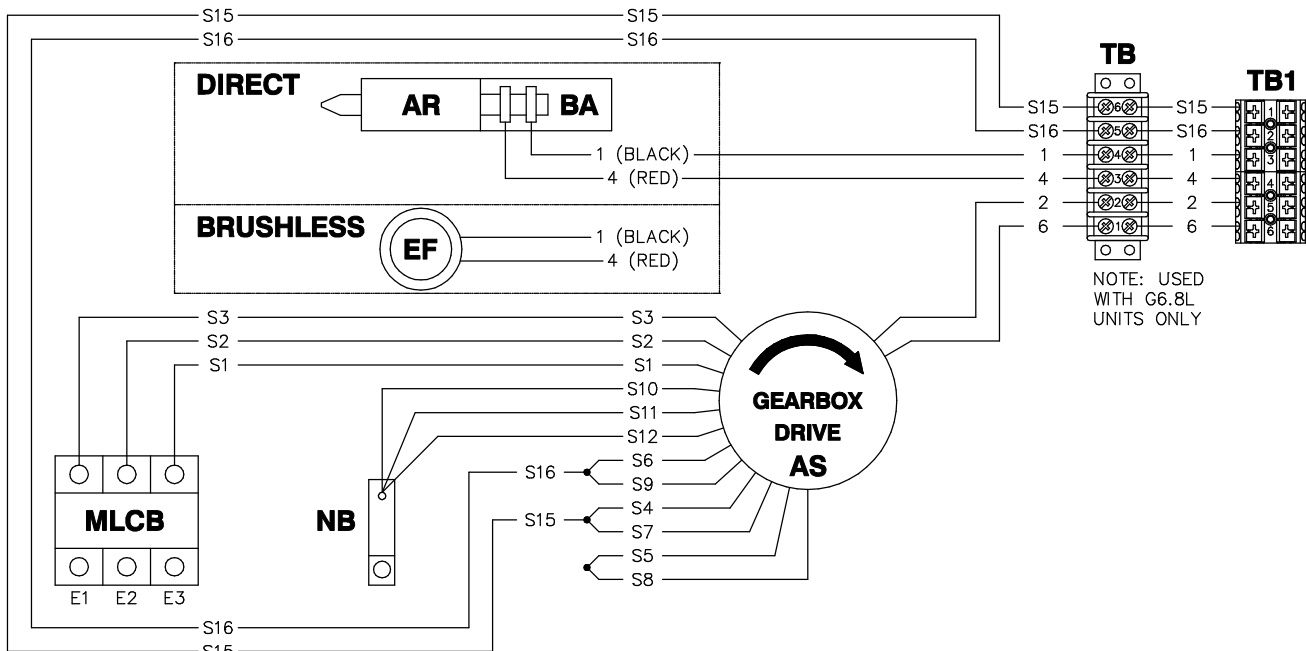

NOTE: USED WITH G6.8L UNITS ONLY

GENERATOR OUTPUT CUSTOMER CONNECTIONS

E1 TO E2] *480VAC
E2 TO E3]
E1 TO E3]

E1, E2 OR E3 TO NB = *277VAC

*NOTE: THE 8TH DIGIT OF THE MODEL NUMBER SPECIFIES OUTPUT VOLTAGE

"K" = 277/480VAC 60HZ

OPTION 7 - THREE PHASE SERIES DELTA, CPL CONTROL PANEL, GEARBOX (REVERSE ROTATION)

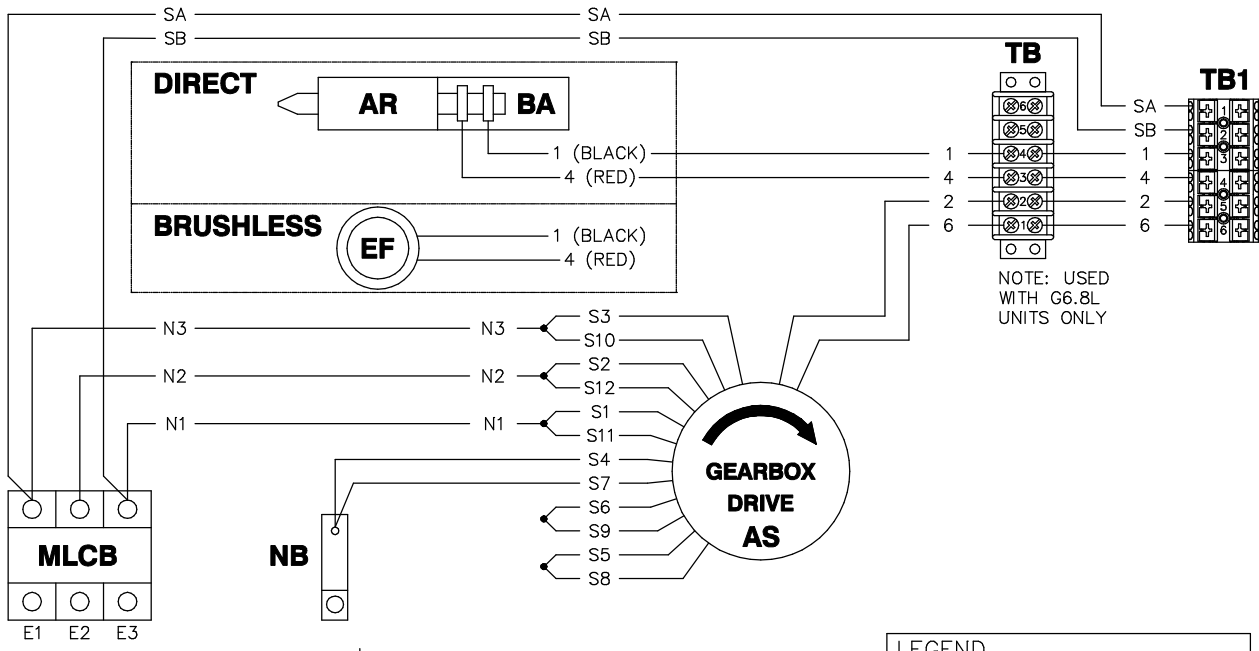

NOTE: USED WITH G6.8L UNITS ONLY

GENERATOR OUTPUT CUSTOMER CONNECTIONS
 E1 TO E2] *240VAC
 E2 TO E3]
 E1 TO E3]
 E1-N OR E2-N OR E3-N = *120VAC
 *NOTE: THE 8TH DIGIT OF THE MODEL NUMBER SPECIFIES OUTPUT VOLTAGE
 "J" = 120/240VAC 60HZ

LEGEND	
AR	- ALTERNATOR ROTOR
AS	- ALTERNATOR STATOR
BA	- BRUSH ASSEMBLY
EF	- EXCITER FIELD
MLCB	- MAIN LINE CIRCUIT BREAKER
NB	- NEUTRAL BLOCK
TB_	- TERMINAL BLOCK

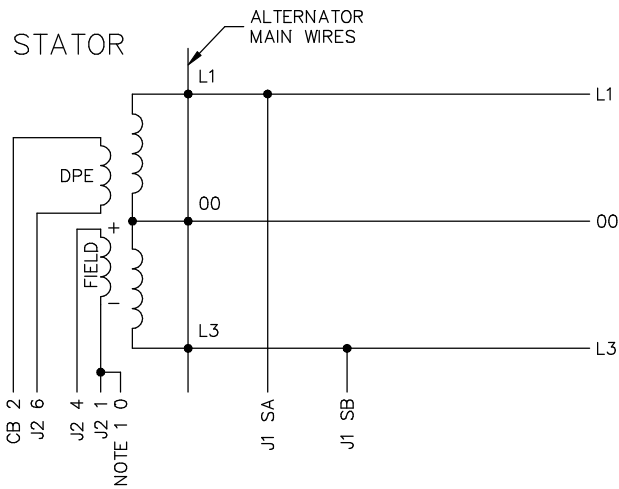

ALTERNATOR CONNECTIONS FOR 1Ø UNITS

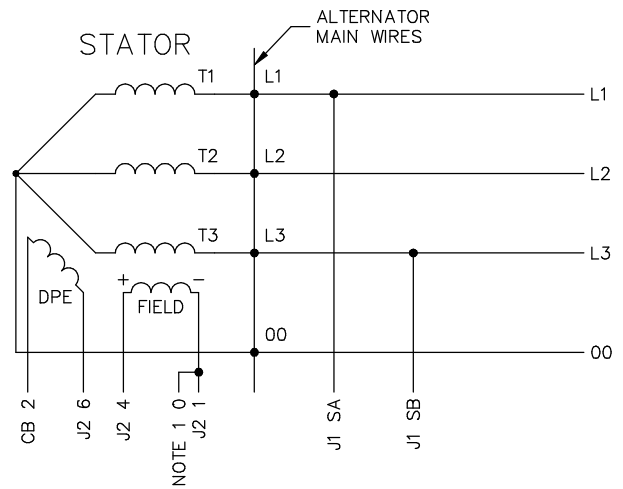

ALTERNATOR CONNECTIONS FOR 3Ø UNITS

ALTERNATOR CONNECTION BOX

GENERATOR SET

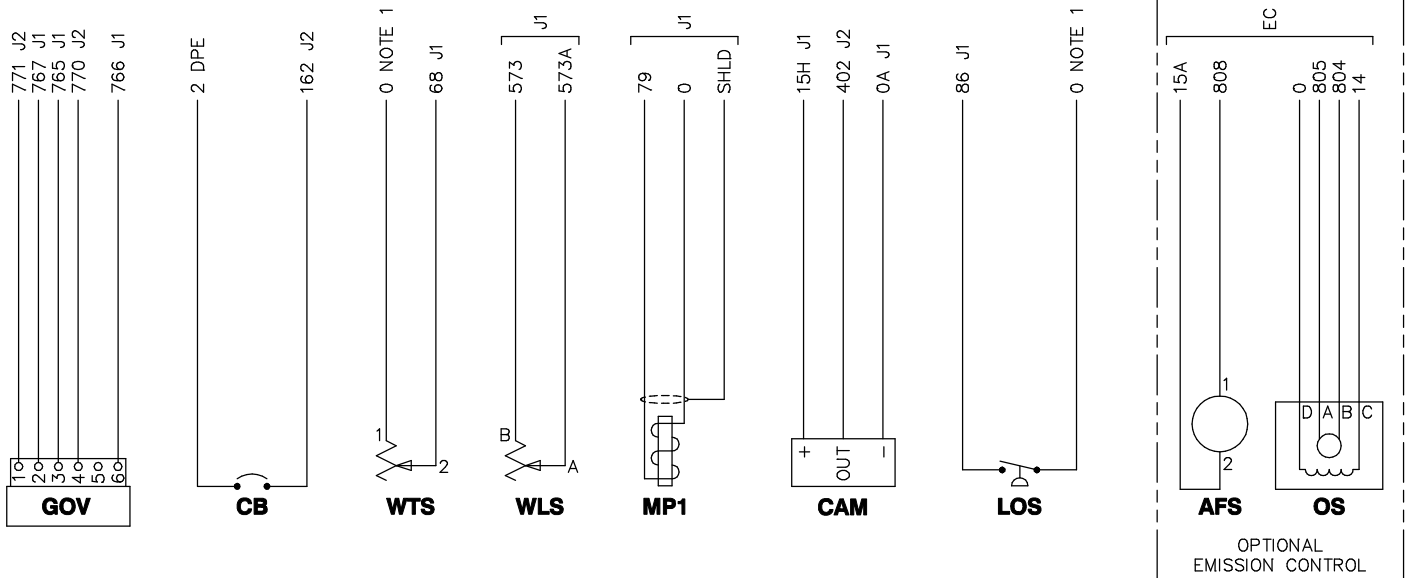

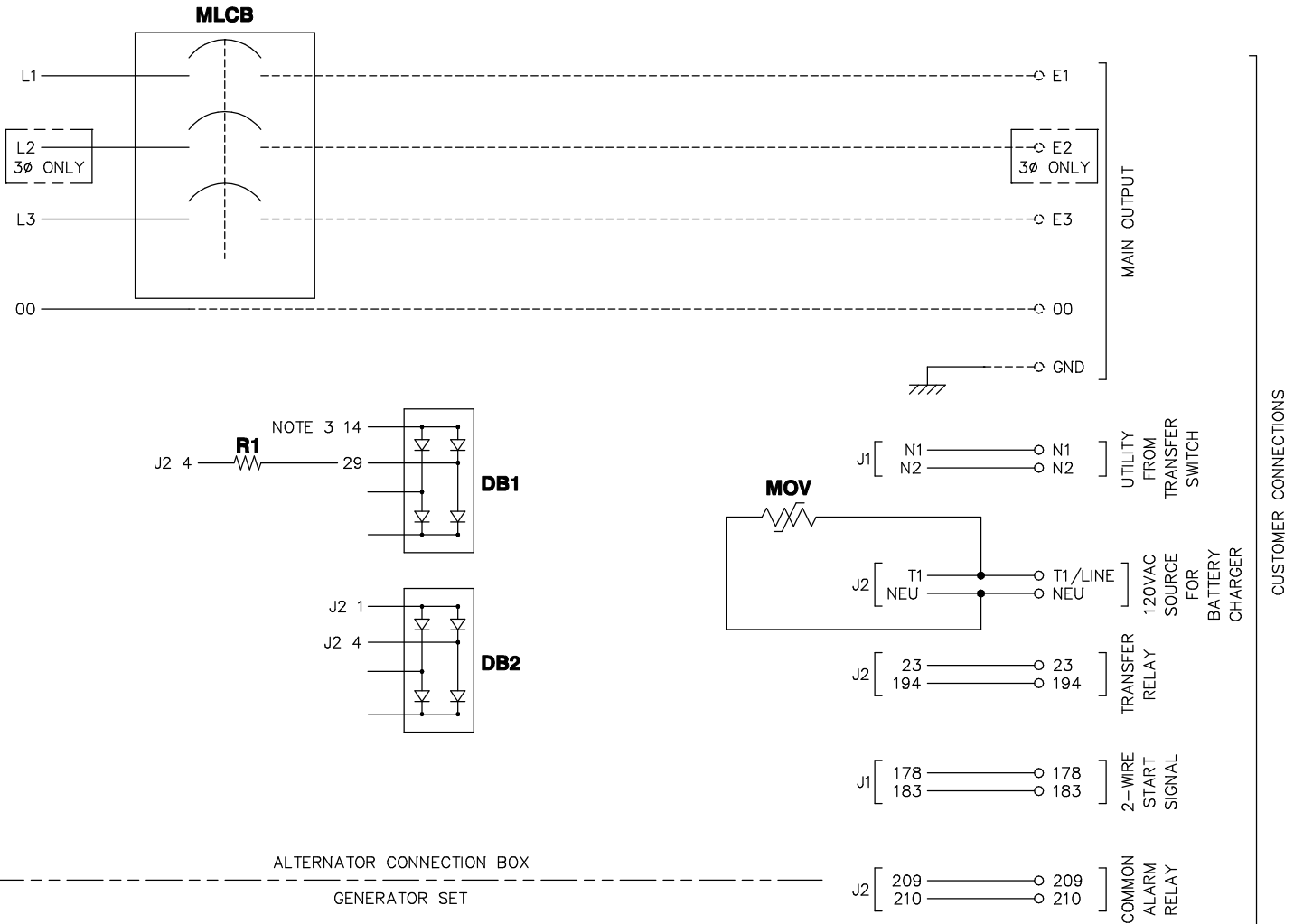

NOTE:
FOR FIELD WIRING TO CUSTOMER CONNECTIONS
(TERMINAL BLOCKS)
MAXIMUM WIRE SIZE: #12 AWG

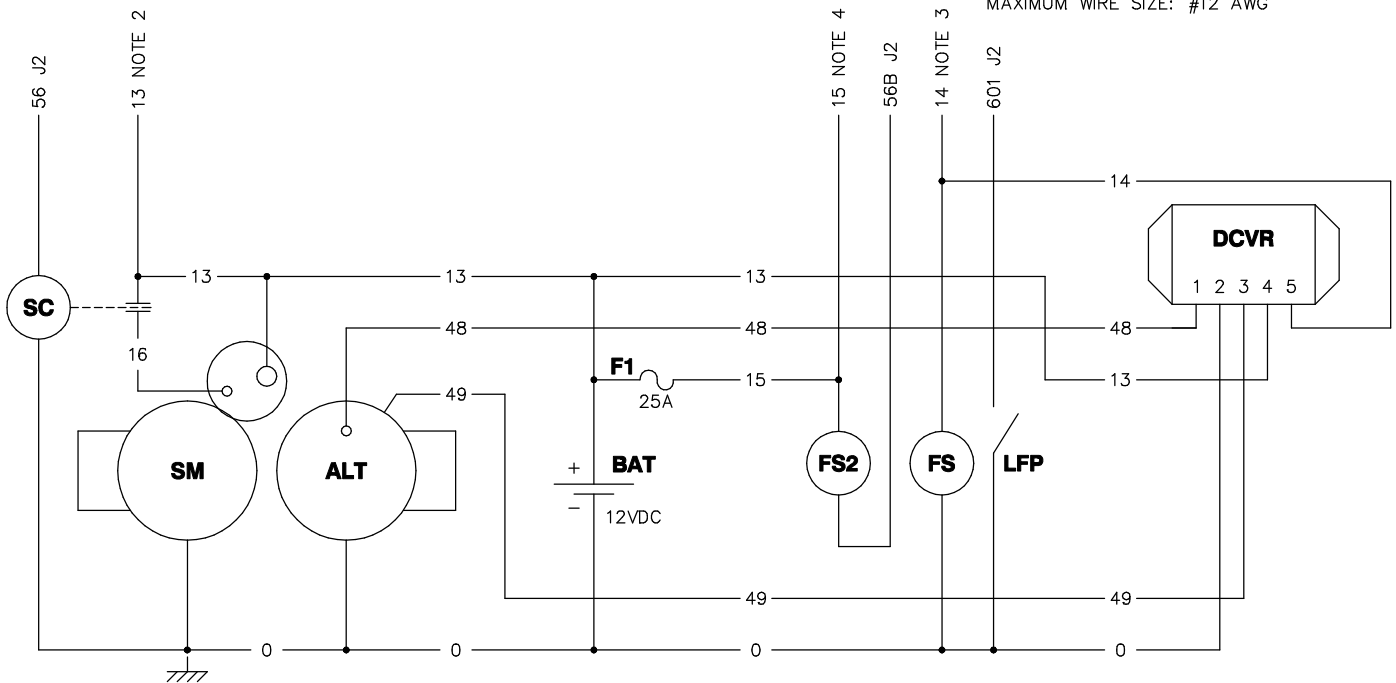

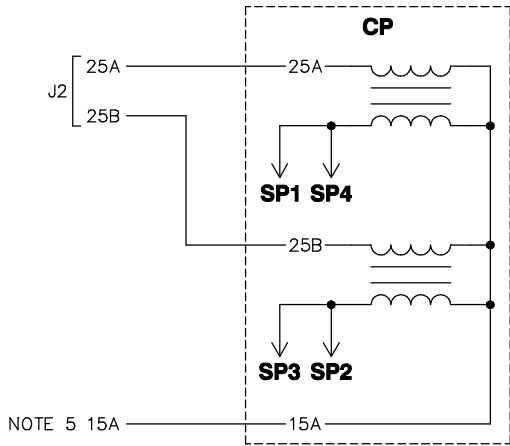

NOTES:

- 1) WIRE #0 IS CHASSIS GROUND (BATTERY-) UNLESS NOTED OTHERWISE.
- 2) WIRE #13 IS UNFUSED +12VDC (BATTERY+).
- 3) WIRE #14 IS FUSED +12VDC WHEN GENERATOR IS CRANKING OR RUNNING.
- 4) WIRE #15 IS FUSED +12VDC FOR GENERAL USE.
- 5) WIRE #15A IS FUSED +12VDC FOR THE AIR/FUEL SOLENOID OPTION AND FOR THE IGNITION COILS.

BWR CONNECTOR

PIN	WIRE	TO	FUNCTION
1	820	J1-12	+5V POWER FOR BASIC REMOTE
2	817	J1-4	REMOTE DISPLAY SYSTEM READY
3	818	J1-5	REMOTE DISPLAY ALARM
4	819	J1-17	REMOTE DISPLAY MAINTENANCE
5	0	GND	NOTE 1

EC CONNECTOR

PIN	WIRE	TO	FUNCTION
1	0	GND	NOTE 1
2	14	J2-8	NOTE 3
3	15A	J2-23	NOTE 5
4	808	J2-2	AIR/FUEL RATIO SOLENOID DRIVER
5	805	J1-35	OXYGEN SENSOR RETURN
6	804	J1-34	OXYGEN SENSOR +

ENGINE CONTROL MODULE CONNECTIONS

J1

PIN	WIRE	TO	FUNCTION
1	178	CUST CON	REMOTE START RETURN
4	817	BWR-2	REMOTE DISPLAY SYSTEM READY
5	818	BWR-3	REMOTE DISPLAY ALARM
6	15	F1	NOTE 4
7	15	F1	NOTE 4
8	0	GND	NOTE 1
9	0	GND	NOTE 1
10	0	MP1-2	FLYWHEEL SENSOR -
11	0A	CAM-3	HALL-EFFECT CAMSHAFT SENSOR -
12	820	BWR-1	+5V POWER FOR BASIC REMOTE
13	SA	MLCB	OUTPUT VOLTAGE SENSING A
14	183	CUST CON	REMOTE START
16	SHLD	MP1-1	FLYWHEEL SENSOR DRAIN
17	819	BWR-4	REMOTE DISPLAY MAINTENANCE
18	767	GOV-2	THROTTLE POSITION FEEDBACK RETURN
19	765	GOV-3	THROTTLE POSITION FEEDBACK SOURCE
20	766	GOV-6	THROTTLE POSITION FEEDBACK SIGNAL
21	68	WTS-2	COOLANT TEMP SIGNAL
22	0	GND	NOTE 1
23	79	MP1-3	FLYWHEEL SENSOR +
24	SB	MLCB	OUTPUT VOLTAGE SENSING B
25	N1	CUST CON	UTILITY VOLTAGE SENSING 1
26	N2	CUST CON	UTILITY VOLTAGE SENSING 2
30	15H	CAM-1	HALL-EFFECT CAMSHAFT SENSOR +
31	573A	WLS-A	COOLANT LEVEL SIGNAL RETURN
32	573	WLS-B	COOLANT LEVEL SIGNAL
33	86	LOS-NC	LOW OIL PRESSURE SIGNAL
34	804	EC-6	OXYGEN SENSOR +
35	805	EC-5	OXYGEN SENSOR RETURN

J2

PIN	WIRE	TO	FUNCTION
1	770	GOV-4	THROTTLE DRIVE HI
2	808	EC-4	AIR/FUEL RATIO SOLENOID DRIVER
3	56B	FS2	STARTING FUEL SOLENOID CONTROL
4	25A	CP-1	IGNITION COIL DRIVE 1 AND 4
5	25B	CP-2	IGNITION COIL DRIVE 2 AND 3
8	14	DB1/FS/EC-2	NOTE 3
9	771	GOV-1	THROTTLE DRIVE LO
10	402	CAM-2	HALL-EFFECT CAMSHAFT SENSOR SIGNAL
11	209	CAR	COMMON ALARM RELAY
12	23	CUST CON	TRANSFER RELAY COIL CONTROL
13	194	CUST CON	TRANSFER RELAY COIL +
14	601	LFP	LOW FUEL PRESSURE
15	210	CAR	COMMON ALARM RELAY
16	6	DPE	EXCITER RETURN
17	162	CB	EXCITER OUTPUT (BREAKER PROTECTED)
18	4	FIELD	FIELD (BRUSH) +
19	1	FIELD	FIELD (BRUSH) -
20	T1	CUST CON	120VAC SOURCE FOR BATTERY CHARGER
21	NEU	CUST CON	120VAC RETURN FOR BATTERY CHARGER
22	56	SC	STARTER CONTACTOR DRIVER
23	15A	EC-3/CP-3	NOTE 5

LEGEND

00 - NEUTRAL	DCVR - DC VOLTAGE REGULATOR	MOV - METAL OXIDE VARISTOR
AFS - AIR/FUEL SOLENOID	DPE - EXCITER	MP1 - MAGNETIC PICKUP
ALT - DC CHARGE ALTERNATOR	EC - EMISSIONS CONNECTOR	OS - OXYGEN SENDER
BAT - BATTERY	F1 - FUSE INLINE	R1 - RESISTOR
BWR - BASIC WIRELESS RECEPTACLE	FS_ - FUEL SOLENOID	SC - STARTER CONTACTOR
CAM - CAMSHAFT SENSOR	GOV - ELECTRONIC GOVERNOR ACTUATOR	SHLD - SHIELD
CAR - COMMON ALARM RELAY	J_ - ENGINE CONTROL MODULE CONNECTOR	SM - STARTER MOTOR
CB - CIRCUIT BREAKER	LFP - LOW FUEL PRESSURE SWITCH	SP_ - SPARK PLUG
CP - COIL PACK	LOS - LOW OIL PRESSURE SWITCH	WLS - COOLANT LEVEL SENDER
DB_ - DIODE BRIDGE	MLCB - MAIN LINE CIRCUIT BREAKER	WTS - COOLANT TEMPERATURE SENDER

LEGEND

AFS - AIR/FUEL SOLENOID	HVR - HIGH VOLTAGE RECEPTACLE 12-PIN
ALT - DC CHARGE ALTERNATOR	J1 - ENGINE CONTROL MODULE 35-PIN CONNECTOR
AS - ALTERNATOR STATOR	J2 - ENGINE CONTROL MODULE 23-PIN CONNECTOR
BA - BRUSH ASSEMBLY	LFP - LOW FUEL PRESSURE SWITCH
BAT - BATTERY	LOS - LOW OIL PRESSURE SWITCH
BWR - BASIC WIRELESS RECEPTACLE	LVP - LOW VOLTAGE PLUG 8-PIN (BULKHEAD)
CAM - CAMSHAFT SENSOR	LVR - LOW VOLTAGE RECEPTACLE 8-PIN
CAR - COMMON ALARM RELAY	MLCB - MAIN LINE CIRCUIT BREAKER
CB - CIRCUIT BREAKER	MOV - METAL OXIDE VARISTOR
CP - COIL PACK	MP1 - MAGNETIC PICKUP
DB - DIODE BRIDGE	NB - NEUTRAL BLOCK
DCVR - DC VOLTAGE REGULATOR	OS - OXYGEN SENDER
EC - EMISSIONS CONNECTOR	R1 - RESISTOR
F1 - FUSE INLINE (25A ATO)	SC - STARTER CONTACTOR
FS - FUEL SOLENOID	SM - STARTER MOTOR
GND - GROUND CONNECTION	TB - TERMINAL BLOCK, CAGE CLAMP
GOV - ELECTRONIC GOVERNOR ACTUATOR	WLS - COOLANT LEVEL SENDER
HVP - HIGH VOLTAGE PLUG 12-PIN (BULKHEAD)	WTS - COOLANT TEMPERATURE SENDER

NOTE: ALL WIRES 18 AWG
300V UL LISTED UNLESS
SHOWN OTHERWISE

AWG SIZE

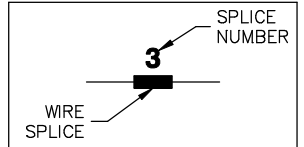

NOTE: ALL WIRES ON THIS
PAGE ARE 600V RATED

COMPONENTS LOCATED IN CUSTOMER CONNECTION BOX

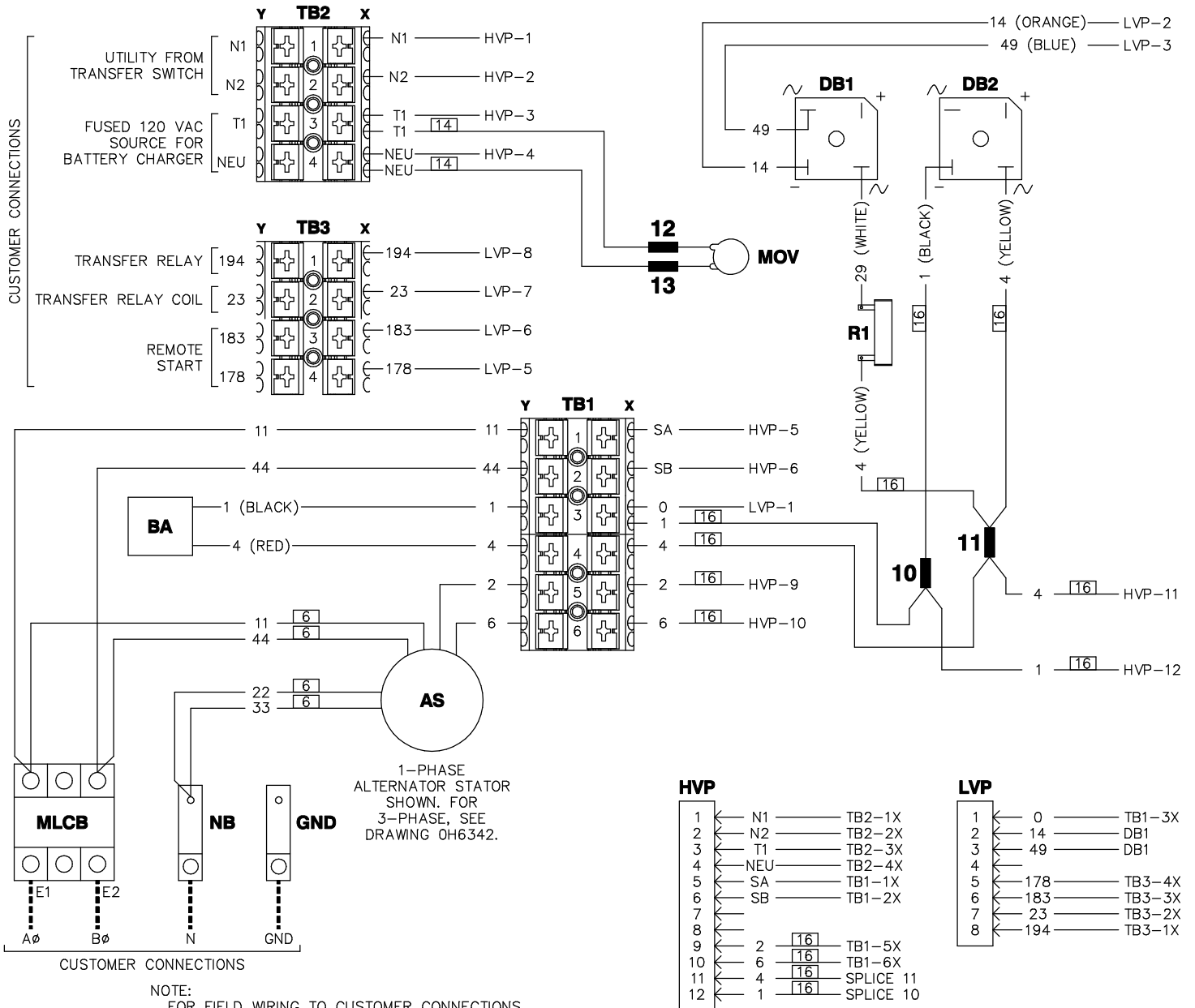

NOTE:
FOR FIELD WIRING TO CUSTOMER CONNECTIONS
(TERMINAL BLOCKS)
MAXIMUM WIRE SIZE: #12 AWG

COMPONENTS LOCATED ON ENGINE

J1		
1	178	LVR-5
2		
3		
4	817	BWR-2
5	818	BWR-3
6	15	SPLICE 2
7	15	SPLICE 2
8	0	SPLICE 1
9	0	SPLICE 1
10	0	MP1-2
11	0A	CAM-3
12	820	BWR-1
13	SA	HVR-5
14	183	LVR-6
15		
16	SHLD	MP1-1
17	819	BWR-4
18	767	GOV-2
19	765	GOV-3
20	766	GOV-6
21	68	WTS-2
22	0	SPLICE 1
23	79	MP1-3
24	SB	HVR-6
25	N1	HVR-1
26	N2	HVR-2
27		
28		
29		
30	15H	CAM-1
31	573A	WLS-A
32	573	WLS-B
33	86	LOS-NC
34	804	EC-6
35	805	EC-5

J2		
1	770	GOV-4
2	808	EC-4
3	56B	FS2
4	25A	CP-1
5	25B	CP-2
6		
7		
8	14	SPLICE 4
9	771	GOV-1
10	402	CAM-2
11	209	CAR
12	23	LVR-7
13	194	LVR-8
14	601	LFP
15	210	CAR
16	6	HVR-10
17	162	CB
18	4	HVR-11
19	1	HVR-12
20	T1	HVR-3
21	NEU	HVR-4
22	56	SC
23	15A	SPLICE 5

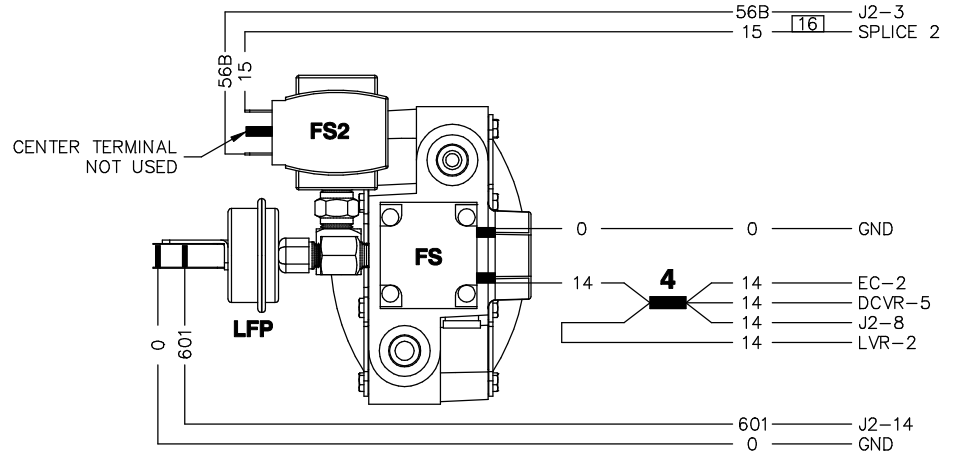

LOCATED BACK OF CUSTOMER CONNECTION BOX

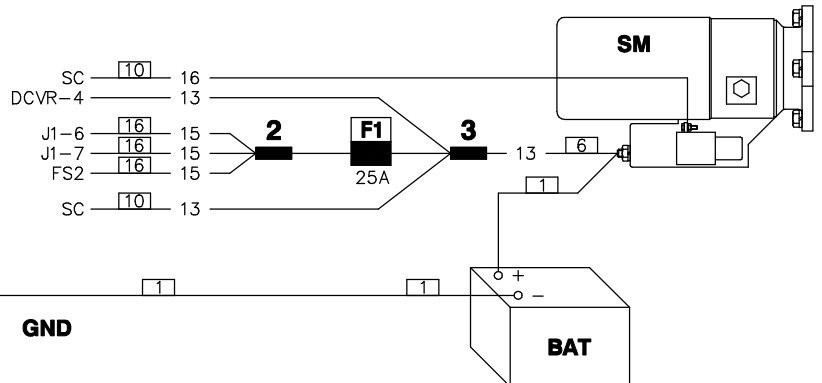
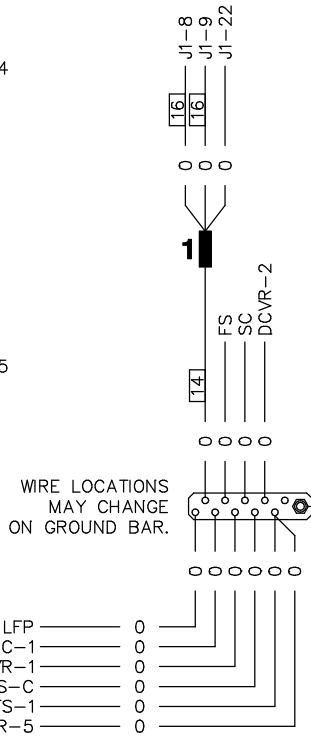
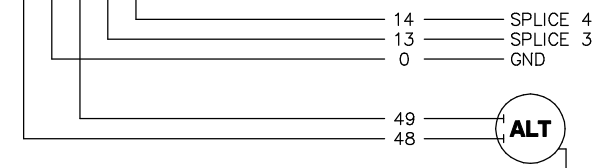
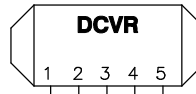
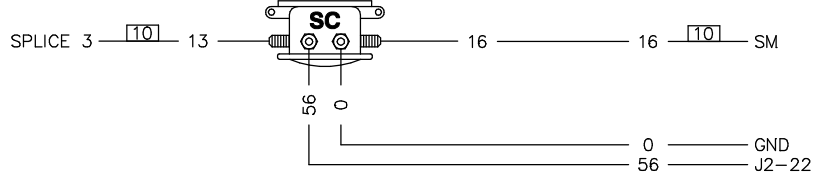

COMPONENTS LOCATED ON ENGINE

HVR

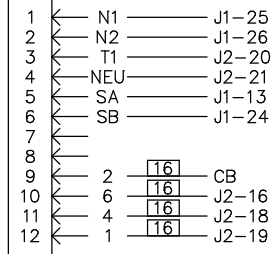

LVR

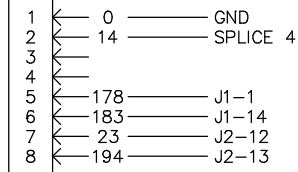

BWR

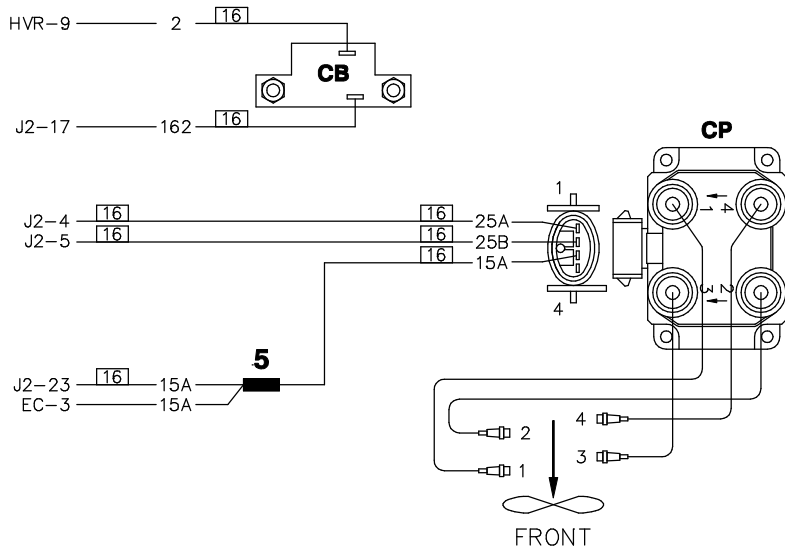
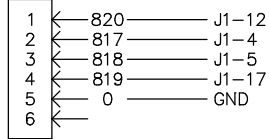

EC

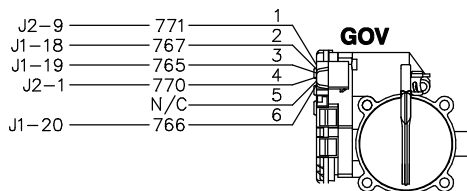
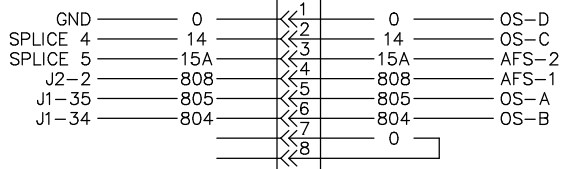

COMPONENTS LOCATED ON ENGINE

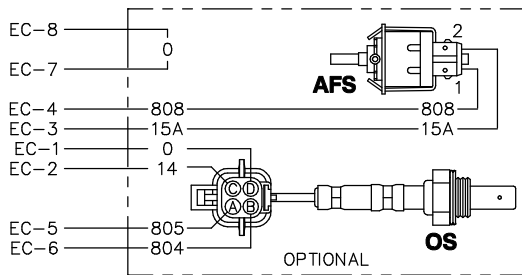
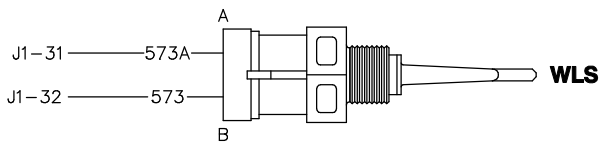
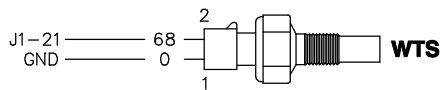
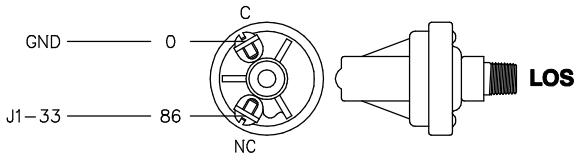
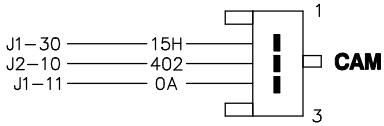
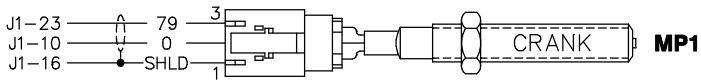



Owner's Manual

Stationary Emergency Generator

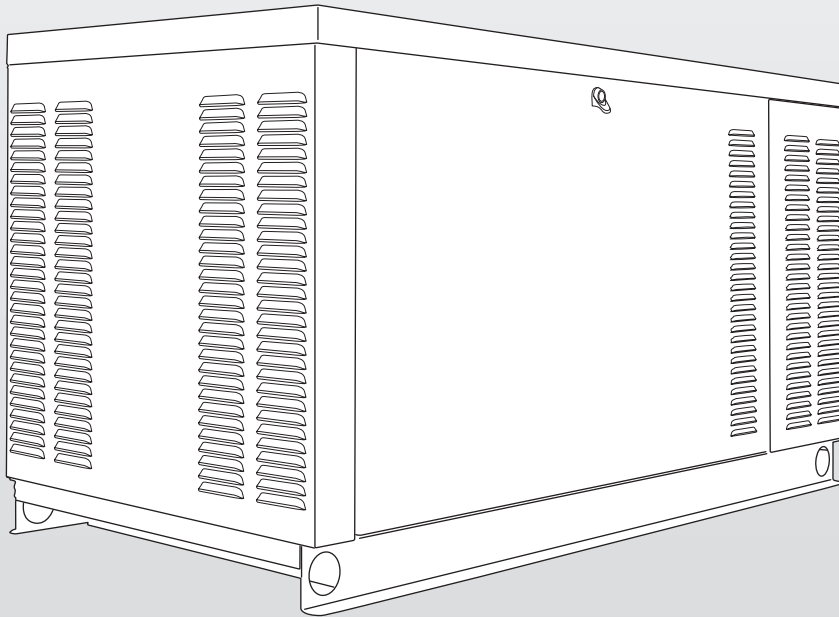

▲ CAUTION!

▲ NOT INTENDED FOR USE IN CRITICAL LIFE SUPPORT APPLICATIONS. ONLY QUALIFIED ELECTRICIANS OR CONTRACTORS SHOULD ATTEMPT INSTALLATION! DEADLY EXHAUST FUMES! OUTDOOR INSTALLATION ONLY!

1.6L
25/30kW Models
EPA Certified

This manual should remain with the unit.

Table of Contents

SECTION	PAGE		
INTRODUCTION	1-1		
Read this Manual Thoroughly	1-1		
Operation and Maintenance	1-1		
How to Obtain Service	1-1		
SAFETY RULES	1-2		
GENERAL INFORMATION	2-1		
Identification Record	2-1		
Data Label	2-1		
EQUIPMENT DESCRIPTION	3-1		
Equipment Description	3-1		
Engine Oil Recommendations	3-1		
Coolant Recommendations	3-1		
ENGINE PROTECTIVE DEVICES	4-1		
Engine Protective Devices	4-1		
High Coolant Temperature Sender	4-1		
Low Coolant Level Sensor	4-1		
Low Oil Pressure Switch	4-1		
Overcrank Shutdown	4-1		
Overspeed Shutdown	4-1		
RPM Sensor Loss Shutdown	4-1		
DC Fuses	4-1		
FUEL SYSTEM	5-1		
Fuel Requirements	5-1		
Natural Gas Fuel System	5-1		
Propane Vapor Withdrawal Fuel System	5-1		
LP Liquid Fuel System	5-1		
SPECIFICATIONS	6-1		
Stationary Emergency Generator	6-1		
Engine	6-1		
Cooling System	6-1		
Fuel System	6-1		
Electrical System	6-1		
Weather and Maintenance Kits	6-2		
Reconfiguring the Fuel System	6-2		
Fuel System	6-2		
Control Panel	6-2		
GENERAL INFORMATION	7-1		
Alternator AC Lead Connections	7-1		
Four-lead, Single-phase Stator	7-1		
Alternator Power Winding Connections	7-1		
3-phase Alternators ("Y" Configuration)	7-1		
3-phase Alternators ("Delta" Configuration)	7-2		
CONTROL PANEL	8-1		
Control Panel Interface	8-1		
Using the Auto/Off/Manual Switch	8-1		
Activate the Generator	8-1		
Display Interface Menus	8-1		
Activation Chart	8-2		
Setting the Exercise Timer	8-3		
Low Speed Exercise	8-3		
User Adjustable Settings	8-3		
Fuel Conversion	8-3		
Operation	8-3		
Automatic Transfer Operation	8-3		
Sequence of Automatic Operation	8-4		
Crank Cycles and Overcrank Shutdown	8-4		
Auto Start	8-4		
Manual Start	8-4		
		Alarm and Warning Messages	8-4
		Low Oil Pressure Shutdown Alarm	8-4
		High Coolant Temperature Shutdown Alarm	8-4
		Overcrank Shutdown Alarm	8-4
		Overspeed Shutdown Alarm	8-4
		RPM Sensor Failure Shutdown Alarm	8-4
		Under-frequency Shutdown Alarm	8-5
		Low Battery Alarm	8-5
		Low Battery Warning	8-5
		Low Coolant Level Alarm	8-5
		Missing Cam Pulse Alarm	8-5
		Missing Crank Pulse Alarm	8-5
		Low Fuel Pressure Warning	8-5
		Governor Sensor Fault Alarm	8-5
		Wiring Error Alarm	8-5
		Undervoltage Alarm	8-5
		Overvoltage Alarm	8-6
		Internal Failure Shutdown Alarm	8-6
		Canbus Alarm	8-6
		Ignition Alarm	8-6
		Maintenance Warning	8-6
		Alarm Cancel	8-6
		Common Alarm Relay	8-6
		Maintenance Alerts	8-6
		Menu System	8-7
		OPERATION	9-1
		Stationary Emergency Generator Control and Operation	9-1
		Operating Unit with Manual Transfer Switch	9-1
		Engine Start-up and Transfer	9-1
		Retransfer and Shutdown	9-1
		Operating Unit with Automatic Transfer Switch	9-1
		MAINTENANCE	10-1
		General Maintenance	10-1
		Check Engine Oil	10-1
		Changing Engine Oil	10-1
		Cooling Intake/Outlet	10-1
		Inspect Cooling System	10-1
		Engine Coolant	10-2
		Coolant Change	10-2
		Overload Protection for Engine DC Electrical System	10-2
		Exercise System	10-2
		Perform Visual Inspection	10-2
		Inspect Exhaust System	10-2
		Check Fan Belt	10-2
		Inspect Engine Governor	10-2
		Changing the Engine Air Filter	10-2
		Spark Plugs	10-3
		Battery Maintenance	10-3
		Battery Replacement	10-3
		Battery Fluid	10-3
		Cleaning the Stationary Emergency Generator	10-3
		SERVICE SCHEDULE	11-1
		TROUBLESHOOTING	12-1
		Troubleshooting Guide	12-1
		EMISSIONS WARRANTY	13-1
		NOTES	
		EXPLODED VIEWS & PARTS LISTS	
		WIRING DIAGRAMS & SCHEMATICS	

Safety Instructions

 **SAVE THESE INSTRUCTIONS** – The manufacturer suggests that these rules for safe operation be copied and posted in potential hazard areas. Safety should be stressed to all operators, potential operators, and service and repair technicians for this equipment.

INTRODUCTION

Thank you for purchasing this model of the stationary emergency generator product line.

Every effort was expended to make sure that the information and instructions in this manual were both accurate and current at the time the manual was written. However, the manufacturer reserves the right to change, alter or otherwise improve this product(s) at any time without prior notice.

READ THIS MANUAL THOROUGHLY

If any portion of this manual is not understood, contact the nearest Service Dealer for starting, operating and servicing procedures.

Throughout this publication, and on tags and decals affixed to the generator, DANGER, WARNING, CAUTION and NOTE blocks are used to alert personnel to special instructions about a particular service or operation that may be hazardous if performed incorrectly or carelessly. Observe them carefully. Their definitions are as follows:

DANGER!

INDICATES A HAZARDOUS SITUATION OR ACTION WHICH, IF NOT AVOIDED, WILL RESULT IN DEATH OR SERIOUS INJURY.

WARNING!

Indicates a hazardous situation or action which, if not avoided, could result in death or serious injury.

CAUTION!

Indicates a hazardous situation or action which, if not avoided, could result in minor or moderate injury.

NOTE:

Notes contain additional information important to a procedure and will be found within the regular text body of this manual.

These safety warnings cannot eliminate the hazards that they indicate. Common sense and strict compliance with the special instructions while performing the service are essential to preventing accidents.

Four commonly used safety symbols accompany the DANGER, WARNING and CAUTION blocks. The type of information each indicates is as follows:

 **This symbol points out important safety information that, if not followed, could endanger personal safety and/or property of others.**

 **This symbol points out potential explosion hazard.**

 **This symbol points out potential fire hazard.**

 **This symbol points out potential electrical shock hazard.**

The operator is responsible for proper and safe use of the equipment. The manufacturer strongly recommends that the operator read this Owner's Manual and thoroughly understand all instructions before using this equipment. The manufacturer also strongly recommends instructing other users to properly start and operate the unit. This prepares them if they need to operate the equipment in an emergency.

For safety reasons, the manufacturer recommends that this equipment be installed, serviced and repaired by a Service Dealer or other competent, qualified electrician or installation technician who is familiar with applicable codes, standards and regulations. The operator also must comply with all such codes, standards and regulations.

OPERATION AND MAINTENANCE

It is the operator's responsibility to perform all safety checks, to make sure that all maintenance for safe operation is performed promptly, and to have the equipment checked periodically by a Service Dealer. Normal maintenance service and replacement of parts are the responsibility of the owner/operator and, as such, are not considered defects in materials or workmanship within the terms of the warranty. Individual operating habits and usage contribute to the need for maintenance service.

Proper maintenance and care of the generator ensure a minimum number of problems and keep operating expenses at a minimum. See a Service Dealer for service aids and accessories.

Operating instructions presented in this manual assume that the generator electric system has been installed by a Service Dealer or other competent, qualified contractor. Installation of this equipment is not a "do-it-yourself" project.

HOW TO OBTAIN SERVICE

When the generator requires servicing or repairs, simply contact a Service Dealer for assistance. Service technicians are factory-trained and are capable of handling all service needs.

When contacting a dealer about parts and service, always supply the complete Model Number, Serial Number and Type Code (where applicable) from the DATA LABEL that is affixed to the unit.

Safety Instructions

SAFETY RULES

Study these SAFETY RULES carefully before installing, operating or servicing this equipment. Become familiar with this Owner's Manual and with the unit. The generator can operate safely, efficiently and reliably only if it is properly installed, operated and maintained. Many accidents are caused by failing to follow simple and fundamental rules or precautions.

The manufacturer cannot anticipate every possible circumstance that might involve a hazard. The warnings in this manual, and on tags and decals affixed to the unit are, therefore, not all inclusive. If a procedure, work method or operating technique is used that the manufacturer does not specifically recommend, ensure that it is safe for others. Also make sure the procedure, work method or operating technique utilized does not render the generator unsafe.

⚠ DANGER!

⚠ Despite the safe design of this generator, operating this equipment imprudently, neglecting its maintenance or being careless can cause possible injury or death. Permit only responsible and capable persons to install, operate or maintain this equipment.

⚠ Potentially lethal voltages are generated by these machines. Ensure all steps are taken to render the machine safe before attempting to work on the generator.

⚠ Parts of the generator are rotating and/or hot during operation. Exercise care near running generators.

GENERAL HAZARDS

- For safety reasons, the manufacturer recommends that this equipment be installed, serviced and repaired by a Service Dealer or other competent, qualified electrician or installation technician who is familiar with applicable codes, standards and regulations. The operator also must comply with all such codes, standards and regulations.
- Installation, operation, servicing and repair of this (and related) equipment must always comply with applicable codes, standards, laws and regulations. Adhere strictly to local, state and national electrical and building codes. Comply with regulations the Occupational Safety and Health Administration (OSHA) has established. Also, ensure that the generator is installed, operated and serviced in accordance with the manufacturer's instructions and recommendations. Following installation, do nothing that might render the unit unsafe or in noncompliance with the aforementioned codes, standards, laws and regulations.

- The engine exhaust fumes contain carbon monoxide gas, which can be DEADLY. This dangerous gas, if breathed in sufficient concentrations, can cause unconsciousness or even death. For that reason, adequate ventilation must be provided. This should be considered prior to installing the generator. The unit should be positioned to direct exhaust gasses safely away from any building where people, animals, etc., will not be harmed. Any exhaust stacks that ship loose with the unit must be installed properly per the manufacturer's instruction, and in strict compliance with applicable codes and standards.
- Keep hands, feet, clothing, etc., away from drive belts, fans, and other moving or hot parts. Never remove any drive belt or fan guard while the unit is operating.
- Adequate, unobstructed flow of cooling and ventilating air is critical in any room or building housing the generator to prevent buildup of explosive gases and to ensure correct generator operation. Do not alter the installation or permit even partial blockage of ventilation provisions, as this can seriously affect safe operation of the generator.
- Keep the area around the generator clean and uncluttered. Remove any materials that could become hazardous.
- When working on this equipment, remain alert at all times. Never work on the equipment when physically or mentally fatigued.
- Inspect the generator regularly, and promptly repair or replace all worn, damaged or defective parts using only factory-approved parts.
- Before performing any maintenance on the generator, disconnect its battery cables to prevent accidental start-up. Disconnect the cable from the battery post indicated by a NEGATIVE, NEG or (-) first. Reconnect that cable last.
- Never use the generator or any of its parts as a step. Stepping on the unit can stress and break parts, and may result in dangerous operating conditions from leaking exhaust gases, fuel leakage, oil leakage, etc.

ELECTRICAL HAZARDS

- All stationary emergency generators covered by this manual produce dangerous electrical voltages and can cause fatal electrical shock. Utility power delivers extremely high and dangerous voltages to the transfer switch as well as the generator. Avoid contact with bare wires, terminals, connections, etc., on the generator as well as the transfer switch, if applicable. Ensure all appropriate covers, guards and barriers are in place before operating the generator. If work must be done around an operating unit, stand on an insulated, dry surface to reduce shock hazard.
- Do not handle any kind of electrical device while standing in water, while barefoot, or while hands or feet are wet. DANGEROUS ELECTRICAL SHOCK MAY RESULT.

Safety Instructions

- If personnel must stand on metal or concrete while installing, operating, servicing, adjusting or repairing this equipment, place insulative mats over a dry wooden platform. Work on the equipment only while standing on such insulative mats.
- The National Electrical Code (NEC) requires the frame and external electrically conductive parts of the generator to be connected to an approved earth ground. This grounding will help prevent dangerous electrical shock that might be caused by a ground fault condition in the generator or by static electricity. Never disconnect the ground wire.
- Wire gauge sizes of electrical wiring, cables and cord sets must be adequate to handle the maximum electrical current (ampacity) to which they will be subjected.
- Before installing or servicing this (and related) equipment, make sure that all power voltage supplies are positively turned off at their source. Failure to do so will result in hazardous and possibly fatal electrical shock.
- Connecting this unit to an electrical system normally supplied by an electric utility shall be by means of a transfer switch so as to isolate the generator electric system from the electric utility distribution system when the generator is operating. Failure to isolate the two electric system power sources from each other by such means will result in damage to the generator and may also result in injury or death to utility power workers due to backfeed of electrical energy.
- Stationary emergency generators installed with an automatic transfer switch will crank and start automatically when normal (utility) source voltage is removed or is below an acceptable preset level. To prevent such automatic start-up and possible injury to personnel, disable the generator's automatic start circuit (battery cables, etc.) before working on or around the unit. Then, place a "Do Not Operate" tag on the generator control panel and on the transfer switch.
- In case of accident caused by electric shock, immediately shut down the source of electrical power. If this is not possible, attempt to free the victim from the live conductor. AVOID DIRECT CONTACT WITH THE VICTIM. Use a nonconducting implement, such as a dry rope or board, to free the victim from the live conductor. If the victim is unconscious, apply first aid and get immediate medical help.
- Never wear jewelry when working on this equipment. Jewelry can conduct electricity resulting in electric shock, or may get caught in moving components causing injury.

FIRE HAZARDS

- Keep a fire extinguisher near the generator at all times. Do NOT use any carbon tetra-chloride type extinguisher. Its fumes are toxic, and the liquid can deteriorate wiring insulation. Keep the extinguisher properly charged and be familiar with its use. If there are any questions pertaining to fire extinguishers, consult the local fire department.

EXPLOSION HAZARDS

- Properly ventilate any room or building housing the generator to prevent build-up of explosive gas.
- Do not smoke around the generator. Wipe up any fuel or oil spills immediately. Ensure that no combustible materials are left in the generator compartment, or on or near the generator, as FIRE or EXPLOSION may result. Keep the area surrounding the generator clean and free from debris.
- These generators may operate using one of several types of fuels. All fuel types are potentially FLAMMABLE and/or EXPLOSIVE and should be handled with care. Comply with all laws regulating the storage and handling of fuels. Inspect the unit's fuel system frequently and correct any leaks immediately. Fuel supply lines must be properly installed, purged and leak tested according to applicable fuel-gas codes before placing this equipment into service.
- Diesel fuels are highly FLAMMABLE. Gaseous fluids such as natural gas and liquid propane (LP) gas are extremely EXPLOSIVE. Natural gas is lighter than air, and LP gas is heavier than air; install leak detectors accordingly.

CALIFORNIA PROPOSITION 65 WARNING

Engine exhaust and some of its constituents are known to the State of California to cause cancer, birth defects and other reproductive harm.

CALIFORNIA PROPOSITION 65 WARNING

This product contains or emits chemicals known to the State of California to cause cancer, birth defects and other reproductive harm.

General Information

IDENTIFICATION RECORD

DATA LABEL

Every generator set has a DATA LABEL that contains important information pertinent to the generator. The data label, which can be found attached to the generator's lower connection box, lists the unit's serial number and its rated voltage, amps, wattage capacity, phase, frequency, rpm, power factor, production date, etc.

NOTE:

For actual information related to this particular model, please refer to the Manual Drawing Listing located at the end of this manual, or to the data label affixed to the unit.

Stationary Emergency Generator Model and Serial Number

This number is the key to numerous engineering and manufacturing details pertaining to your unit. Always supply this number when requesting service, ordering parts or seeking information.

Data Label

MODEL <input style="width: 200px;" type="text"/>		<input style="width: 150px;" type="text"/>	
PROD DATE <input style="width: 150px;" type="text"/>		SERIAL <input style="width: 200px;" type="text"/>	
KW <input style="width: 50px;" type="text"/>	KVA <input style="width: 50px;" type="text"/>	PHASE <input style="width: 50px;" type="text"/>	HERTZ <input style="width: 50px;" type="text"/>
VOLT <input style="width: 50px;" type="text"/>	AMP <input style="width: 50px;" type="text"/>	PWR FACT <input style="width: 50px;" type="text"/>	ALT RPM <input style="width: 50px;" type="text"/>
ENG RPM <input style="width: 100px;" type="text"/>		TYPE CODE <input style="width: 100px;" type="text"/>	
ALT SUBTRANS REACTANCE <input style="width: 100px;" type="text"/>		ALT TRANS REACTANCE <input style="width: 100px;" type="text"/>	
CLASS <input type="checkbox"/> ROTOR <input type="checkbox"/> STATOR WINDING INS AT 25°C AMB			
<input style="width: 100%; height: 20px;" type="text"/>		<input style="width: 100%; height: 20px;" type="text"/>	
MODEL NO (CAT/CUST NO)		SERIAL NO	
<input style="width: 100%; height: 20px;" type="text"/>		<input style="width: 100%; height: 20px;" type="text"/>	
<input style="width: 100%; height: 20px;" type="text"/>		<input style="width: 100%; height: 20px;" type="text"/>	

0G2110 REV C

EQUIPMENT DESCRIPTION

This equipment is a revolving field, alternating current Stationary Emergency Generator. It is powered by a gaseous fueled engine operating at 1800 rpm for 4-pole direct drive units, 3600 rpm for 2-pole direct drive units and 2300 - 3000 rpm for quiet drive gear units. See the Specifications section for exact numbers. The unit comes complete with a sound attenuated enclosure, internally mounted muffler, control console, mainline circuit breaker, battery charger, and protective alarms as explained in the following paragraph.

All AC connections, including the power leads from the alternator, 120 volt battery charger input and control connections to the transfer switch are available in the main connection box.

The Stationary Emergency Generator incorporates the following alternator features:

- Rotor and Stator insulation is Class F rated as defined by NEMA MG1-32.6, NEMA MG1-1.66. The generator is self ventilated and drip-proof constructed.
- The voltage waveform deviation, total harmonic content of the AC waveform and telephone influence factor have been evaluated and are acceptable according to NEMA MG1-32.

ENGINE OIL RECOMMENDATIONS

The unit has been filled with 5W-20 engine oil at the factory. Use a high-quality detergent oil classified "For Service SJ or SH." Detergent oils keep the engine cleaner and reduce carbon deposits. When changing the engine oil, be sure to use 5W-30 engine oil (synthetic oil is recommended).

⚠ CAUTION!

⚠ Any attempt to crank or start the engine before it has been properly serviced with the recommended oil may result in an engine failure.

NOTE:

For temperatures below 32° F, it is strongly recommended to use the optional Cold Weather Start Kit. The oil grade for temperatures below 32° F is 5W-30 synthetic oil.

COOLANT RECOMMENDATIONS

Use a mixture of half low silicate ethylene glycol base anti-freeze and deionized water. Cooling system capacity is listed in the specifications. Use only deionized water and only low silicate anti-freeze. If desired, add a high quality rust inhibitor to the recommended coolant mixture. When adding coolant, always add the recommended 50-50 mixture.

⚠ CAUTION!

⚠ Do not use any chromate base rust inhibitor with ethylene glycol base anti-freeze or chromium hydroxide ("green slime") forms and will cause overheating. Engines that have been operated with a chromate base rust inhibitor must be chemically cleaned before adding ethylene glycol base anti-freeze. Using any high silicate anti-freeze boosters or additives will also cause overheating. The manufacturer also recommends that any soluble oil inhibitor is NOT used for this equipment.

⚠ DANGER!

⚠ Do not remove the radiator pressure cap while the engine is hot or serious burns from boiling liquid or steam could result.

⚠ Ethylene glycol base antifreeze is poisonous. Do not use mouth to siphon coolant from the radiator, recovery bottle or any container. Wash hands thoroughly after handling. Never store used antifreeze in an open container because animals are attracted to the smell and taste of antifreeze even though it is poisonous to them.

Engine Protective Devices

ENGINE PROTECTIVE DEVICES

The Stationary Emergency Generator may be required to operate for long periods of time without an operator on hand to monitor such engine conditions as coolant temperature, oil pressure or rpm. For that reason, the engine has several devices designed to protect it against potentially damaging conditions by automatically shutting down the unit when the oil pressure is too low, the coolant temperature is too high, the coolant level is too low, or the engine is running too fast.

NOTE:

Engine protective switches and sensors are mentioned here for the reader's convenience. Also refer to the applicable control panel manual for additional automatic engine shutdown information.

HIGH COOLANT TEMPERATURE SENDER

An analog coolant temperature sender, located in the engine's cooling system will cause an engine shutdown if the temperature should exceed approximately 125° C (257° F). The generator will automatically restart once the temperature has returned to a safe operating level.

LOW COOLANT LEVEL SENSOR

To prevent overheating, the engine has a low coolant level sensor. If the level of engine coolant drops below the level of the low coolant level sensor, the engine automatically shuts down.

LOW OIL PRESSURE SWITCH

This switch has normally closed contacts that are held open by engine oil pressure during cranking and operating. Should oil pressure drop below the 8 psi range, switch contacts close, and the engine shuts down. The unit should not be restarted until oil is added, and the AUTO/OFF/MANUAL switch must be turned to OFF and then back to AUTO.

OVERCRANK SHUTDOWN

After a prespecified duration of cranking, this function ends the cranking if the engine has failed to start. The overcrank message will turn ON. Turn OFF the AUTO/OFF/MANUAL switch, then turn switch back to AUTO to reset the generator control board.

NOTE:

If the fault is not corrected, the overcrank feature will continue to activate.

Approximate Crank Cycle Times

- 15 seconds ON
- 7 seconds OFF
- 7 seconds ON
- 7 seconds OFF
- Repeat for 45 seconds
- Approximately 90 seconds total.

OVERSPEED SHUTDOWN

A speed circuit controls engine cranking, start-up, operation and shutdown. Engine speed signals are delivered to the circuit board whenever the unit is running. Should the engine overspeed above a safe, preset value, the circuit board initiates an automatic engine shutdown. Contact the nearest Authorized Dealer if this failure occurs.

RPM SENSOR LOSS SHUTDOWN

If the speed signal to the control panel is lost, engine shutdown will occur.

DC FUSES

A fuse (7.5 amp) is located on the control panel. It protects the panel components from damaging overload. **Always remove this fuse before commencing work on the generator.** The unit will not start or crank if the fuse is blown.

A fuse (25 amp) is located in the engine wire harness adjacent to the DC alternator. It is used to prevent circuit failure due to DC alternator failure. It will also protect the system in the event of a wiring short-circuit. If this fuse is blown, the generator will not operate. Replace these fuses with the same size, type, and rating.

FUEL SYSTEM

FUEL REQUIREMENTS

The Stationary Emergency Generator may be equipped with one of the following fuel systems:

- Natural gas fuel system
- Propane vapor (LPV) fuel system

Recommended fuels should have a Btu content of at least 1,000 Btu's per cubic foot for natural gas; or at least 2,520 Btu's per cubic foot for LP gas. Ask the fuel supplier for the Btu content of the fuel.

NOTE:

The fuel consumption requirements are identified in the Specifications section of the Owner's Manual. Refer to the Installation Manual if assistance is required for the sizing of the pipe diameter for the generator. Any piping used to connect the generator to the fuel supply should be of adequate size to achieve the 100% load fuel consumption requirements identified in the Specifications section regardless of actual load.

NOTE:

The recommended fuel pressure is identified in the Specifications section this manual.

NOTE:

It is the responsibility of the installer to make sure that only the correct recommended fuel is supplied to the generator fuel system. Thereafter, the owner/operator must make certain that only the proper fuel is supplied.

NATURAL GAS FUEL SYSTEM

Natural gas is supplied in its vapor state. In most cases, the gas distribution company provides piping from the main gas distribution line to the standby generator site. The following information applies to natural gas fuel systems.

- Gas pressure in a building is usually regulated by national, state and local codes.
- To reduce gas pressure to a safe level before the gas enters a building, a primary regulator is needed. The natural gas supplier may or may not supply such a regulator.
- It is the responsibility of the gas supplier to make sure sufficient gas pressure is available to operate the primary regulator.
- Gas pressure at the inlet to the fuel shutoff solenoid must never exceed approximately 14 inches water column (0.5 psi).

PROPANE VAPOR WITHDRAWAL FUEL SYSTEM

This type of system utilizes the vapors formed above the liquid fuel in the supply tank. Approximately 10 to 20 percent of the tank capacity is needed for fuel expansion from the liquid to the vapor state. The vapor withdrawal system is generally best suited for smaller engines that require less fuel. The installer should be aware of the following:

- When ambient temperatures are low and engine fuel consumption is high, the vapor withdrawal system may not function efficiently.
- Ambient temperatures around the supply tank must be high enough to sustain adequate vaporization, or the system will not deliver the needed fuel volume.
- In addition to the cooling effects of ambient air, the vaporization process itself provides an additional cooling effect.

Specifications

SPECIFICATIONS

STANDBY EMERGENCY GENERATOR

Type.....Synchronous
 Rotor Insulation..... Class H
 Stator Insulation..... Class H
 Alternator Output Leads 3-phase..... 4-wire
 Bearings Sealed Ball
 Coupling Flexible Disc
 Load Capacity (Standby Rating)25/30 kW*

* NOTE: Generator rating and performance in accordance with ISO8528-5, BS5514, SAE J1349, ISO3046 and DIN 6271 Standards. KW rating is based on LPG fuel and may derate with natural gas.

Excitation System Direct
 Generator Output Voltage/kW - 60 Hz

	kW	Amp	CB Size
120/240V, 1-phase, 1.0 pf	25/30	104/125	125/150
120/208V, 3-phase, 0.8 pf	25/30	87/104	100/125
120/240V, 3-phase, 0.8 pf	25/30	75/90	90/100

Generator Locked Rotor KVA Available @ Voltage Dip of 35%

	25kW	30kW
	35 KVA	45 KVA

ENGINE

Make Generac
 ModelIn Line
 Cylinders and Arrangement..... 4
 Displacement..... 1.6 Liter
 Bore..... 3.15 in.
 Stroke..... 3.13 in.
 Compression Ratio..... 9.5-to-1
 Air Intake System..... Naturally Aspirated
 Valve Seats Replaceable
 Lifter Type..... Hydraulic
 Spark Plug Gap..... 0.76mm (0.030 inch)

Engine Parameters

Rated Synchronous RPM60 Hz, 3600

Exhaust System

Exhaust Flow at Rated Output 60 Hz: 25kW 30kW
 240 cfm 260 cfm
 Exhaust Temp. at Rated Output: 975°F 1025°F

Combustion Air Requirements (Natural Gas)

Flow at rated power, 60 Hz: 25kW 30kW
 90 cfm 95 cfm

Governor

Type.....Electronic
 Frequency Regulation.....Isochronous
 Steady State Regulation ± .25%
 Adjustments:
 Speed..... Selectable

Engine Lubrication System

Type of Oil PumpGear
 Oil FilterFull Flow, Cartridge
 Crankcase Oil Capacity 4 U.S. qts.

COOLING SYSTEM

Type..... Closed
 Water Pump..... Belt Driven
 Fan Speed..... 2484
 Fan Diameter..... 17.7 inches
 Fan Mode..... Pusher
 Air Flow (inlet air including alternator and combustion air) 1800 ft³/min.
 Coolant Capacity.....2.0 U.S. gal.
 Heat Rejection to Coolant (25/35kW)112,000/135,000 Btu/h
 Maximum Operating Air Temp. on Radiator..... 60° C (150° F)
 Maximum Ambient Temperature 50° C (140° F)

FUEL SYSTEM

Type of FuelNatural Gas, Propane Vapor
 Carburetor..... Down Draft
 Secondary Fuel Regulator..... Standard
 Fuel Shut-off Solenoid..... Standard
 Operating Fuel Pressure 5 in. - 14 in. Water Column

Fuel Consumption - ft³/hr (Natural Gas/LPV)

	Exercise Cycle	25% Load	50% Load	75% Load	100% Load
25kW	60/24	120/48	220/87	310/123	390/155
30kW	60/24	145/58	260/103	370/147	470/187

ELECTRICAL SYSTEM

Battery Charge Alternator 12V, 15 Amp
 Static Battery Charger 2.0 or 2.5 Amp
 Recommended Battery.....Group 26, 525CCA
 System Voltage..... 12 Volts

Voltage Regulator

Type..... Electronic
 Sensing Single-phase
 Regulation..... ± 1%
 Features..... Adjustable Voltage and Automatic Gain

Power Adjustment for Ambient Conditions

Temperature Deration:
 3% for every 10° C above °C 25kW 30kW
 40 25
 1.65% for every 10° above °F 104 77
 Altitude Deration:
 1% for every 100 m above m 25kW 30kW
 915 182
 3% for every 1000 ft. above ft. 2000 600

Controller Nexus

Specifications

WEATHER AND MAINTENANCE KITS

To keep the generator running at its peak, the following kits are offered:

- Cold Weather Kit
 - ~ Recommended for climates with temperatures below 32° F.
- Extreme Cold Weather Kit
 - ~ Recommended Block Heater Kit for protection in temperatures below 32° F.
- Scheduled Maintenance Kit
 - ~ Kit includes the recommended parts to maintain the generator. Refer to the Service Schedule for regular maintenance intervals.

For additional information, or to order any of these kits, please contact an Authorized Service Dealer or Customer Service Representative.

RECONFIGURING THE FUEL SYSTEM

NOTE:

All models are configured to run on natural gas from the factory.

Before the generator can be operated using a LP fuel source, the fuel system and control panel (refer to the installation drawing for location) must be reconfigured. The steps to reconfigure the generator from a natural gas (NG) to a liquidified petroleum (LP) fuel source are as follows:

FUEL SYSTEM

1. Turn the main gas supply off and disconnect the battery.
2. Remove the carburetor fuel hose from the outlet port of the demand regulator (see Figure 6.1).
3. Disconnect the power wires from the fuel solenoid located on top of the regulator assembly by removing the screw on the front of the connector and pulling the connector forward, away from the solenoid body.
4. Loosen the spring clamp on the small fuel enrichment line and remove the hose from the hose barb.
5. Remove the black pipe assembly from the outlet port of the demand regulator. The solenoid assembly may need to be removed before performing this operation (Figure 6.1).
6. Remove the NG fuel jet (loosen counter clockwise) from the outlet port.
7. Remove the LP fuel jet (loosen counter clockwise) from the jet keeper port on the side of the regulator housing. Install this jet into the outlet port in the regulator casting.

NOTE:

The jet sizes are stamped on the individual jets. The larger jet size is used for running on NG.

8. Install the previously removed NG jet into the jet keeper port on the side of the regulator housing.

9. Install the previously removed black pipe onto the outlet port of the demand regulator. Use pipe sealant on the pipe threads.
10. Reverse steps 1-4 in this procedure to reactivate the demand regulator.
11. Follow the instructions in the Control Panel section.

⚠ DANGER!

⚠ Serious injury, including death, or damage will occur if not configured properly. Please consult an Authorized Dealer with any questions.

Figure 6.1 — Reconfigure the Fuel System

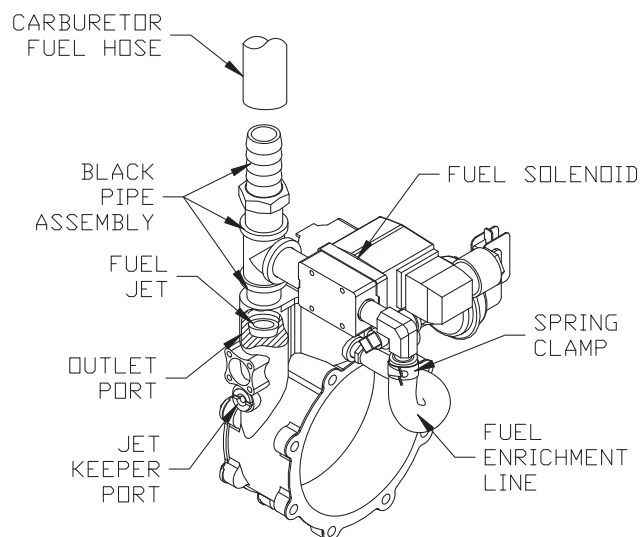

CONTROL PANEL

The FUEL TYPE must be reconfigured in the control panel to finalize the conversion process. This generator is configured at the factory to operate on natural gas. If conversion to LP is required, please complete the mechanical conversion process and then call 888-9ACTIVATE for the control panel password. This fuel selection conversion is required to be password protected by Environmental Protection Agency [EPA] regulations.

⚠ CAUTION!

⚠ Whenever the Generator's Fuel Regulator is converted from one Fuel type to the other, the Control Panel must be reconfigured for the correct fuel type. Failure to convert both the Regulator and Control Panel will result in decreased performance and an increase in emissions, and is a violation of EPA regulations.

ALTERNATOR AC LEAD CONNECTIONS

The electrical wires in the unit's AC connection (lower) panel should be installed according to the number of leads and the voltage/phase required for the application. The voltage and phase are described on the generator data label. The number of lead wires can be identified using the Specifications section and the power output rating on the generator data label. For example, if the generator produces 130kW, 277/480 Volt, 3-phase power, the generator has 12 alternator output leads. Figure 7.3 describes the stator power winding connection for the generator.

FOUR-LEAD, SINGLE-PHASE STATOR

Four-lead alternators (see Figure 7.1) are designed to supply electrical loads with voltage code "A" (240V, 1-phase, 60 Hz). Electrical power is produced in the stator power windings. These windings were connected at the factory to the main circuit breaker as shown in Figure 7.1.

The rated voltage between each circuit breaker terminal is 240V. The rated voltage between each circuit breaker terminal and the neutral point 00 is 120V.

Figure 7.1 — Four-lead, Single-phase Stator

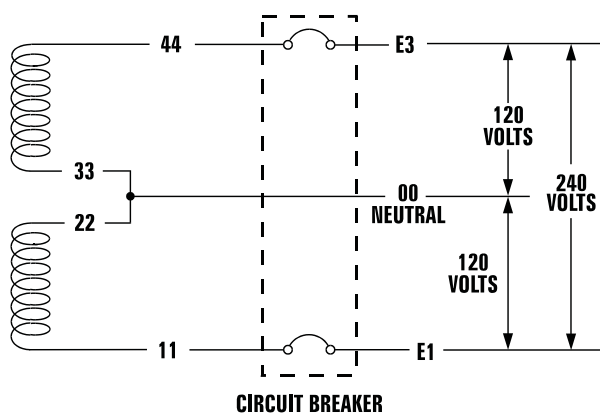

ALTERNATOR POWER WINDING CONNECTIONS

3-PHASE ALTERNATORS ("Y" CONFIGURATION)

The Stationary Emergency Generator is designed to supply 3-phase electrical loads. Electric power is produced in the alternator power windings. These windings were connected at the factory to the main circuit breaker with a "Y" configuration as shown in Figures 7.2 through 7.6.

The rated voltage between circuit breaker terminals E1-E2, E1-E3 and E2-E3 is 480V, 208V or 600V depending on the model.

The rated voltage between each circuit breaker terminal and the neutral point 00 is 277V, 120V, or 346V depending on the model.

Figure 7.2 — Stator Power Winding Connections - 3-phase, 277/480V (6 Lead)

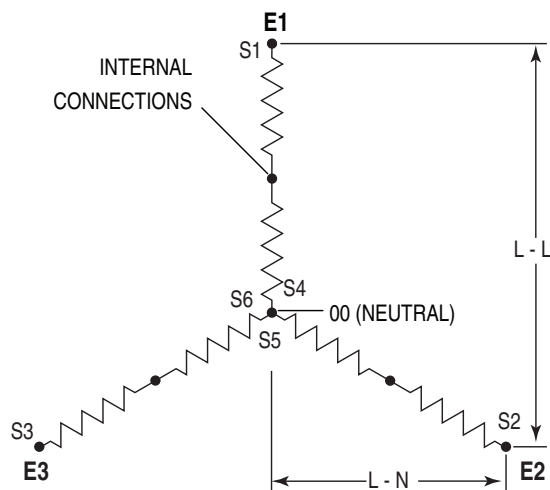
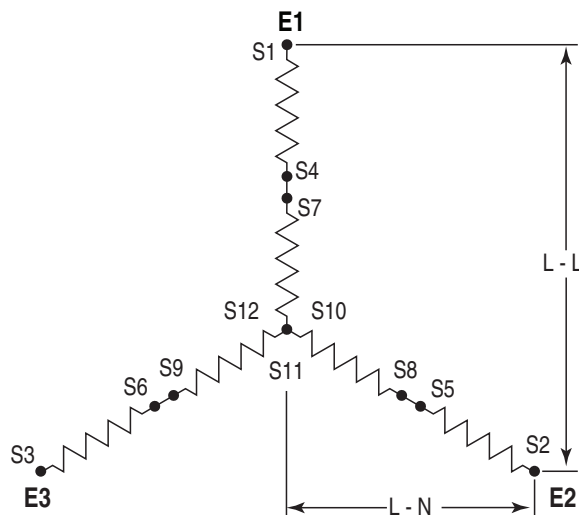

Figure 7.3 — Stator Power Winding Connections - 3-phase, 277/480V (12 Lead)



General Information

Figure 7.4 — Stator Power Winding Connections - 3-phase, 120/208V (6 Lead)

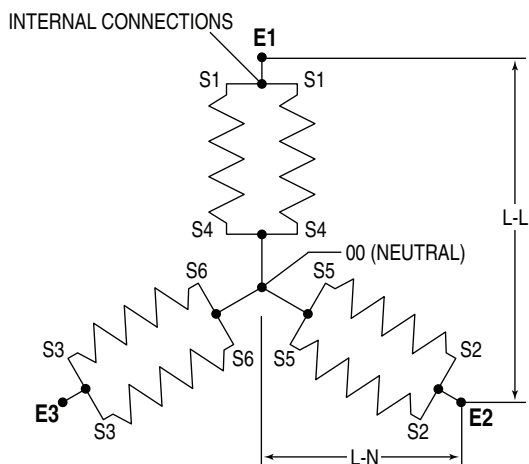

Figure 7.5 — Stator Power Winding Connections - 3-phase, 120/208V (12 Lead)

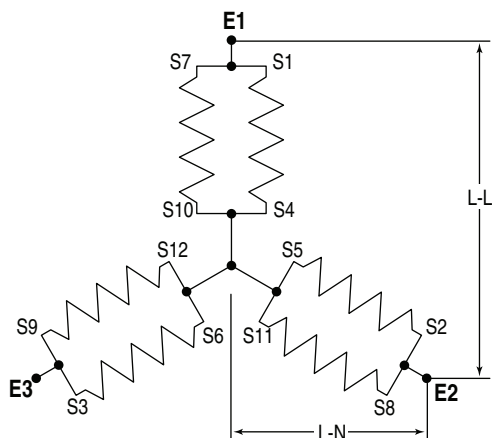
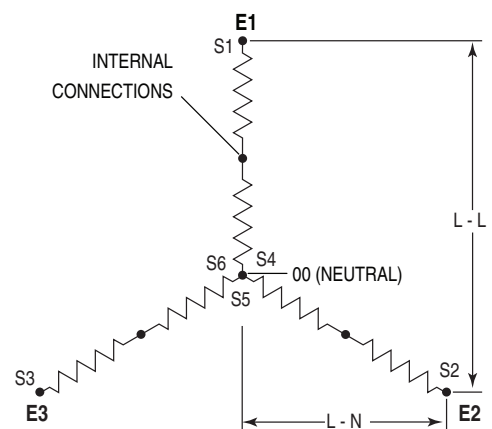

Figure 7.6 — Stator Power Winding Connections - 3-phase, 346/600V (6 Lead)



3-PHASE ALTERNATORS ("DELTA" CONFIGURATION)

The Stationary Emergency Generator is designed to supply 3-phase electrical loads. Electric power is produced in the alternator power windings. These windings were connected at the factory to the main circuit breaker with a "Delta" configuration as shown in Figures 7.7 and 7.8.

The rated voltage between circuit breaker terminals E1-E2, E1-E3 and E2-E3 is 240V.

The rated voltage between E1 or E3 and the neutral point 00 is 120V.

Figure 7.7 — Stator Power Winding Connections - 3-phase, 120/240V (6 Lead)

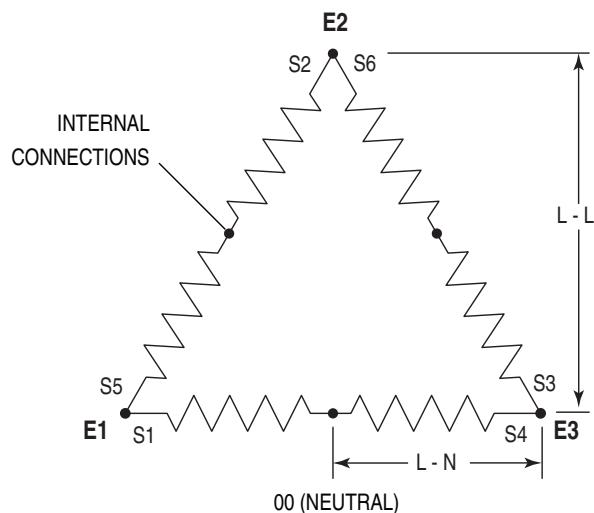
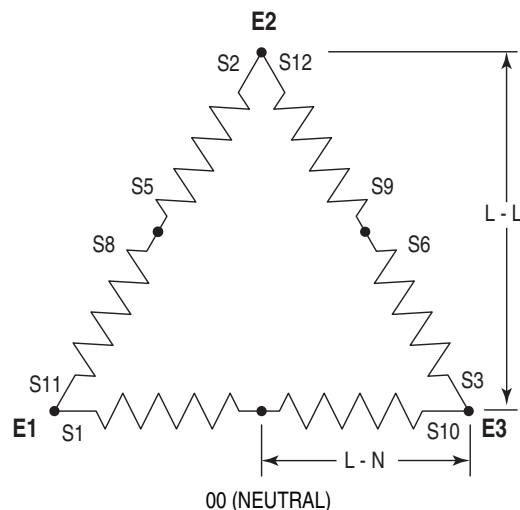

Figure 7.8 — Stator Power Winding Connections - 3-phase, 120/240V (12 Lead)



CONTROL PANEL INTERFACE

USING THE AUTO/OFF/MANUAL SWITCH

⚠ WARNING!

⚠ With the switch set to AUTO, the engine may crank and start at any time without warning. Such automatic starting occurs when utility power source voltage drops below a preset level or during the normal exercise cycle. To prevent possible injury that might be caused by such sudden starts, always set the switch to OFF and remove the fuse before working on or around the generator or transfer switch. Then, place a “DO NOT OPERATE” tag on the generator panel and on the transfer switch.

1. “AUTO” Position – Selecting this switch activates fully automatic system operation. It also allows the unit to automatically start and exercise the engine every seven days with the setting of the exercise timer (see the Setting the Exercise Timer section).
2. “OFF” Position – This switch position shuts down the engine. This position also prevents automatic operation.
3. “MANUAL” Position – Set the switch to MANUAL to crank and start the engine. Transfer to standby power will not occur unless there is a utility failure.

ACTIVATE THE GENERATOR

When battery power is applied to the generator during the installation process, the controller will turn ON and the LCD screen will illuminate. However, the generator still needs to be activated before it will automatically run in the event of a power outage.

Activating the generator is a simple one time process that is guided by the controller screen prompts. Once the product is activated, the controller screen will not prompt you again, even if you disconnect the generator battery.

To obtain the activation code, record the generator serial number and log onto www.activategen.com or call 1-888-9ACTIVATE and follow the steps to retrieve the activation code.

After obtaining your activation code, please complete the following steps at the generator’s control panel in the Activation Chart on the following page.

NOTE:

The generator will only run in manual until the passcode has been entered.

Upon power up, this controller will go through a system self test which will check for the presence of utility voltage on the DC circuits. This is done to prevent damage if the installer mistakenly connects AC utility power sense wires into the DC terminal block. If utility voltage is detected, the controller will display a warning message and lock out the generator, preventing damage to the controller. Power to the controller must be removed to clear this warning.

Utility voltage must be turned on and present at the N1 and N2 terminals inside the generator control panel for this test to be performed and pass.

NOTE:

DAMAGE CAUSED BY MISWIRING OF THE INTERCONNECT WIRES IS NOT WARRANTABLE!

This test will be performed each time the controller is powered up.

Next, the user must enter the minimum settings to operate. These settings are current date and time and exercise day and time. The maintenance intervals will be initialized (i.e. started) the first time the clock is set. If the clock is never set at power up, the maintenance intervals will be reset every time power is applied.

If a subsequent power loss (loss of battery power) occurs the Installation assistant will operate upon power restoration. The self test routine will be run and then the customer will be required to re-enter the time and date, as this is not retained during a power loss. The unit will not require re-activation.



DISPLAY INTERFACE MENUS

The LCD display is organized as detailed below:

- The “Home” page, this page is the default page which will be displayed if no keys are pressed for 30 seconds. This page normally shows the current Status message and the current date and time. The highest priority active Alarm and/or Warning will be automatically posted on this page as well as flashing the backlight when such an event is detected. In the case of multiple Alarms or Warnings, only the first message will be displayed. To clear an Alarm or Warning, see the Protection Systems section - Clear Alarm.
- The display backlight is normally off. If the user presses any key, the backlight will come on automatically and remain on for 30 seconds after the last key was pressed.
- The “Main Menu” page will allow the user to navigate to all other pages or sub-menus by using the Left/Right and Enter keys. This page can be accessed at any time with several presses of the dedicated Escape key. Each press of the Escape key takes you back to the previous menu until the main menu is reached. This page displays the following options: HISTORY; STATUS; EDIT; AND DEBUG. (See the Appendix - “Menu System”.)

Control Panel

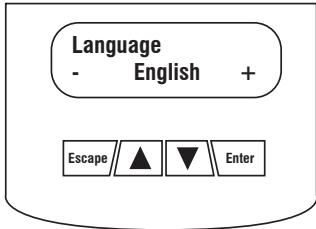
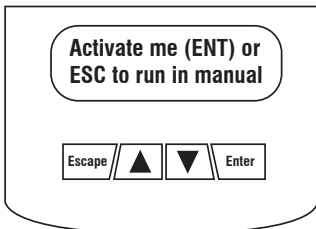
ACTIVATION CHART

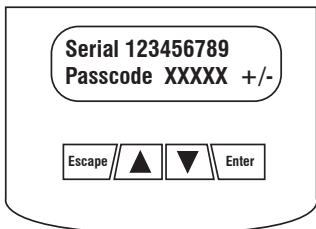
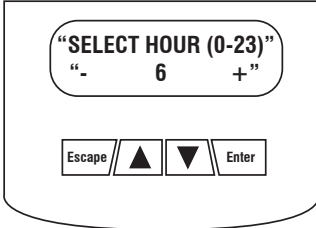
CHOOSE LANGUAGE		TROUBLESHOOTING
<p>Display Reads:</p> 	<p>Use ARROW keys to scroll to desired language. Press ENTER to select.</p>	<p>If the wrong language is chosen, it can be changed later using the "edit" menu.</p>
<p>Display Reads:</p> 	<p>Press ENTER to begin the activation process.</p>	<p>If ESCAPE is pressed instead of ENTER, your generator will only run in manual mode (for test purposes) and NOT ACTIVATED will be displayed. You will need to remove the generator control panel fuse AND disconnect the T1, N1 and N2 connector in the external connection box (if equipped); or disconnect utility input (main breaker) to the transfer switch for 3-5 seconds and reconnect, then begin with Step 1.</p>
<p>Display Reads:</p> 	<p>If you do not have your activation code, go to www.activategen.com or call 1-888-9ACTIVATE (922-8482). If you already have your activation code, wait 3-5 seconds for the next display.</p>	
ENTER ACTIVATION CODE (Passcode)		TROUBLESHOOTING
<p>Display Reads:</p> 	<p>Use ARROW keys to scroll and find the first number of your Activation Code. Press ENTER to select. Repeat this step until all digits have been entered. Use ESCAPE to correct previous digits.</p>	
<p>Display Reads:</p> 	<p>Activation is complete when all digits are entered above and your screen shows this display. Follow the controller prompts to continue setting the time function. Refer to your Owner's Manual with questions.</p>	<p>What happens if "Wrong Passcode Try Again" appears? Re-enter the activation code. If a second attempt is unsuccessful, check the number against the code given on activategen.com. If it is correct and the generator will not accept it, contact 1-888-9ACTIVATE (922-8482).</p>

Control Panel

INSTALLATION ASSISTANT

Interconnect System Self Test Feature (follow the on-screen prompts).

Upon power up, this controller will go through a system self test which will check for the presence of utility voltage on the DC circuits. This is done to prevent damage if the installer mistakenly connects AC utility power sense wires into the DC terminal block. If utility voltage is detected, the controller will display a warning message and lock out the generator, preventing damage to the controller. Power to the controller must be removed to clear this warning.

Utility voltage must be turned on and present at the N1 and N2 terminals inside the generator control panel for this test to be performed and pass.

NOTE:

DAMAGE CAUSED BY MISWIRING OF THE INTERCONNECT WIRES IS NOT WARRANTABLE!

This test will be performed each time the controller is powered up.

Upon first power up of the generator, the display interface will begin an installation assistant. The assistant will prompt the user to set the minimum settings to operate. These settings are simply: Current Date/Time and Exercise Day/Time. The maintenance intervals will be initialized when the exercise time is entered.

The exercise settings can be changed at any time via the "EDIT" menu (see Appendix, "Menu System").

If the 12 volt battery is disconnected or the fuse removed, the Installation Assistant will operate upon power restoration. The only difference is the display will only prompt the customer for the current Time and Date.

IF THE INSTALLER TESTS THE GENERATOR PRIOR TO INSTALLATION, PRESS THE "ENTER" KEY TO AVOID SETTING UP THE EXERCISE TIME. THIS WILL ENSURE THAT WHEN THE CUSTOMER POWERS UP THE UNIT, HE WILL STILL BE PROMPTED TO ENTER AN EXERCISE TIME.

SETTING THE EXERCISE TIMER

This generator is equipped with an exercise timer. Once it is set, the generator will start and exercise every seven days, on the day of the week and at the time of day specified. During this exercise period, the unit runs for approximately 12 minutes and then shuts down. Transfer of loads to the generator output does not occur during the exercise cycle unless utility power is lost.

LOW SPEED EXERCISE

The standard start sequence will be initiated.

- All 1800 rpm units will exercise at 1400 RPM
- All 3600 rpm units will exercise at 1800 RPM

If utility is lost during exercise the controller will do the following:

- Wait for the "line interrupt period" for utility to return. If utility returns within the "line interrupt period", continue to exercise at low RPM.

- If utility is still lost after the "line interrupt period", run the engine up to normal RPM and transfer the load. At this time the controller will exit the exercise routine and assume full automatic operation.

USER ADJUSTABLE SETTINGS

Setting	Factory Default	Minimum Setting	Maximum Setting	Increment
Exercise time	2 pm	00:00 (12 am)	23:59 (11:59 pm)	1 min
Exercise day	Wed	Sun	Sat	1 day
Current Time	12 am	00:00 (12 am)	23:59 (11:59 pm)	1 min
Current Day	Sun	Sun	Sat	1 day
Current Month	Jan	Jan	Dec	1 month
Current Year	2008	2008	2100	1 year
Language	English	French	Spanish	N/A
Contrast	80%	0%	100%	1%

FUEL CONVERSION

For fuel conversion steps, refer to the GenSpec section, RECONFIGURING THE FUEL SYSTEM.

OPERATION

This system is intended to supply standby power in the event of a utility failure. The control system will monitor the utility voltage to determine if stand-by power is required. Should the utility voltage fail, the generator will start and run normally, detaching from the utility and supplying the customer load from the generator. When utility power returns, the controller will re-transfer the customer load back to utility and shut down the generator.

AUTOMATIC TRANSFER OPERATION

To select automatic operation, do the following:

1. Make sure the transfer switch main contacts are set to their UTILITY position, i.e., loads connected to the utility power source.
2. Be sure that normal UTILITY power source voltage is available to transfer switch terminal lugs N1 and N2 (Refer to the Electrical Data section).
3. Set the generator's AUTO/OFF/MANUAL switch to AUTO.
4. Set the generator's main circuit breaker to its ON (or CLOSED) position.

With the preceding steps complete, the generator will start automatically when utility source voltage drops below a preset level. After the unit starts, loads are transferred to the standby power source. Refer to the Sequence of Automatic Operation section.

SEQUENCE OF AUTOMATIC OPERATION

Initial Conditions: Generator in Auto ready to run, load being supplied by the Utility Source through the transfer switch.

1. When the utility voltage fails (falls below 60% of nominal), a 10-30 second (programmable) "line interrupt" delay timer is started. The factory set time delay is 10 seconds. If at the end of the line interrupt time the utility voltage is above 60% the engine will not crank. If the utility voltage is still below the 60% of nominal at the end of the line interrupt time, the unit will crank and start. If the unit cranks for more than 10 seconds and the utility voltage rises above 80% of nominal (programmed pickup voltage) and the unit has not started, the crank cycle will abort.
2. As soon as the unit starts a 5 second "warm-up" timer is initiated. When the warm-up timer expires the control will transfer the load to the generator (through the RTS switch) if the utility voltage is less than 80% of nominal. If the utility voltage is greater than the 80% of nominal at the end of the warm-up time the load will not be transferred to the generator and a one minute low-speed cool down period will start. At the end of the one minute cool down period the generator will stop.
3. Once the unit is running and the switch has transferred the load to the generator the unit will monitor utility voltage. When utility voltage returns (above the programmable pickup voltage, normally 80% of nominal), a 15 second "Return to Utility" timer will start. At the end of the return to utility time, if the utility voltage is still above the pickup voltage, the unit will transfer the load back to the utility source and run the unit through a one minute cool down period. When the cool down period is over the unit will shut down and be ready for the next outage.
4. If during the cool down period utility voltage should fall below 60% of nominal the 5 second warm-up timer is initiated and the unit will transfer the load back to the generator and continue to monitor the utility.

CRANK CYCLES AND OVERCRANK SHUTDOWN

If the unit fails to start during a cranking period it will display the Overcrank Shutdown Alarm. The system will control the cranking cycles as follows:

The first crank cycle is a 16 second crank time followed by a 7 second rest. The next 5 cycles will be 7 seconds of cranking time each followed by a 7 second rest time.

If the unit fails to start by the end of the 6 crank/rest cycles the Overcrank Shutdown Alarm will display and the unit will not attempt to crank until the alarm is reset.

AUTO START

This unit is designed to automatically start in the event of a utility failure or brown out condition. Brown out is defined as utility voltage less than 60% nominal, while utility is considered good when it is restored to at least the pickup value, 80% of nominal. These levels are fixed. The "Line Interrupt period" is an adjustable parameter by the dealer. If 2-wire start mode is activated, the unit will start when 2-wire start is active.

MANUAL START

Allows the user to start and run the generator manually.

Transfer of the load to the generator will occur if utility is lost while the unit is running in the manual mode (only if activated).

ALARM AND WARNING MESSAGES

Alarms are defined as "Latching" which means they must be cleared before the alarm message on the screen will clear. They can be of type "Shutdown" or not and are logged in the alarm log. Alarms are all annunciated on the display).

Warnings are "Non Latching" meaning the message automatically clears when the warning condition goes away. Warnings can not be of type "Shutdown" but they are logged in the alarm log. Warnings are all annunciated on the display.

LOW OIL PRESSURE SHUTDOWN ALARM

There is a 10 second delay before oil pressure is monitored.

HIGH COOLANT TEMPERATURE SHUTDOWN ALARM

There is a 10 second delay before engine temperature is monitored.

Once running there is a 1/4 second delay before shut down. The limit is set at 125° C or 257° F.

OVERCRANK SHUTDOWN ALARM

Occurs if the engine has not started within the specified crank cycle.

OVERSPEED SHUTDOWN ALARM

Warning indicator is measured and calculated by the microprocessor. Overspeed is defined as +20% of nominal engine speed for 3 seconds, or +25% immediate.

Nominal engine speed = 60.0 Hz

RPM SENSOR FAILURE SHUTDOWN ALARM

During cranking: If the board does not see a valid RPM signal within four (4) seconds of cranking it will shut down and lock out on RPM sensor loss.

During running: If the RPM signal is lost for one full second the board will shut the engine down, wait 15 seconds, then re-crank the engine if in AUTO, it will not re-crank in MANUAL.

If no RPM signal is detected within the first four (4) seconds of cranking, the control board will shut the engine down and latch out on RPM sensor loss.

If the RPM signal is detected the engine will start and run normally. If the RPM signal is subsequently lost the control board will try two more re-cranks before latching out and flashing the RPM Sensor Failure message (if it is in AUTO).

Control Panel

Figure 1 – Generator Control Panel

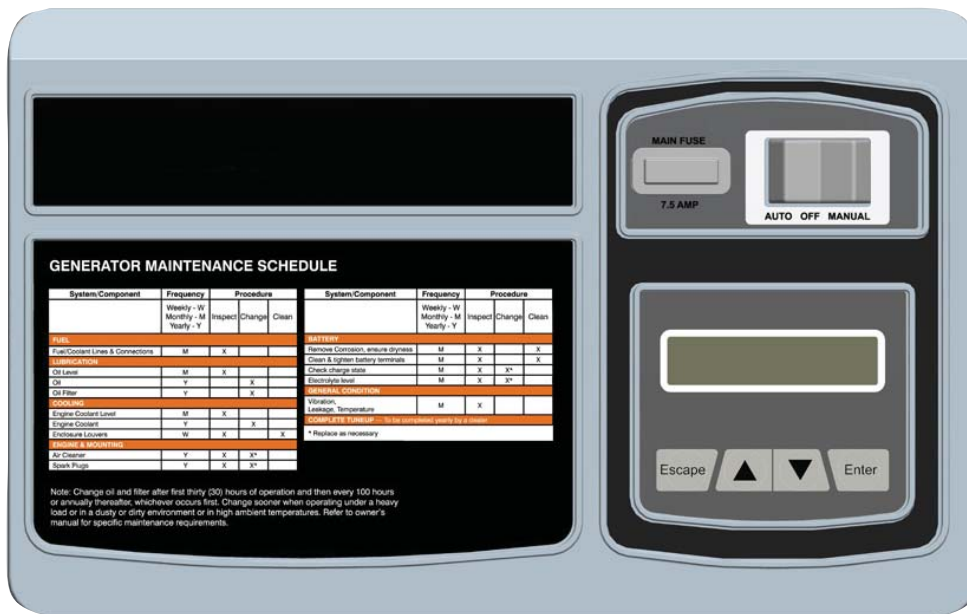

GENERATOR MAINTENANCE SCHEDULE

System/Component	Frequency			Procedure			System/Component	Frequency			Procedure		
	Weekly - W	Monthly - M	Yearly - Y	Inspect	Change	Clear		Weekly - W	Monthly - M	Yearly - Y	Inspect	Change	Clear
FILTER													
Exhaust/Control Lines & Connections	M	X					Replace	M	X				
LUBRICATION							Remove Corrosion, ensure dryness	M	X			X	
Oil Level	M	X					Clean & tighten battery terminals	M	X			X	
Oil	Y		X				Check charge state	M	X	X			
Oil Filter	Y		X				Electrolyte level	M	X	X			
WATERPUMP CONNECTIONS													
Waterpump	M	X					Waterpump	M	X				
Engine Coolant Level	M	X					Lockstep Temperature	M	X				
Engine Coolant	Y		X				* COMPLETE TUNEUP - To be completed yearly by a dealer						
Exhausture Louvers	W	X	X				* Replace as necessary						
REPAIRS & MAINTENANCE													
Air Cleaner	Y	X	X										
Spark Plugs	Y	X	X										

Note: Change oil and filter after first thirty (30) hours of operation and then every 100 hours or annually thereafter, whichever occurs first. Change sooner when operating under a heavy load or in a dusty or dirty environment or in high ambient temperatures. Refer to owner's manual for specific maintenance requirements.

CHECK ENGINE MESSAGE

The control system has detected an emissions related fault. This fault cannot be cleared using the control panel interface. The unit will continue to operate in automatic mode. Contact your local servicing dealer.

UNDER-FREQUENCY SHUTDOWN ALARM

After starting, if the generator stays under frequency for more than 30 seconds, it will shutdown.

LOW BATTERY ALARM

While running, if the average battery voltage falls below 11.9 volts for one (1) minute, the low battery alarm will be displayed.

LOW BATTERY WARNING

The microprocessor will continually monitor the battery voltage and display the Low Battery Voltage message if the battery voltage falls below 12.2 Volts for one (1) minute.

No other action is taken on a low battery warning condition. The warning will automatically clear if the battery voltage rises above 12.2 volts.

NOTE:

The battery sentinel is a separate feature that monitors battery condition.

LOW COOLANT LEVEL ALARM

This is a shutdown alarm. The sensor will be continuously monitored. If an error condition is seen for five (5) consecutive seconds, the alarm will be displayed.

MISSING CAM PULSE ALARM

This is a shutdown alarm. The alarm will activate after five (5) seconds of continuously missing cam pulses.

MISSING CRANK PULSE ALARM

This is a shutdown alarm. The alarm will activate after 12 consecutive revs where crank pulses are missing.

LOW FUEL PRESSURE WARNING

Fuel pressure is monitored by a digital sensor with a fixed setpoint of below five (5) inches water column.

GOVERNOR SENSOR FAULT ALARM

The governor position is monitored by an analog feedback signal. If the throttle position is seen outside of the normal operating range, a shutdown alarm is displayed. If the throttle is commanded to move, and no movement is seen, a shutdown alarm is displayed.

WIRING ERROR ALARM

When power is first applied to the controller, the software will perform a check on the wiring of the transfer output, and ensure it does not have high voltage on the wire. If this is the case, it will signal a miswire alarm and will not run. The test can be skipped by use of the escape key.

UNDERVOLTAGE ALARM

If the generator voltage falls below 60% for >5 seconds, an alarm will be issued.

Control Panel

OVERVOLTAGE ALARM

If the generator voltage rises above 110% for >3 seconds, an alarm will be issued.

If the generator voltage rises above 130% for >0.2 seconds, an alarm will be issued.

INTERNAL FAILURE SHUTDOWN ALARM

Any internal failure that can be detected such as corrupted firmware will cause this shutdown alarm. This alarm cannot be cleared.

CANBUS ALARM

Where applicable, if the Canbus communications link fails to communicate, a “Canbus Alarm” will be generated. This only applies to systems with external ignition modules. The alarm may be generated if:

1. The physical link is broken.
2. The Ignition Module fails or resets.
3. The Nexus Controller fails or resets.
4. Having the Battery Chargers 120 VAC connected without a battery installed.
5. A blown 10 amp Ignition Module fuse (approximately 12 inches away from the starter).
6. A blown 25 amp system fuse (located approximately 12 inches away from the DC alternator).

NOTE:

The “Canbus Alarm” will not clear on its own. To clear the alarm, press the “enter” key to acknowledge the alarm. The alarm will clear and if the fault is still present, the alarm will reoccur.

IGNITION ALARM

When an ignition alarm occurs, a generic message “Ignition Fault” will be displayed as the fault code.

MAINTENANCE WARNING

When a maintenance period expires, a warning message will be posted. The warning can be reset by hitting the Enter key. Resetting will clear the warning and reset the maintenance counters for the condition annunciated. The history log will reflect the maintenance warning.

ALARM CANCEL

When the generator is shut down due to a latching alarm, the Auto /Off/ Manual switch must be set to the off position and the ENTER key pressed to unlatch any active fault and clear the corresponding fault alarm message.

COMMON ALARM RELAY

The common alarm relay will be activated if there is a shutdown alarm. It will not activate on warnings or indicate that the Auto/Off/ Manual switch is in the OFF position. The OFF position will clear the alarms and the relay. The relay will not be used to indicate a generator is not activated.

The common alarm connections are wired to a set of potential-free (dry) contacts on the Nexus controller board. These Normally Open (N.O.) contacts close when an alarm condition occurs and are used to activate a remote signaling device. The circuit is rated for a maximum of 130mA at 24 VDC. The connections are a short set of free hanging wires that exit the engine harness loom directly behind the Nexus Control Panel and are labeled numbers 209 and 210.

MAINTENANCE ALERTS

Maintenance alerts will be provided for these conditions.

SERVICE SCHEDULE ‘A’

Inspect Accessory Drive Alert	1yr / 100hrs*
Coolant Change & Flush	1yr / 100hrs
Inspect Spark Plugs Alert	1yr / 100hrs
Change Oil & Filter Alert	1yr / 100hrs*
Inspect Battery Alert	1yr / 100hrs
Change / Inspect Air Filter Alert	1yr / 100hrs
Clean/Inspect Air Inlet & Exhaust	6mo / 50hrs*
* Items require a 3 month / 30 hour break-in change or check.	

SERVICE SCHEDULE ‘B’

Change / Inspect spark plugs alert	2yr/ 250hr
------------------------------------	------------

MENU SYSTEM

Control Panel

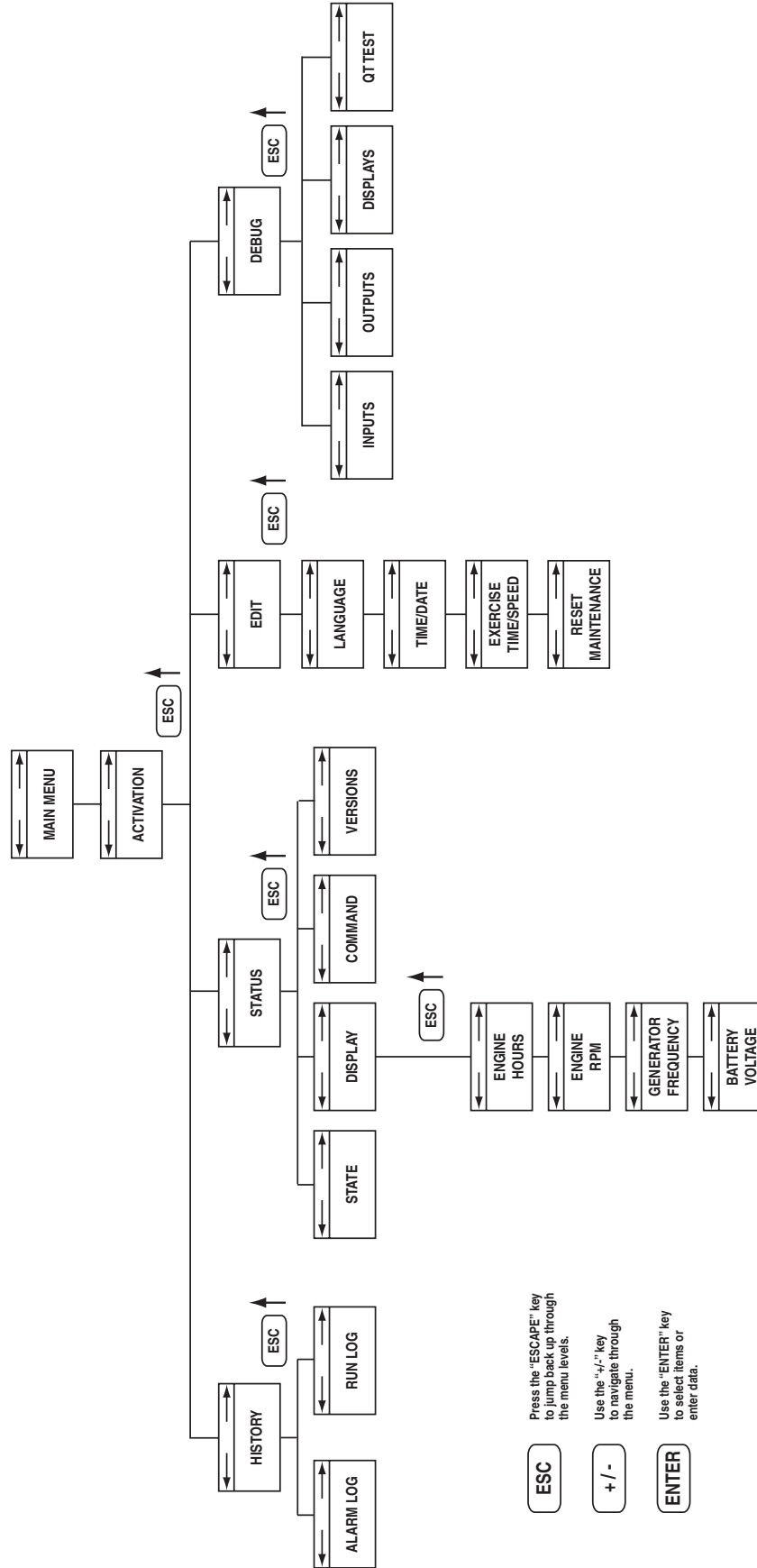

STATIONARY EMERGENCY GENERATOR CONTROL AND OPERATION

Refer to the appropriate control panel operator's manual for this unit.

OPERATING UNIT WITH MANUAL TRANSFER SWITCH

If the Stationary Emergency Generator was installed in conjunction with a transfer switch capable of manual operation only, the following procedure applies. A manually operated transfer switch is one that will not provide automatic start-up and does not include an intelligence circuit.

ENGINE START-UP AND TRANSFER

For additional information, refer to the applicable control panel manual for this unit, as well as any literature pertaining to the specific transfer switch.

⚠ DANGER!

⚠ The Maintenance Disconnect Switch and the AUTO/OFF/MANUAL switches (if so equipped) must be set properly, or the generator will crank and start as soon as the utility power to the transfer switch is turned off. Refer to applicable control panel and transfer switch manuals for more information.

⚠ Do not proceed until certain that utility source voltage is available to the transfer switch and the transfer switch main contacts are set to UTILITY.

⚠ Do not attempt manual operation until all power supplies to the transfer switch have been positively turned off, or extremely dangerous - possibly lethal - electrical shock will result.

⚠ Transfer switch enclosure doors should be kept closed and locked. Only authorized personnel should be allowed access to the transfer switch interior. Extremely high and dangerous voltages are present in the transfer switch.

In order to transfer load from the utility source to the generator, follow these directions:

- Turn OFF or disconnect the utility power circuit to the transfer switch, using the means provided (such as the utility source main line circuit breaker).
- Set the transfer handle to its UTILITY (NORMAL) position with load circuits connected to the utility power supply.
- Set the generator's main line circuit breaker to its OFF (or OPEN) position.
- Start the generator.

⚠ CAUTION!

⚠ Do not crank the engine continuously for longer than 30 seconds, or the heat may damage the starter motor.

- Let engine stabilize and warm up.
- Check all applicable instrument and gauge readings. When certain that all readings are correct, move the transfer switch manual handle to the STANDBY (or EMERGENCY STANDBY) position, i.e., load circuits supplied by the generator.
- Set the generator's main line circuit breaker to its ON (or CLOSED) position.
- Load circuits are now powered by the generator.

RETRANSFER AND SHUTDOWN

For additional information, refer to the applicable control panel manual for this unit, as well as any literature pertaining to the specific transfer switch.

To transfer the load back to the utility power source and shut down the generator, follow these directions:

- Set the generator's main line circuit breaker to its OFF (or OPEN) position.
- Manually move the transfer switch handle to its UTILITY (NORMAL) position, i.e., load circuits connected to the utility.
- Turn ON the utility power supply to the transfer switch, using the means provided (such as the utility power source main line circuit breaker).
- Let the generator run at no-load for a few minutes to stabilize internal temperatures.
- Shut down the generator.

OPERATING UNIT WITH AUTOMATIC TRANSFER SWITCH

If the Stationary Emergency Generator has been installed with an automatic transfer switch, the engine may be started and stopped automatically or manually.

NOTE:

Refer to the applicable manual for your transfer switch and to "Transfer Switch Start Signal Connections". In addition, please note the dangers under "Engine Start-up and Transfer."

GENERAL MAINTENANCE

⚠ WARNING!

⚠ Before working on the Stationary Emergency Generator, ensure the following:

- The AUTO/OFF/MANUAL switch is in the OFF position.
- The control panel fuse has been removed from the control box.
- The 120VAC supply to the battery charger is switched OFF.
- The negative battery cable has been removed.

CHECK ENGINE OIL

Check engine crankcase oil level (Figure 10.1) according to the Service Schedule and SIB10-10-L24G.

- Remove oil dipstick and wipe dry with a clean, lint-free cloth.
- Install oil dipstick, then remove again.
- Oil should be between FULL and ADD marks.
- If oil level is below the dipstick ADD mark, remove oil fill cap-. Add the recommended oil to bring oil level up to the FULL mark. DO NOT FILL ABOVE THE "FULL" MARK. See "Engine Oil Recommendations" for recommended oils.

Figure 10.1 - Oil Dipstick and Oil Fill Cap

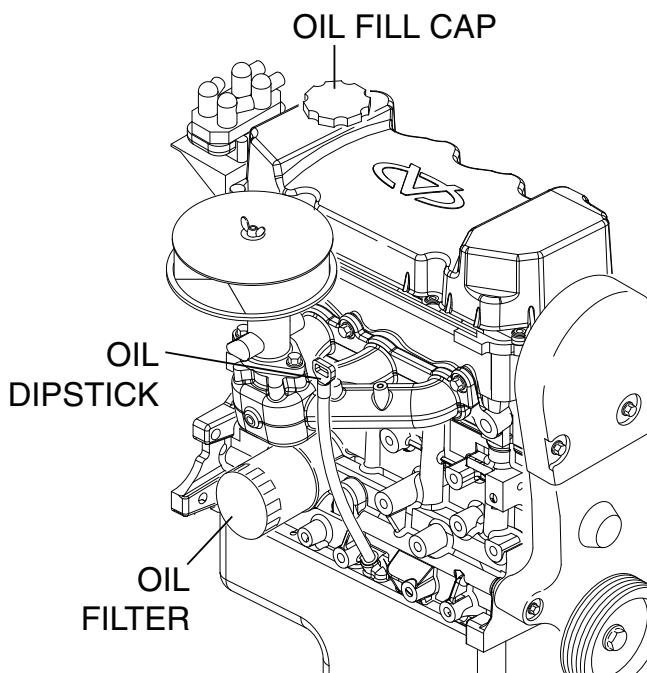

CHANGING ENGINE OIL

⚠ CAUTION!

⚠ Hot oil may cause burns. Allow engine to cool before draining oil. Avoid prolonged or repeated skin exposure with used oil. Thoroughly wash exposed areas with soap.

Refer to the Service Schedule for engine oil and filter change frequencies.

Drain the oil while the engine is still warm from running. This means warm up the engine, shut it down and drain immediately as follows:

1. Remove the drain hose from its retaining clip or cut the zip-tie securing the oil drain hose.
2. Loosen and remove OIL DRAIN HOSE CAP. Drain oil completely into suitable container.
3. When all oil has drained, install and tighten OIL DRAIN HOSE CAP and secure drain hose with a new zip-tie, or place the hose in its retaining clip.
4. Turn OIL FILTER (Figure 10.1) counterclockwise and remove. Properly dispose of old filter.
5. Apply light coating of new engine oil to seal of new oil filter. Install FILTER and tighten by hand only. DO NOT OVER TIGHTEN.
6. Remove OIL FILL CAP and add recommended oil. Crankcase oil capacity is listed in the "Specifications" section.

⚠ CAUTION!

⚠ After refilling the crankcase with oil, always check oil level on dipstick. NEVER OPERATE ENGINE WITH OIL BELOW THE DIPSTICK "ADD" MARK.

7. Start engine and check for oil leaks.
8. Shut OFF engine and wait 10 minutes for the oil to settle down into the oil pan. Recheck oil level on dipstick. DO NOT fill above the dipstick "FULL" mark.
9. Dispose of used oil at a proper collection center.

COOLING INTAKE/OUTLET

Air intake and outlet openings in the generator compartment must be open and unobstructed for continued proper operation. This includes such obstructions as high grass, weeds, brush, leaves and snow.

Without sufficient cooling and ventilating air flow, the engine/generator quickly overheats, which causes it to shut down. (See the installation diagram.)

⚠ WARNING!

⚠ The exhaust system parts from this product get extremely hot and remains hot after shutdown. High grass, weeds, brush, leaves, etc. must remain clear of the exhaust. Such materials may ignite and burn from the heat of the exhaust system.

INSPECT COOLING SYSTEM

- Inspect engine cooling system. See the Service Schedule.
- Check hoses for damage, deterioration, leaks, etc. Correct any discrepancies found.
- Check hose clamps for tightness.

ENGINE COOLANT

Check coolant level in coolant recovery bottle. See the Specifications and Service Schedule sections.

- Add recommended coolant mixture as necessary.
- Periodically remove radiator pressure cap (only when engine has cooled down) to make sure the coolant recovery system is functioning properly. Coolant should be at bottom of radiator filler neck. If coolant level is low, inspect gasket in radiator pressure cap. Replace cap, if necessary. To have pressure cap tested, contact a Service Facility. Inspect cooling system and coolant recovery system for leaks.

COOLANT CHANGE

Every year, have a service facility drain, flush and refill the cooling system. See the Specifications and Service Schedule for cooling system recommendations.

OVERLOAD PROTECTION FOR ENGINE DC ELECTRICAL SYSTEM

Engine cranking, start up and running are controlled by a solid state Engine Controller circuit board. Battery voltage is delivered to that circuit board via the control panel fuse. This overcurrent protection device will open if the circuit is overloaded.

⚠ CAUTION!

- ⚠ **If a circuit breaker opens or a fuse element melts, find the cause of the overload before resetting the circuit breaker or replacing the fuse.**

EXERCISE SYSTEM

Starts the Stationary Emergency Generator engine once every seven days and lets it run for 12 minutes.

PERFORM VISUAL INSPECTION

Complete a thorough visual inspection of the entire engine-generator monthly. Look for obvious damage, loose, missing or corroded nuts, bolts and other fasteners. Look for fuel, oil or coolant leaks.

INSPECT EXHAUST SYSTEM

Inspect the exhaust system at least once every year. Check all exhaust system pipes, mufflers, clamps, etc. for condition, tightness, leaks, security, damage.

CHECK FAN BELT

- Inspect fan belts every year. Replace any damaged, deteriorated, worn or otherwise defective belt.
- Check fan belt tension. Thumb pressure, exerted midway between pulleys, should deflect about 3/8 to 5/8 of an inch. Adjust belt tension as required.
- Check fan belt alignment (see Figure 10.2).

Figure 10.2 – Fan Belt

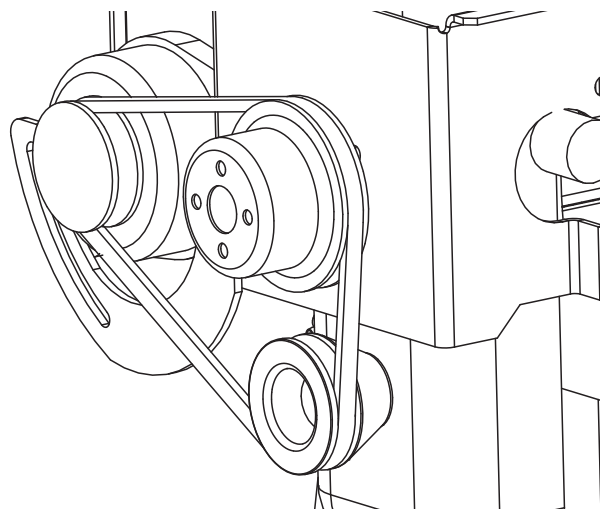

INSPECT ENGINE GOVERNOR

Visually inspect electronic governor.

⚠ DANGER!

- ⚠ **Do not attempt to adjust the governor. Only qualified service facilities should adjust the governor. Excessively high operating speeds are dangerous and increase the risk of personal injury. Low speeds impose a heavy load on the engine when adequate engine power is not available and may shorten engine life. Correct rated frequency and voltage are supplied only at the proper governed speed. Some connected electrical load devices may be damaged by incorrect frequency and/or voltage. Only qualified service technicians should adjust the governed speed.**

CHANGING THE ENGINE AIR FILTER

To replace the engine air filter, remove the air filter cover and replace the air filter making sure it is positioned properly before reattaching the cover (Figure 10.3).

See the Service Schedule for air filter maintenance.

Figure 10.3 – Engine Air Filter

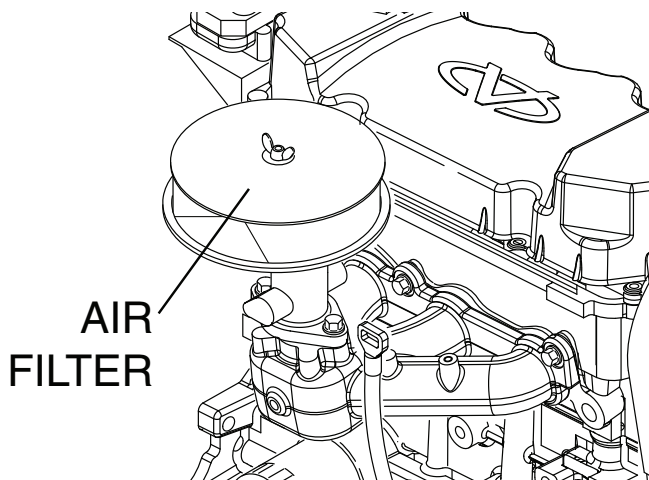

SPARK PLUGS

Reset the spark plug gap or replace the spark plugs as necessary.

1. Clean the area around the base of the spark plugs to keep dirt and debris out of the engine. Clean by scraping or washing using a wire brush and commercial solvent. Do not blast the spark plugs to clean.
2. Remove the spark plugs and check the condition. Replace the spark plugs if worn or if reuse is questionable. See the “Service Schedule” section for recommended inspection.
3. Check the spark plug gap using a wire feeler gauge. See the Specifications section for the required spark plug gap.

BATTERY MAINTENANCE

The battery should be inspected per the Service Schedule section. The following procedure should be followed for inspection:

1. Inspect the battery posts and cables for tightness and corrosion. Tighten and clean as necessary.
2. Check the battery fluid level of unsealed batteries and, if necessary, fill with DISTILLED WATER ONLY. DO NOT USE TAP WATER IN BATTERIES.
3. Have the state of charge and condition checked. This should be done with an automotive-type battery hydrometer.

⚠ DANGER!

⚠ Storage batteries give off explosive hydrogen gas. This gas can form an explosive mixture around the battery for several hours after charging. The slightest spark can ignite the gas and cause an explosion. Such an explosion can shatter the battery and cause blindness or other injury. Any area that houses a storage battery must be properly ventilated. Do not allow smoking, open flame, sparks or any spark producing tools or equipment near the battery.

⚠ Battery electrolyte fluid is an extremely corrosive sulfuric acid solution that can cause severe burns. Do not permit fluid to contact eyes, skin, clothing, painted surfaces, etc. Wear protective goggles, protective clothing and gloves when handling a battery. If fluid is spilled, flush the affected area immediately with clear water.

⚠ Do not use any jumper cables or booster battery to crank and start the generator engine. If the battery has completely discharged, remove it from the generator for recharging.

⚠ WARNING!

⚠ Be sure the AUTO/OFF/MANUAL switch is set to the OFF position, before connecting the battery cables. If the switch is set to AUTO or MANUAL, the generator can crank and start as soon as the battery cables are connected.

⚠ Be sure the 120VAC power supply to the battery is turned OFF, or sparking may occur at the battery posts as the cables are attached and cause an explosion.

BATTERY REPLACEMENT

NOTE:

Unit DOES NOT include battery.

When supplying or replacing the battery, the recommended number and type of battery is listed in the Specifications Section.

NOTE:

The BCI number should be located directly on the battery.

BATTERY FLUID

Check battery electrolyte fluid based on the Service Schedule. Fluid should cover separators in all battery cells. If fluid level is low, add distilled water to cover tops of separators. **DO NOT USE TAP WATER IN BATTERY.**

CLEANING THE STATIONARY EMERGENCY GENERATOR

Keep the generator as clean and as dry as possible. Dirt and moisture that accumulates on internal generator windings have an adverse effect on insulation resistance.

Periodically clean generator exterior surfaces. A soft brush may be used to loosen caked on dirt. Use a vacuum system or dry, low pressure air to remove any accumulations of dirt. The generator is housed inside an all-weather enclosure, clean the enclosure with a soft, damp cloth or sponge and water.

Once each year have the generator cleaned and inspected by a Service Dealer. That dealer will use dry, low pressure air to clean internal windings.

Finally, have the insulation resistance of stator and rotor windings checked. If insulation resistances are excessively low, the generator may require drying.

Service Schedule

SERVICE SCHEDULE

System / Component	Frequency	Procedure		
		Inspect	Change	Clean
	Weekly - W Monthly - M Yearly - Y			
Fuel				
Fuel Lines & Connections	M	X		
Lubrication				
Oil Level	M	X*		
Oil	Y		X**	
Oil Filter	Y		X**	
Cooling				
Engine Coolant Lines & Connections	M	X		
Engine Coolant Level	M	X		
Engine Coolant	Y		X	
Enclosure Louvers	W	X		X
Engine				
Air Cleaner	Y	X	X***	
Spark Plugs	Y	X	X***	
Battery				
Remove Corrosion, Ensure Dryness	M	X		X
Clean & Tighten Battery Terminals	M	X		X
Check Charge State	M	X	X***	
Check Electrolyte Level	M	X	X***	
General Condition				
Vibration, Noise, Leakage, Temperature	M	X		
Generator System				
Complete Tune-up and System Inspection	Y	To be completed by an Authorized Service Dealer.		
Footnotes				
* Inspect the oil level monthly or every 12 hours during continuous operation.				
** Change oil and oil filter after the first 30 hours of operation and then every 100 hours or annually thereafter, whichever occurs first. Change sooner when operating under heavy load or in a dusty or dirty environment or in high ambient temperatures.				
*** Replace as necessary.				

Troubleshooting

TROUBLESHOOTING GUIDE

PROBLEM	CAUSE	CORRECTION
Engine won't crank.	<ol style="list-style-type: none"> 1. Control panel 7.5 amp fuse blown. 2. Loose or corroded or defective battery cables. 3. Defective starter contactor. 4. Defective starter motor. 5. Dead or Defective Battery. 	<ol style="list-style-type: none"> 1. Replace fuse.* 2. Tighten, clean or replace battery cables as necessary.* 3. Replace contactor.* 4. Replace starter motor.* 5. Remove, change or replace battery.*
Engine cranks but won't start.	<ol style="list-style-type: none"> 1. Out of fuel. 2. Fuel solenoid (FS) is defective 3. Spark plugs defective. 	<ol style="list-style-type: none"> 1. Replenish fuel/turn on fuel valve. 2. Replace solenoid.* 3. Clean, regap or replace plugs.
Engine starts hard, runs rough.	<ol style="list-style-type: none"> 1. Air cleaner plugged or damaged. 2. Defective spark plugs. 3. Fuel pressure incorrect. 4. Insufficient fuel supply. 5. Fuel system set to wrong fuel type. 	<ol style="list-style-type: none"> 1. Clean or replace as needed. 2. Clean, regap or replace plugs. 3. Confirm fuel pressure to regulator is as recommended in SPECIFICATIONS.* 4. Confirm fuel pressure to regualtor is as recommended in SPECIFICATIONS.* 5. Reconfigure the fuel system. (See RECONFIGURING THE FUEL SYSTEM in manual.*
Engine starts then shuts down.	<ol style="list-style-type: none"> 1. Engine oil level is low. 2. Engine is overheated. 3. Defective Low Oil Pressure Switch 4. Defective Coolant Temperature Switch 5. Defective Control Module circuit board. 6. Coolant Level is Low. 7. Defective Low Coolant Level Switch 	<ol style="list-style-type: none"> 1. Check oil and add oil as needed. 2. Check cooling system for leaks. 3. Replace switch.* 4. Replace switch.* 5. Replace board.* 6. Repair leak - Add coolant. 7. Replace Switch.*
AUTO/OFF/MANUAL Switch at OFF, engine continues to run.	<ol style="list-style-type: none"> 1. Defective AUTO/OFF/MANUAL switch 2. Defective Control Module circuit board 	<ol style="list-style-type: none"> 1. Replace board.* 2. Replace board.*
No AC output from generator.	<ol style="list-style-type: none"> 1. Main line circuit breaker is tripped/open. 2. Generator internal failure. 3. Thermal circuit breaker open. 	<ol style="list-style-type: none"> 1. Reset to ON/CLOSED. 2. * 3. Auto-reset - Wait 5 min. and attempt restart.

***Contact the nearest Dealer for assistance.**

Warranty

United States Environmental Protection Agency Warranty Statement (Stationary Emergency Spark-Ignited Generators)

Warranty Rights, Obligations and Coverage

The United States Environmental Protection Agency (EPA) and Generac Power Systems, Inc. (Generac) are pleased to explain the Emission Control System Warranty on your new stationary emergency engine. If during the warranty period, any emission control system or component on your engine is found defective in materials or workmanship, Generac will repair your engine at no cost to you for diagnosis, replacement parts and labor provided it be done by a Generac Authorized Warranty Service Facility. Your emission control system may include parts such as the fuel metering, ignition, and exhaust systems and other related emission related components listed below. Generac will warrant the emissions control systems on your 2009 and later model year engines provided there has been no abuse, neglect, unapproved modification or improper maintenance of your engine. For engines less than 130 HP the warranty period is two years from the date of sale to the ultimate purchaser. For engines greater than or equal to 130 HP the warranty period is three years from the date of the engine being placed into service.

Purchaser's/Owner's Warranty Responsibilities

As the engine purchaser/owner you are responsible for the following. 1.) The engine must be installed and configured in accordance to the Generac's installation specifications. 2.) The completion of all maintenance requirements listed in your Owner's Manual. 3.) Any engine setting adjustment must be done in accordance and consistent with the instructions in the Owner's Manual. 4.) Any emission control system or component must be maintained and operated appropriately in order to ensure proper operation of the engine and control system to minimize emissions at all times.

Generac may deny any/or all Emission Control System Warranty coverage or responsibility of the engine, or an emission control system or component on your engine thereof, if it has failed due to abuse, neglect, unapproved modification or improper maintenance, or the use of counterfeit and/or 'gray market' parts not made, supplied or approved by Generac. Warranty service can be arranged by contacting either your selling dealer or a Generac Authorized Warranty Service dealer, 1-800-333-1322 for the dealer nearest you. The purchaser/owner shall be responsible for any expenses or other charges incurred for service calls and/or transportation of the product to/from the inspection or repair facilities. The purchaser/owner shall be responsible for any and/or all damages or losses incurred while the engine is being transported/shipped for inspection or warranty repairs. Contact Generac Power Systems Inc. for additional Emission Control System Warranty related information, Generac Power Systems, Inc. P.O. Box 8, Waukesha, WI 53187, or call 1-800-333-1322 or www.generac.com.

Important Note

This warranty statement explains your rights and obligations under the Emission Control System Warranty, which is provided to you by Generac pursuant to federal law. Note that this warranty shall not apply to any incidental, consequential or indirect damages caused by defects in materials or workmanship or any delay in repair or replacement of the defective part(s). This warranty is in place of all other warranties, expressed or implied. Specifically, Generac makes no other warranties as to the merchantability or fitness for a particular purpose. Any implied warranties which are allowed by law, shall be limited in duration to the terms of the express warranty provided herein. Some states do not allow limitations on how long an implied warranty lasts, so the above limitation may not apply to you.

Emission Related Parts Include the Following (if so equipped)

- | | |
|---|---|
| 1) Fuel Metering System | 3) Ignition System Including |
| 1.1) Gasoline Carburetor Assembly And Internal Components A) Fuel Filter, B) Carburetor, C) Fuel Pump | A) Spark Plug, B) Ignition Module, C) Ignition Coil, D) Spark Plug Wires |
| 1.2) Carburetion Assembly And Its Components A) Fuel Controller, B) Carburetor And Its Gaskets, C) Mixer And It Gaskets, D) Primary Gas Regulator E) Liquid Vaporizer | 4) Exhaust System A) Catalyst Assembly, B) Exhaust Manifold, C) Muffler, D) Exhaust Pipe, E) Muffler Gasket |
| 1.3) Fuel Regulator | 5) Crankcase Breather Assembly Including A) Breather Connection Tube, B) Pcv Valve |
| 2) Air Induction System Including A) Intake Pipe/Manifold, B) Air Cleaner | 6) Oxygen Sensor |
| | 7) Diagnostic Emission-Control System |

Warranty

United States Environmental Protection Agency Compliance Requirements (Stationary Emergency Spark-Ignited Generators)

Purchaser's/Owner's Recordkeeping Responsibilities

The United States Environmental Protection Agency (EPA) and Generac Power Systems, Inc. (Generac) are pleased to explain your record-keeping requirements for compliance with Subpart JJJJ- Standards of Performance for Stationary Spark Ignition Internal Combustion Engines as listed in the Electronic Code of Federal Regulations Title 40 Part 60. As the engine purchaser/owner who operates and maintains their certified emergency stationary engine and emission control system according to applicable emission related guidelines as specified in this Owner's Manual, you are required to meet the following notification and recordkeeping requirements to demonstrate compliance. 1.) Maintain documentation that the engine is certified to meet emission standards. 2.) Recordkeeping of maintenance conducted. 3.) Recordkeeping of the provision allowing natural gas engines to operate using propane for a maximum of 100 hours per year as an alternate fuel solely during emergency operations provided the engine is not certified to operate on propane. 4.) Meet all compliance notifications submitted to the purchaser/owner and maintain all supporting documentation. 5.) Recordkeeping of hours of operation, including what classified the operation as emergency and how many hours are spent for non-emergency operation. For emergency engines greater than or equal to 130 HP, recordkeeping of hours of operation begins January 1, 2011. For emergency engines less than 130 HP, recordkeeping of hours of operation begins January 1, 2009; Engines are equipped with non-resettable hour meters to facilitate recordkeeping.

Specific Air Quality Management or Air Pollution Control Districts may have different and additional record keeping/reporting requirements. Your permit to construct and/or operate the engine may be contingent upon compliance with those requirements. Check with your local Air Quality Management or Air Pollution Control District for specific requirements.

Emergency stationary internal combustion engines (ICE) may be operated for the purpose of maintenance checks and readiness testing, provided that the tests are recommended by Federal, State or local government, Generac, or the insurance company associated with the engine. Maintenance checks and readiness testing of such units is limited to 100 hours per year. There is no time limit on the use of emergency stationary ICE in emergency situations. The purchaser/owner may petition the Administrator for approval of additional hours to be used for maintenance checks and readiness testing, but a petition is not required if the owner maintains records indicating that Federal, State, or local standards require maintenance and testing of emergency ICE beyond 100 hours per year. Emergency stationary ICE may operate up to 50 hours per year in non emergency situations, but those 50 hours are counted towards the 100 hours per year provided for maintenance and testing.

The 50 hours per year for non-emergency situations cannot be used for peak shaving or to generate income for a facility to supply power to an electric grid or otherwise supply power as part of a financial arrangement with another entity. For purchaser/owner of emergency engines, any operation other than emergency operation, maintenance and testing, and operation in non-emergency situations for 50 hours per year, as permitted in this section is prohibited.

If you operate and maintain your certified emergency stationary SI internal combustion engine and emissions control systems in accordance to the specifications and guidelines in this Owner's Manual EPA will not require engine performance testing. If not, your engine will be considered non-certified and you must demonstrate compliance according to Subpart JJJJ - Standards of Performance for Stationary Spark Ignition Internal Combustion Engines as listed in the Electronic Code of Federal Regulations Title 40 Part 60.

Emission-Related Installation Instructions

Your certified emergency stationary engine has pre-set emission control systems or components that require no adjustment. Inspection and replacement of an emissions related component is required to be done so in accordance with the requirements cited in the United States Environmental Protection Agency Warranty Statement or can be arranged by contacting either your selling dealer or a Generac Authorized Warranty Service dealer, 1-800-333-1322 for the dealer nearest you. Failing to follow these instructions when installing a certified engine in a piece of nonroad equipment violates federal law 40 CFR 1068.105 (b), subject to fines or penalties as described in the Clean Air Act.

GROUP A

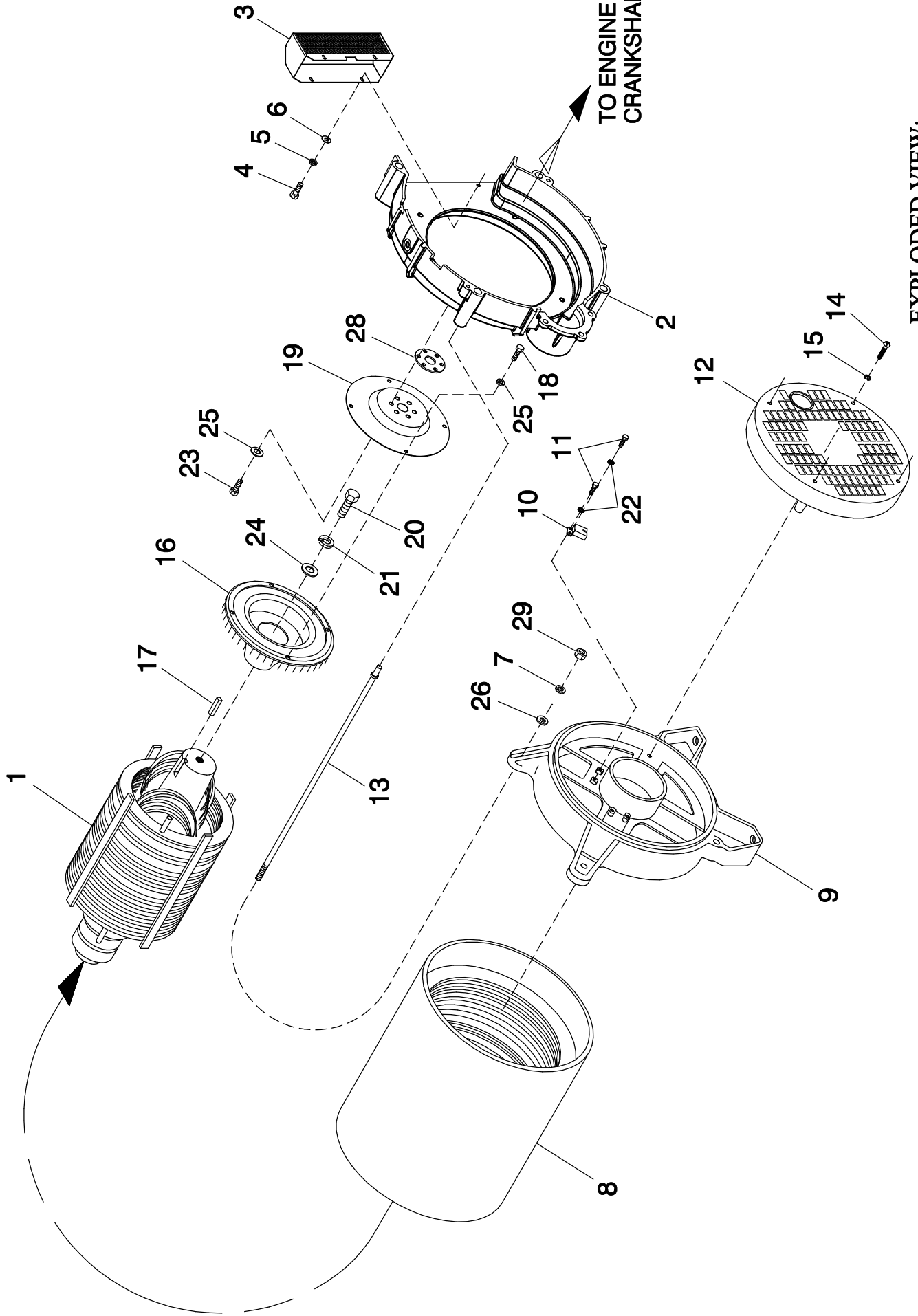

EXPLODED VIEW:
ALT COMMON PARTS 18KW, 20KW, 25KW, & 30KW
DRAWING #: 0G4008

EXPLODED VIEW: ALT COMMON PARTS 18KW, 20KW, 25KW, & 30KW

DRAWING #: 0G4008

GROUP A

APPLICABLE TO:

ITEM	PART #	QTY.	DESCRIPTION
1	0G4827	1	ASSY RTR 104 KD1 HI EFF (18KW)
	0G2927	1	RTR-102-20.0AD1 CPL (2006) (20KW)
	0G2827	1	ASSY RTR 25KW 2P (2006) (25KW)
	0G3451	1	ASSY RTR 30KW 2P 10" (2006)
2	0G0820A	1	HOUSING BLOWER L G PILOT
3	0G4452	1	BLOWER HOUSING SCREEN
4	020746	4	SCREW PPHM M5-0.8 X 8 ZINC
5	049226	4	WASHER LOCK M5
6	051713	4	WASHER FLAT M5
7	022129	4	WASHER LOCK M8-5/16
8	0G4825	1	ASSY STR 104-18AD1 HI EFF (18 KW)
	0G4826	1	ASSY STR 104 18GD1 HI EFF (18 KW)
	0G2926	1	STR-102-20.0AD1 CPL (2006) (20 KW)
	0G3682	1	STR-102-20.0GD1 CPL (2006) (20KW)
	0G5584	1	STR-102-20.0JD1 CPL (2006) (20 KW)
	0G3685	1	STR-102-20.0KD1 CPL (2006) (20KW)
	0G2826	1	ASSY STR 102 25AD1 (2006) (25KW)
	0G3683	1	STR-102-25.0GD1 CPL (2006) (25KW)
	0G6573	1	STR-102-25.0JD1 CPL (2006) (25KW)
	0G3686	1	STR-102-25.0KD1 CPL (2006) (25KW)
	0G3684	1	STR-102-30.0GD2 CPL (30KW)
	0G3687	1	STR-102-30.0KD2 CPL (30KW)
	0G5909	1	ASSY STR 102 30AD2 10" (30KW)
	0G6103	1	STR-102-30.0JD2
9	0A5382A	1	BEARING CARRIER REAR L G PILOT
10	075591	1	ASSY HOLDER BRUSH
11	051787	4	SCREW HHC M4-0.7 X 16 G8.8
12	0A5601A	1	COVER REAR BEARING
13	0G8827	4	STUD M8-1.25 475 LONG
	0G8827A	4	STUD M8-1.25 418 LONG
14	0A9375	4	SCREW RHM #10-24 X 2
15	022152	4	WASHER LOCK #10
16	0G4196	1	FLYWHEEL & RINGGEAR ASSY 1.6L
17	042558	1	KEY SQ 3/8 X 1 STEEL
18	051756	4	SCREW HHC M10-1.5 X 20 C8.8
19	0G0965B	1	PLATE FLEX 1.6L R12.7
20	053607	1	SCREW HHC M12-1.75 X 35 G8.8
21	051769	1	WASHER LOCK M12
22	023365	4	WASHER SHAKEPROOF INT #8
(1) 23	0F3353	6	SCREW HHC M10-1.0 X 20 G10.9
24	072578	1	SPACER ROTOR SHAFT
25	0G3787	10	WASHER .41 ID .94 OD .12 THK
26	0A8830	4	WASHER FLAT .34 ID X .75 OD
27	077043E	1	FLEX CONDUIT 1" BLACK (NOT SHOWN)
28	0G2070	1	PLATE SPACER 14GA 1.6L (TO BE USED WITH ENGINE PLATE P/N 0G0834.)
	0G2070A	1	PLATE SPACER 16GA 1.6L (TO BE USED WITH ENGINE PLATE P/N 0G0834A.)
29	045771	4	NUT HEX M8-1.25 G8 CLEAR ZINC

(1) APPLY LOCTITE 242 BEFORE THREADING SCREW INTO CRANKSHAFT.

225 AF

GROUP A

C1 DPE BREAKER SELECTION		
MODEL RATING	ITEM 7 RATING	ITEM 7 P/N
22KW/27KW - 10	3A	054502
30KW - 10	4.5A	048476
25KW/30KW - 30	5.5A	054450
22KW/27KW - 30	6A	048505
22KW/27KW - 10 50Hz	5A	048512
25KW - 10	4.0A	049350

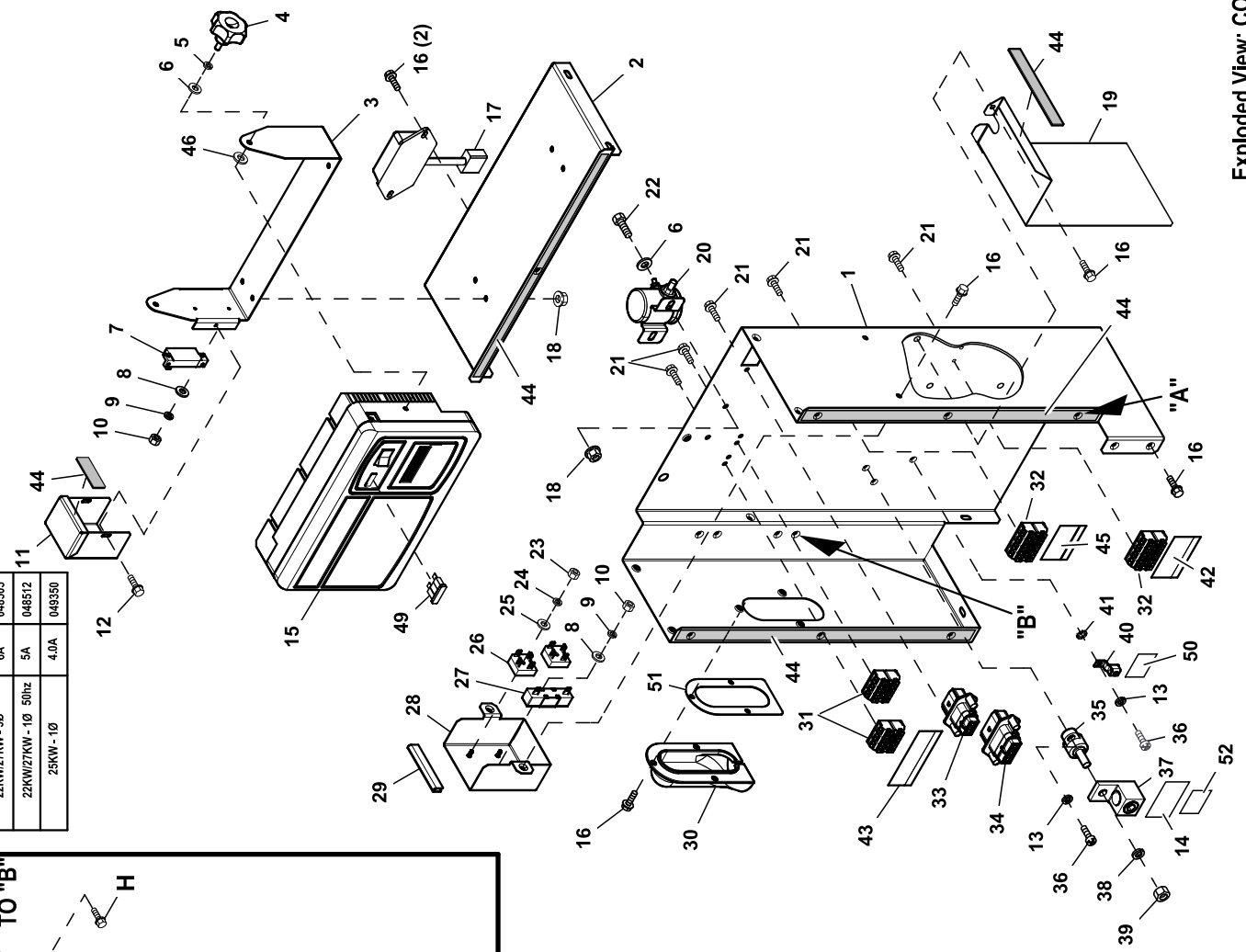
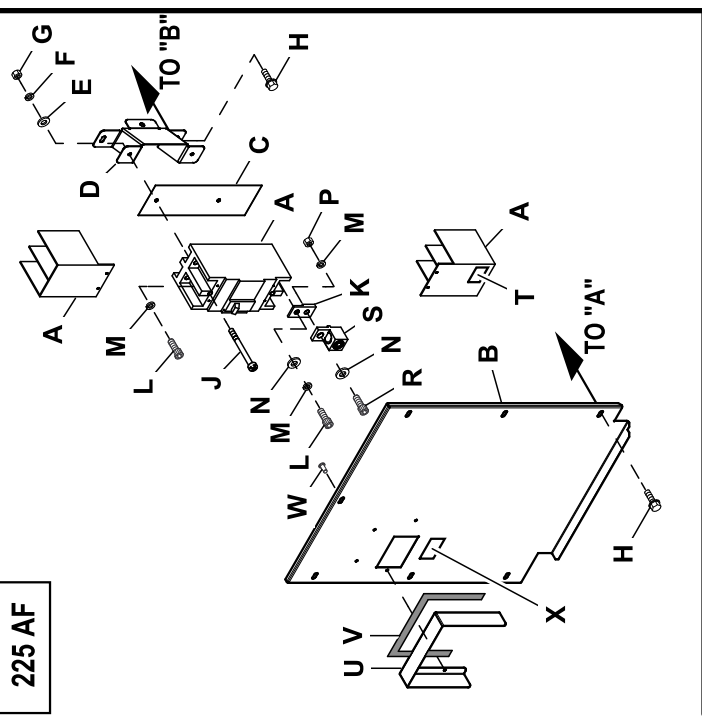

GROUP A

CC (2P)

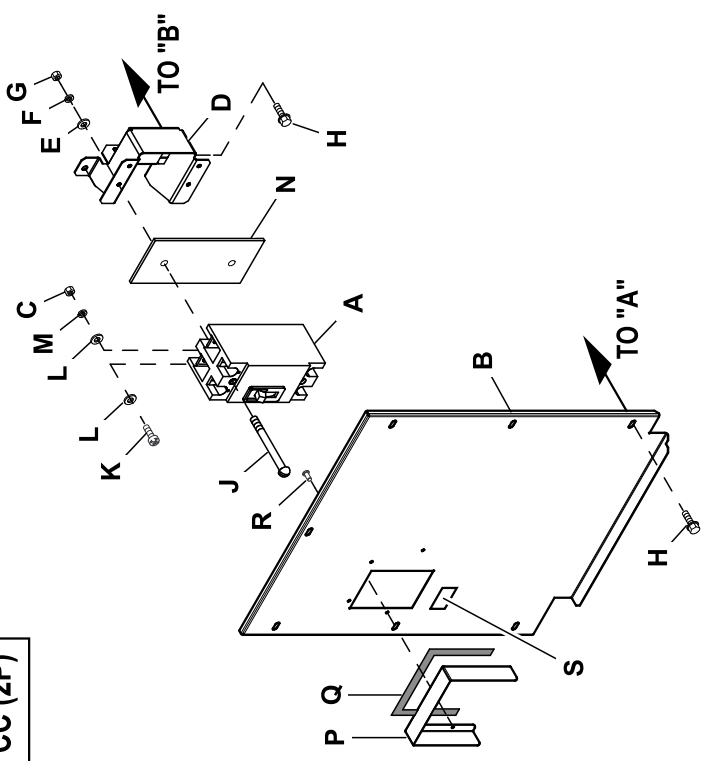

CC/FG (3P)

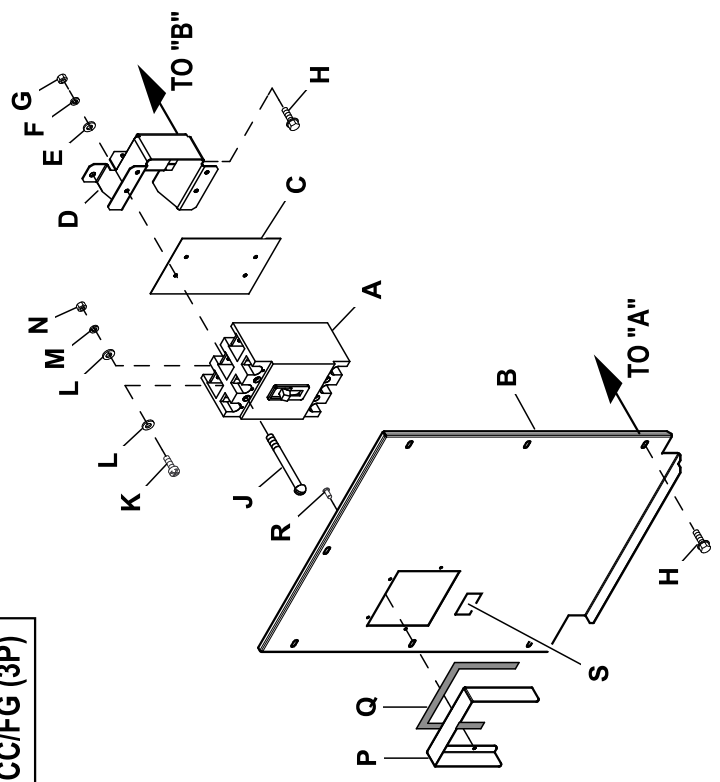

GROUP A

ED (3P)

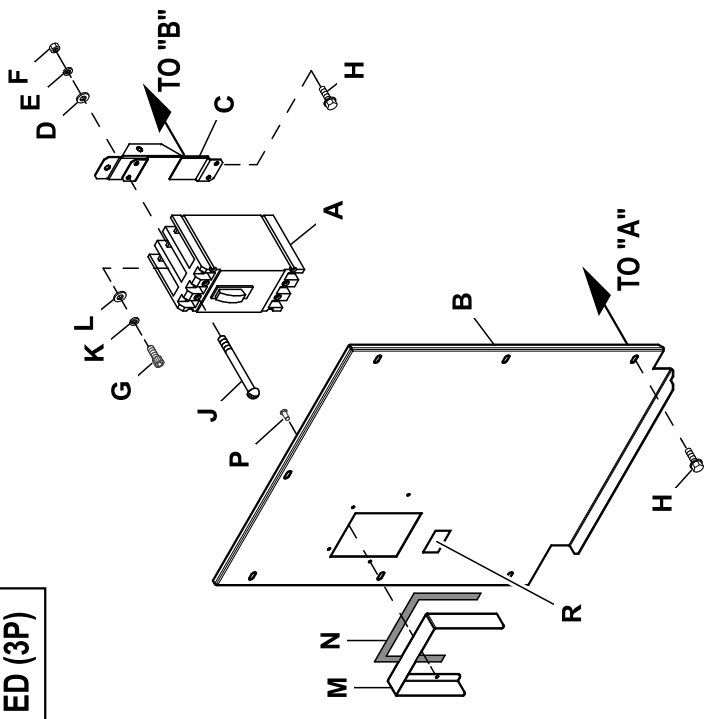

QN2

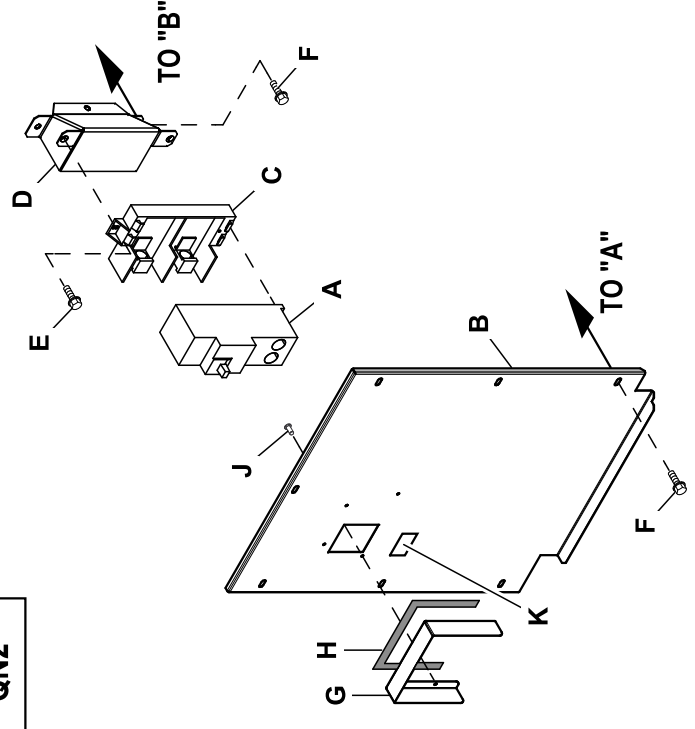

BQ (2P)

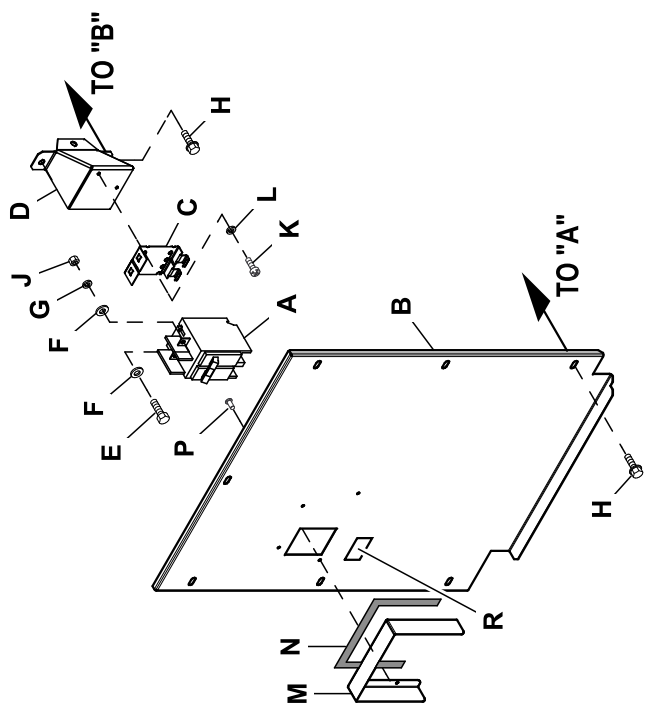

BQ (3P)

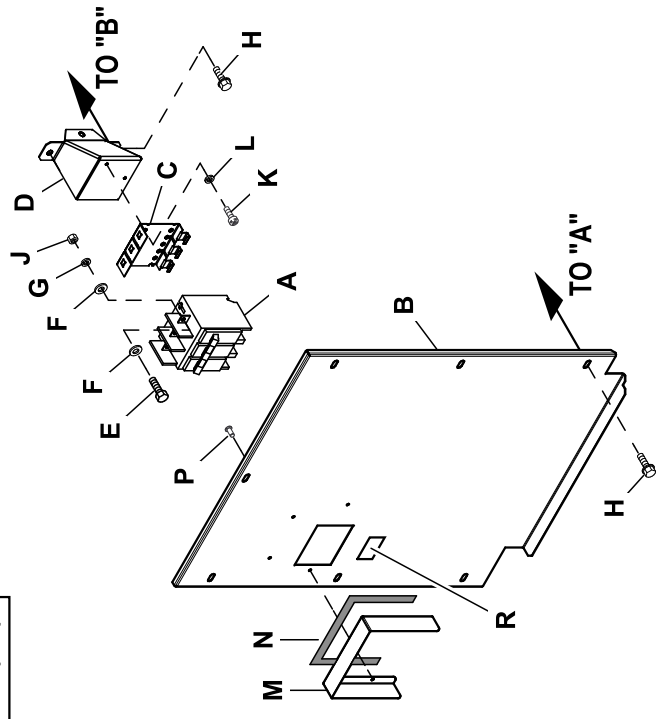

EXPLODED VIEW: CONNECTION BOX C1 CPL

DRAWING #: 0H7234

GROUP A

APPLICABLE TO:

ITEM	PART#	QTY.	DESCRIPTION
1	0H6795	1	CONBOX BACK/SIDES C1 CPL
2	0H6796	1	CONBOX TOP C1 CPL
(4)3	0H67330STOR	1	BRACKET GIMBAL CONTROL PNL RAW
4	0H7115	2	KNOB M6-1.0 CONTROL PANEL
5	022097	2	WASHER LOCK M6-1/4
6	022473	4	WASHER FLAT 1/4-M6 ZINC
(3)7	SEE CHART	1	CIRCUIT BREAKER
8	052777	3	WASHER FLAT M3
9	043182	3	WASHER LOCK M3
10	051714	3	NUT HEX M3-0.5 G8 CLEAR ZINC
(4)11	0H81040AS0R	1	COVER DPE BREAKER NEXUS
12	045764	2	SCREW HHTT M4-0.7 X 8 ZP
13	022264	3	WASHER LOCK #8-M4
14	0A9457	1	DECAL NEUTRAL
15	REF	1	ASSY CTRL PROGRAMMED
16	0C2454	18	SCREW HWHT M6-1 X 16 N WA Z/JS
(2)17	0A1354A	1	REGULATOR - DC ALT
18	0D3700	6	NUT FLANGE M6-1.0 NYLON
(4)19	0H88380STOR	1	SHIELD HIGH/LOW C1 RAW
20	056739	1	RELAY SOLENOID 12VDC PNL MNT
21	0F5458	12	SCREW HHSP #10 X 3/8 HI-LOW
22	042568	2	SCREW HHC M6-1.0 X 20 C8.8
23	051716	2	NUT HEX M5-0.8 G8 CLEAR ZINC
24	049226	2	WASHER LOCK M5
25	051713	2	WASHER FLAT M5
26	0D7177V	2	DIODE BRIDGE 1P 35A 1000V
27	0F5752F	1	RES WW 15R 5% 25W QK CONN
28	0H6267	1	COVER VOLTAGE SHIELD
29	056326	1	TRIM VINYL BLACK 1/8GP (3"LG)
30	0G3524	1	COVER BELL HOUSING CONBOX
(1)31	0D7393T	REF	TERM BLOCK 3P UL 12-20AWG
(1)32	0D7393U	REF	TERM BLOCK 4P UL 12-20AWG
(1)33	0F5376S0AR	REF	MX150L SLRRMNT 22-18 8P W/O GA
(1)34	0F5396S0AR	REF	MX150L SLRRMNT 22-18 12P W/OGA
35	057073	1	JUNCTION BLOCK 3/8-16
36	0C2265	3	SCREW PHTT M4-0.7 X 12 ZP
37	057329	1	LUG SLDLSS 350-#6X13/32 AL/CU
38	022237	1	WASHER LOCK 3/8
39	022241	1	NUT HEX 3/8-16 STEEL
40	025433	1	LUG SLDLSS #6-14 X 13/64 CU
41	023762	1	WASHER LOCK EXT #10 STL
42	0H7292	1	DECAL CUSTOMER CONTROL CONNECT
43	0H7293	1	DECAL CONBOX TB1 CONNECTIONS
44	029289	1	TAPE ELEC 1/2 FOAM (62" LG)
45	0J0489	1	DECAL CUSTOMER POWER CONNECT
46	0A2115	2	WASHER NYLON .257
47	0F6146	1	HANG TAG 2 WIRE START (NOT SHOWN)
48	0H6692	1	HARN CONBOX NEXUS (NOT SHOWN)
49	0D7178T	REF	FUSE ATO TYPE 7.5AMP (BROWN)
50	067210A	1	DECAL GROUND LUG
51	0J6701	1	GASKET WIRE ENTRY COVER
52	0H8006	1	DECAL CAUTION ELEC SHOCK SM

UL CIRCUIT BREAKER (225AF)

A	0G5249	REF	CB 150A 2 POLE 240V 225AF
B	0H6846	1	COVER CB G 225AF C1 CONBOX
C	0F8432A	1	INSULATOR CB 2P 225AF
D	0G5734	1	SPRT CIRCUIT BREAKER G 225AF
E	038150	2	WASHER FLAT #8 ZINC
F	022264	2	WASHER LOCK #8-M4
G	022471	2	NUT HEX #8-32 STEEL
H	0C2454	10	SCREW HWHT M6-1 X 16 N WA Z/JS
J	053640	2	SCREW RHM #8-32 X 3-1/4
K	0F8843	2	BUS BAR 200A LUG ADAPTOR
L	049897	4	SCREW SHC M8-1.25 X 20 G8

EXPLODED VIEW: CONNECTION BOX C1 CPL

DRAWING #: 0H7234

GROUP A

APPLICABLE TO:

ITEM	PART#	QTY.	DESCRIPTION
M	022129	6	WASHER LOCK M8-5/16
N	022145	4	WASHER FLAT 5/16-M8 ZINC
P	045771	2	NUT HEX M8-1.25 G8 CLEAR ZINC
R	058306	2	SCREW SHC M8-1.25 X 25 C12.9
S	0F8451	2	LUG SLDLSS 300 MCM-6 AL/CU
T	0G3259	1	DECAL TERMINAL SHOCK HZD BI
U	0J78230ASOR	1	SHIELD CB HANDLE CONBOX
V	029289	1	TAPE ELEC 1/2 FOAM
W	036261	4	RIVET POP .125 X .275 SS
X	0K4772	1	DECAL SERVICE DISCONNECT

(1) ITEMS INCLUDED WITH HARNESS P/N 0H6692.

(2) ITEMS USED ON 1.6L MODELS ONLY.

(3) SEE "C1 DPE BREAKER SELECTION" TABLE.

(4) SHEET METAL PARTS LISTED IN THE BOM TABLE ARE REPRESENTING GENERIC PARTS (NO COLOR)

- MANUFACTURING: FOR CORRECT MATERIAL AND COLOR REFER TO AS400 BOM.
- CUSTOMER: WHEN ORDERING REPLACEMENT PARTS ENTER BASE NUMBER (FIRST 6 DIGITS ONLY) IN THE SYSTEM FOR CORRECT MATERIAL AND COLOR (FOR REFERENCE SEE GUIDELINE 0H7169).

EXPLODED VIEW: CONNECTION BOX C1 CPL

DRAWING #: 0H7234

GROUP A

APPLICABLE TO:

ITEM	PART#	QTY.	DESCRIPTION
UL CIRCUIT BREAKER (CC 2P)			
A	0H4745	REF	CB 0100A 2P 240V E CC LL
	0H4746	REF	CB 0125A 2P 240V E CC LL
	0H4747	REF	CB 0150A 2P 240V E CC LL
B	0H6847	1	COVER CB E CC 2P C1 CONBOX
C	051716	2	NUT HEX M5-0.8 G8 CLEAR ZINC
D	0H4656	1	CIRCUIT BREAKER SUPPORT (CC)
E	038150	2	WASHER FLAT #8 ZINC
F	022264	2	WASHER LOCK #8-M4
G	022471	2	NUT HEX #8-32 STEEL
H	0C2454	10	SCREW HWHT M6-1 X 16 N WA Z/JS
J	053640	2	SCREW RHM #8-32 X 3-1/4
K	091526	2	SCREW PPHM M5-0.8 X 12 ZNC
L	023897	4	WASHER FLAT #10 ZINC
M	049226	2	WASHER LOCK M5
N	0H4698	1	INSULATOR CB 2P E TYPE CC
P	0J78230AS0R	1	SHIELD CB HANDLE CONBOX
Q	029289	1	TAPE ELEC 1/2 FOAM
R	036261	4	RIVET POP .125 X .275 SS
S	0K4772	1	DECAL SERVICE DISCONNECT
UL CIRCUIT BREAKER (CC/FG (3P))			
A	0H4913	REF	CB 0100 3P 240V E CC LL
	0H4914	REF	CB 0125 3P 240V E CC LL
	0H5488	REF	CB 0080 3P 600V E FG LL
	0H5489	REF	CB 0090 3P 600V E FG LL
B	0H7294	1	CB COVER E CC/FG 3P C1 CONBOX
C	0H4698A	1	INSULATOR CB 3P E TYPE CC/FG
D	0H4656	REF	CIRCUIT BREAKER SUPPORT (CC)
	0H5604	REF	CIRCUIT BREAKER SUPPORT (FG)
E	038150	4	WASHER FLAT #8 ZINC
F	022264	4	WASHER LOCK #8-M4
G	022471	4	NUT HEX #8-32 STEEL
H	0C2454	10	SCREW HWHT M6-1 X 16 N WA Z/JS
J	053640	4	SCREW RHM #8-32 X 3-1/4 (CC)
	0H5721	4	SCREW PPHM #8-32 X 1-3/4 ZINC (FG)
K	091526	3	SCREW PPHM M5-0.8 X 12 ZNC
L	023897	6	WASHER FLAT #10 ZINC
M	049226	3	WASHER LOCK M5
N	051716	3	NUT HEX M5-0.8 G8 CLEAR ZINC
P	0J78230AS0R	1	SHIELD CB HANDLE CONBOX
Q	029289	1	TAPE ELEC 1/2 FOAM
R	036261	4	RIVET POP .125 X .275 SS
S	0K4772	1	DECAL SERVICE DISCONNECT

EXPLODED VIEW: CONNECTION BOX C1 CPL

DRAWING #: 0H7234

GROUP A

APPLICABLE TO:

ITEM	PART#	QTY.	DESCRIPTION
UL CIRCUIT BREAKER (BQ 2P)			
A	0D5543	REF	CB 0090A 2P 240V S BQ2 LL
	0D5544	REF	CB 0100A 2P 240V S BQ2 LL
	0A2077	REF	CB 0125A 2P 240V S BQ2 LL
B	0H6842	1	COVER CB S BQ2 C1 CONBOX
C	0E7890	1	BRKT CB MTG BACK
D	0G4497	1	CIRCUIT BREAKER SUPPORT (BQ)
E	052619	2	SCREW HHC M5-0.8 X 20 G8.8
F	023897	4	WASHER FLAT #10 ZINC
G	049226	2	WASHER LOCK M5
H	0C2454	10	SCREW HWHT M6-1 X 16 N WA Z/JS
J	051716	2	NUT HEX M5-0.8 G8 CLEAR ZINC
K	0G9708	2	SCREW PHTT M4-0.7 X 8 ZP
L	022264	2	WASHER LOCK #8-M4
M	0J78230ASOR	1	SHIELD CB HANDLE CONBOX
N	029289	1	TAPE ELEC 1/2 FOAM
P	036261	4	RIVET POP .125 X .275 SS
R	0K4772	1	DECAL SERVICE DISCONNECT
UL CIRCUIT BREAKER (BQ 3P)			
A	062812	REF	CB 0080A 3P 240V S BQ3 LL
	053691	REF	CIRCT BRK 90 X 3 ITE BQ3-B090
	040532	REF	CB 0100A 3P 240V S BQ3 LL
B	0H6843	1	COVER CB S BQ3 C1 CONBOX
C	0E6002	1	MTG TRACK BQ SIEMENS CB 3P
D	0G4497	1	CIRCUIT BREAKER SUPPORT (BQ)
E	052619	3	SCREW HHC M5-0.8 X 20 G8.8
F	023897	6	WASHER FLAT #10 ZINC
G	049226	3	WASHER LOCK M5
H	0C2454	10	SCREW HWHT M6-1 X 16 N WA Z/JS
J	051716	3	NUT HEX M5-0.8 G8 CLEAR ZINC
K	0G9708	2	SCREW PHTT M4-0.7 X 8 ZP
L	022264	2	WASHER LOCK #8-M4
M	0J78230ASOR	1	SHIELD CB HANDLE CONBOX
N	029289	1	TAPE ELEC 1/2 FOAM
P	036261	4	RIVET POP .125 X .275 SS
R	0K4772	1	DECAL SERVICE DISCONNECT
UL CIRCUIT BREAKER (ED 3P)			
A	0D5552	REF	CB 0050A 3P 480V S ED4 LL
	0D5556	REF	CB 0090A 3P 480V S ED4 LL
	0D5557	REF	CB 0100A 3P 480V S ED4 LL
	0D9693	REF	CB 0125A 3P 480V S ED4 LL
B	0H6844	1	COVER CB S ED3 C1 CONBOX
C	0G4498	1	CIRCUIT BREAKER SUPPORT (ED)
D	038150	4	WASHER FLAT #8 ZINC
E	022264	4	WASHER LOCK #8-M4
F	022471	4	NUT HEX #8-32 STEEL
G	0A8278	3	SCREW SHC 1/4-28 X 3/4 G8.8 NZ
H	0C2454	10	SCREW HWHT M6-1 X 16 N WA Z/JS
J	066715	4	SCREW RHM #8-32 X 4-1/2
K	022097	3	WASHER LOCK M6-1/4
L	0D5621	3	WASHER-STEP 1/2ODX9/32ID BRASS
M	0J78230ASOR	1	SHIELD CB HANDLE CONBOX
N	029289	1	TAPE ELEC 1/2 FOAM
P	036261	4	RIVET POP .125 X .275 SS
R	0K4772	1	DECAL SERVICE DISCONNECT
UL CIRCUIT BREAKER (QN2 2P)			
A	0E7283	REF	CB 0150A 2P 240V S QN2 LL
B	0H6845	1	COVER CB S QN2 C1 CONBOX
C	0E3664	1	BASE, QN CIRCUIT BREAKER
D	0G4112	1	BREAKER SUPPORT BRACKET 30KW
E	074908	2	SCREW HHTT M5-0.8 X 10 BP
F	0C2454	10	SCREW HWHT M6-1 X 16 N WA Z/JS

EXPLODED VIEW: CONNECTION BOX C1 CPL

DRAWING #: 0H7234

APPLICABLE TO:

GROUP A

ITEM	PART#	QTY.	DESCRIPTION
G	0J78230AS0R	1	SHIELD CB HANDLE CONBOX
H	029289	1	TAPE ELEC 1/2 FOAM
J	036261	4	RIVET POP .125 X .2
K	0K4772	1	DECAL SERVICE DISCONNECT

GROUP C

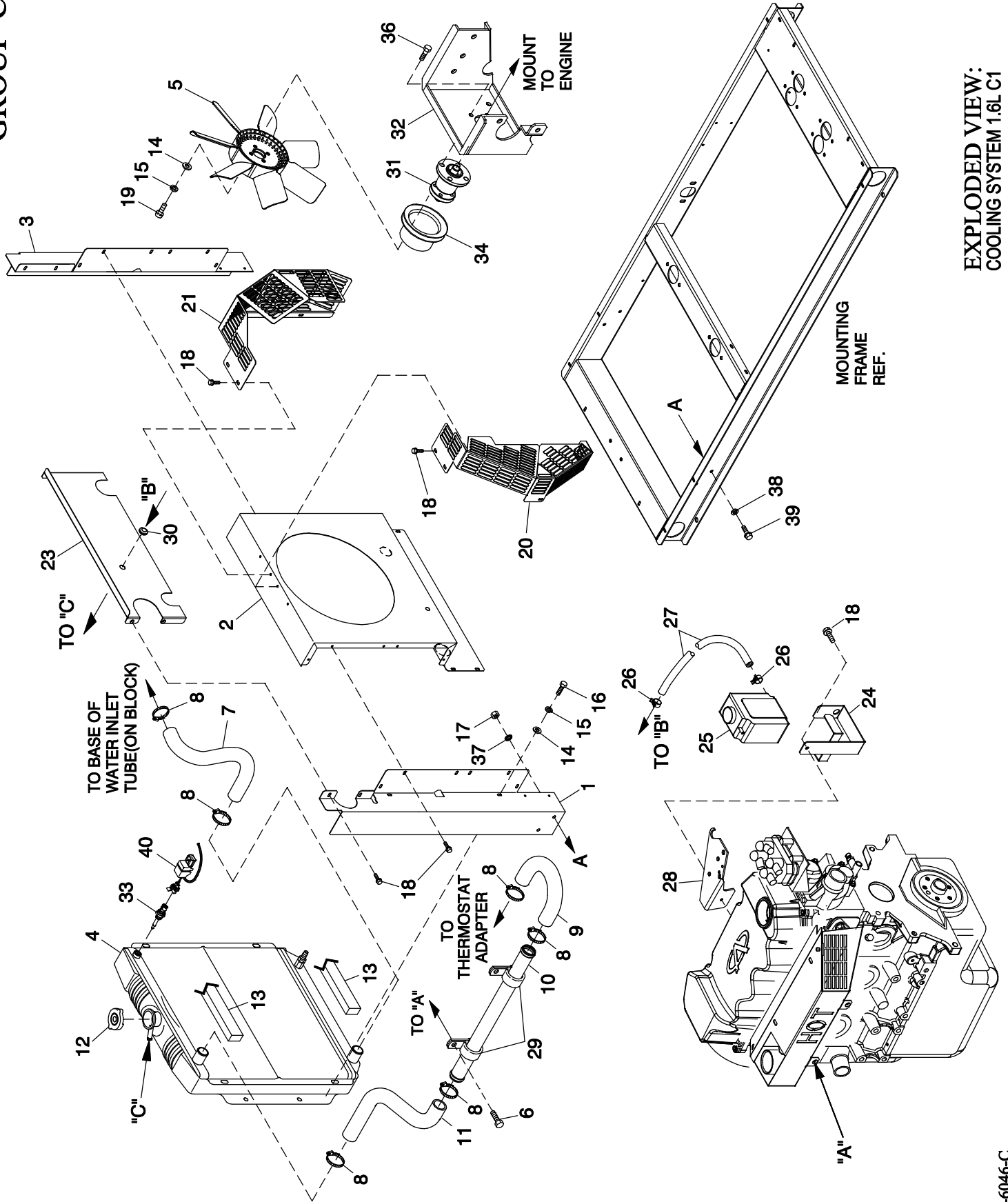

EXPLODED VIEW:
 COOLING SYSTEM 1.6L C1
 DRAWING #: 0G3428

EXPLODED VIEW: COOLING SYSTEM 1.6L C1

DRAWING #: 0G3428

GROUP C

APPLICABLE TO:

ITEM	PART #	QTY.	DESCRIPTION
1	0G3418	1	RADIATOR SUPPORT LH SIDE 1.6L
2	0G3421	1	VENTURI 1.6L
3	0G3419	1	RADIATOR SUPPORT RH SIDE 1.6L
4	0E9837B	1	RADIATOR 1.6L CHY
5	0G3553	1	FAN COOL 450MM DIA 7 BLADE
6	0E3257	2	SCREW HWHTF M6-1.0 X 16
7	0G4080	1	HOSE LOWER RADIATOR 1.6L
8	099502	6	CLAMP HOSE #24 B1.06-2.00
9	0G4070	1	HOSE REAR COOLANT 1.6L
10	0G4072	1	TUBE ENGINE COOLANT 1.6L
11	0G4071	1	HOSE UPPER RADIATOR 1.6L
12	046627	1	CAP RADIATOR
13	052250	2	TAPE FOAM 1 X 1 (24" LG)
14	022473	8	WASHER FLAT 1/4-M6 ZINC
15	022097	8	WASHER LOCK M6-1/4
16	0C8566	4	SCREW HHFC M6-1.0 X 20 G8.8
17	045771	4	NUT HEX M8-1.25 G8 CLEAR ZINC
18	0C2454A	28	SCREW THF M6-1 X 12 N WA Z/J
19	042568	4	SCREW HHC M6-1.0 X 20 G8.8
20	0G3573	1	GUARD FAN LH C1
21	0G3574	1	GUARD FAN RH C1
23	0G3420	1	RADIATOR BLOCK-OFF
24	080713	1	BRACKET COOLANT TANK
25	076749	1	TANK COOLANT RECOVERY
26	048031C	2	CLAMP HOSE BAND 1/4
27	029032	1	HOSE 9/32 ID (43" LG)
28	0G4451	REF	BRACKET STEPPER MOTOR COOLANT
29	055934N	2	CLAMP VINYL 1.31 X .281 Z
30	0F9504	1	GROMMET 5/8"X 1 1/8"X 5/16"
31	0G0568	1	ASSY FAN BEARING SUPPORT
32	0G3433	1	BRACKET FAN ALT ADAPTER 1.6L
33	0E2507	1	PROBE COOLANT LEVEL 3/8NPTF
	0H1827	1	PROBE COOLANT LEVEL 3/8-18NPTF (USE WITH I/N 40, P/N 0H1851)
34	0A2628	1	PULLEY - FAN 95 DIA
35	029333A	10	TIE WRAP UL 7.4" X .19" BLK (NOT SHOWN)
(1) 36	042907	4	SCREW HHC M8-1.25 X 16 G8.8
37	027482	4	WASHER SHAKEPROOF EXT 5/16 STL
38	022129	4	WASHER LOCK M8-5/16
39	039253	4	SCREW HHC M8-1.25 X 20 G8.8
(2) 40	0H1851	1	ASSY PCB LCL SENSOR (USE WITH I/N 33, P/N 0H1827 ONLY)

(1) APPLY LOCTITE 242 TO I/N 36 BEFORE THREADING INTO I/N 31.

(2) USE WITH R-200 CONTROL PANEL ONLY.

GROUP C

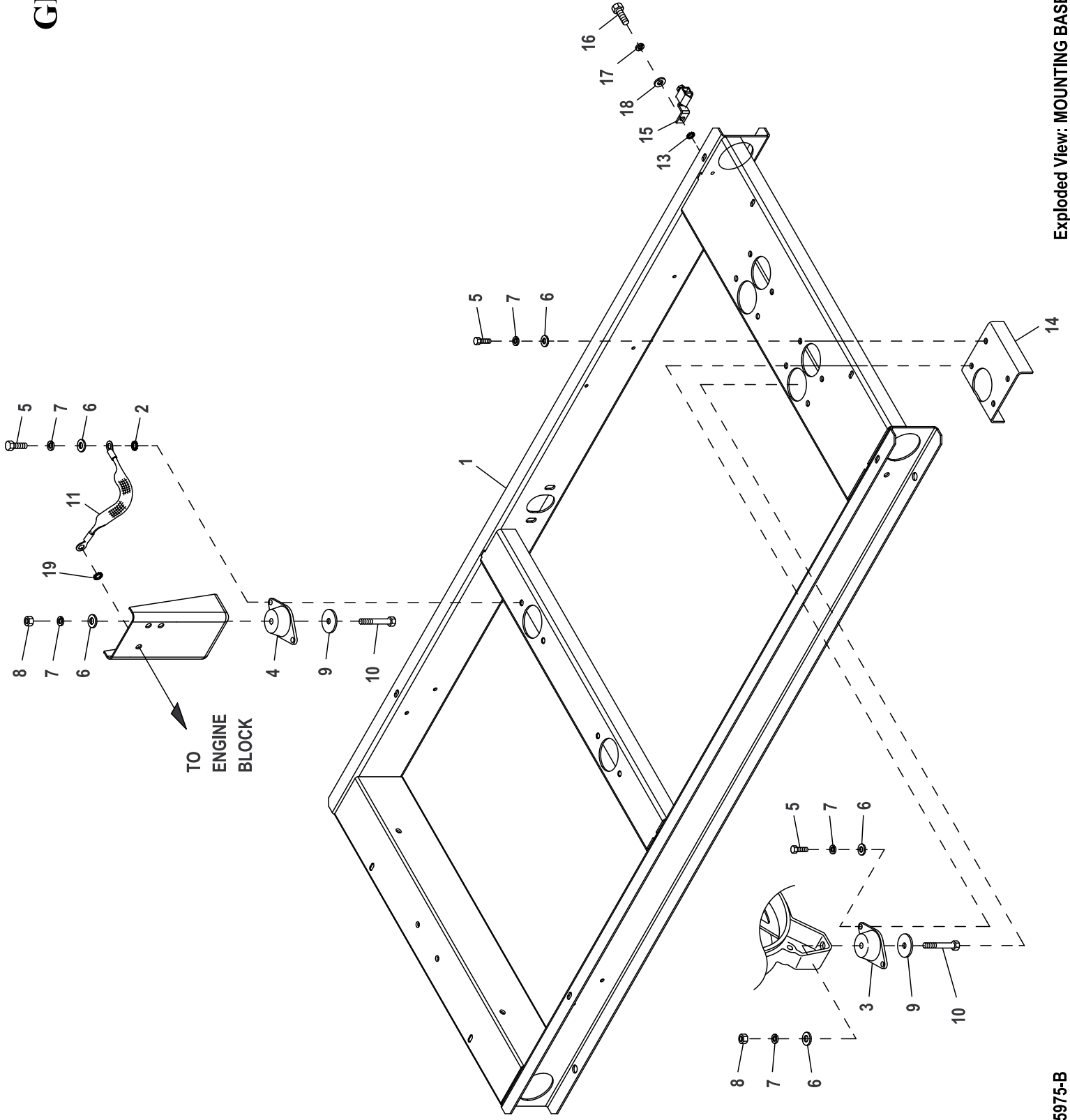

Exploded View: MOUNTING BASE 1.6L
Drawing No.: 0G3531

EXPLODED VIEW: MOUNTING BASE 1.6L**DRAWING #: 0G3531****GROUP C****APPLICABLE TO:**

ITEM	PART#	QTY.	DESCRIPTION
1	0G3343	1	MOUNTING BASE 1.6L 2007 C1
2	027482	1	WASHER SHAKEPROOF EXT 5/16 STL
3	070936	2	DAMPENER VIBRATION
4	070936C	2	VIB. ISO. 70-75 DURO
5	039253	12	SCREW HHC M8-1.25 X 20 G8.8
6	022145	16	WASHER FLAT 5/16 ZINC
7	022129	16	WASHER LOCK M8-5/16
8	045771	4	NUT HEX M8-1.25 G8 YEL CHR
9	071956	4	WASHER FLAT M8
10	051730	4	SCREW HHC M8-1.25 X 60 G8.8
11	021991	1	EARTH STRAP
13	026850	1	WASHER SHAKEPROOF EXT 1/4 STL
14	0G3461	2	ALTERNATOR SUPPORT BLOCK OFF
15	055414	1	LUG SLDLSS #2-#8 X 17/64 CU
16	047411	1	SCREW HHC M6-1.0 X 16 G8.8
17	022097	1	WASHER LOCK M6-1/4
18	022473	5	WASHER FLAT 1/4-M6 ZINC
19	025507	1	WASHER LOCK EXT 7/16 STL

GROUP C

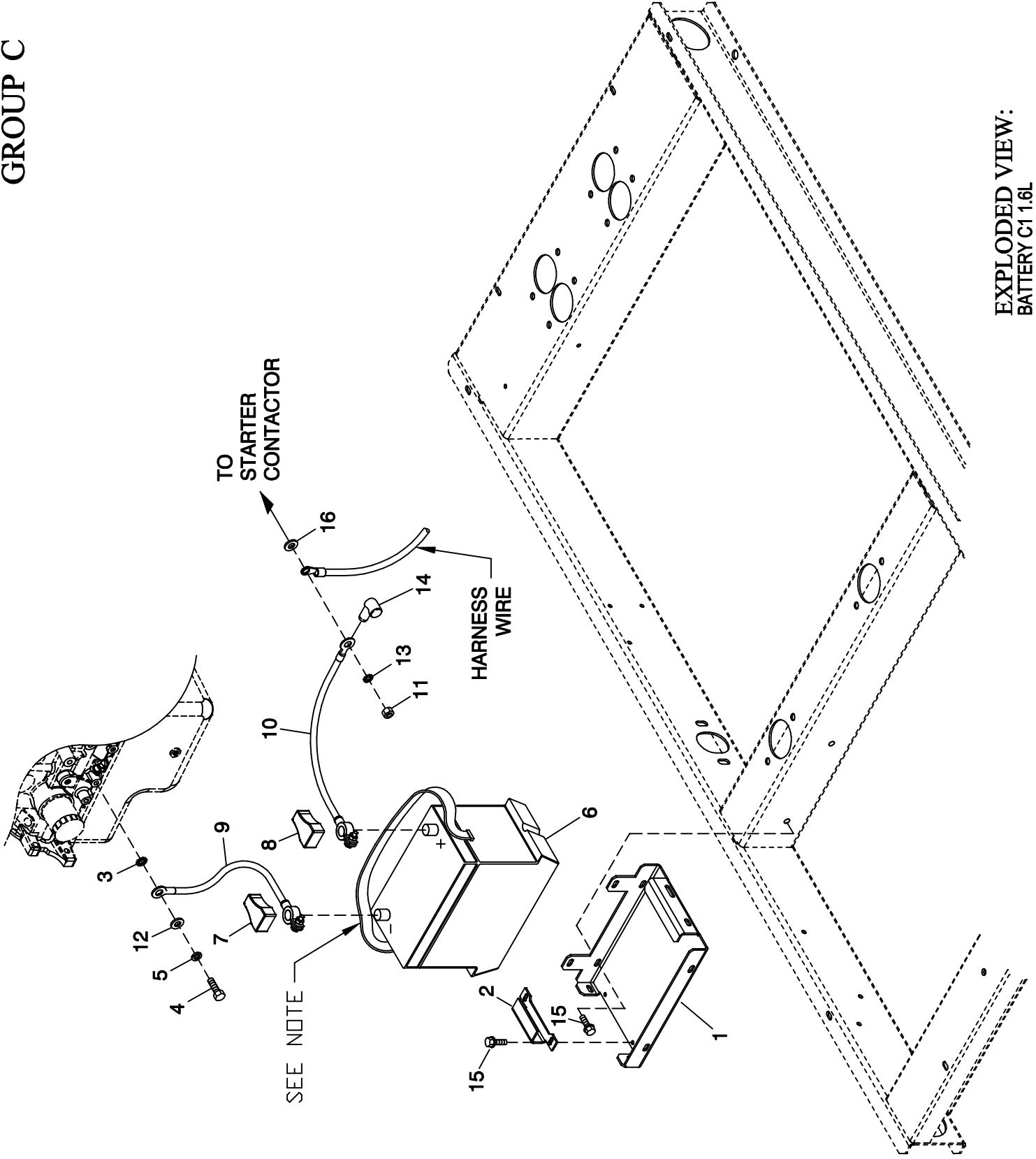

EXPLODED VIEW:
BATTERY C1 1.6L
DRAWING #: 0G4067

EXPLODED VIEW: BATTERY C1 1.6L**DRAWING #: 0G4067****GROUP C**

APPLICABLE TO:

ITEM	PART #	QTY.	DESCRIPTION
1	0F3408C	1	BATTERY TRAY, C1 & C2
2	0F3411	1	STRAP BATTERY RETAINMENT
3	025507	1	WASHER SHAKEPROOF EXT 7/16 STL
4	059980	1	SCREW HHC M10-1.5 X 25 G10.9
5	046526	1	WASHER LOCK M10
6	077483	REF	BATTERY 12VDC 75-AH 26
7	050331A	REF	BATTERY POST COVER RED +
8	050331	REF	BATTERY POST COVER BLK -
9	038805J	1	CABLE BATTERY BLACK #1 X 30.00
10	038804M	1	CABLE BATTERY RED #1 X 21.00
11	045771	REF	NUT HEX M8-1.25 G8 YEL CHR
12	022131	1	WASHER FLAT 3/8-M10 ZINC
13	027482	1	WASHER SHAKEPROOF EXT 5/16 STL
14	0F3976	1	BOOT CONTACTOR CABLES
15	0C2454	4	SCREW THF M6-1 X 16 N WA Z/JS
16	022145	REF	WASHER FLAT 5/16-M8 ZINC

NOTE: WHEN INSTALLING BATTERY, TUCK BATTERY'S LIFTING STRAP ALONG THE LEFT SIDE OF BATTERY (SIDE OPPOSITE RADIATOR) BEFORE CONNECTING THE BATTERY CABLES.

GROUP D

		TORQUE POUND-FEET (KPM)	
IN	QTY		
20	7	45 (6)	
28	4	45 (6)	

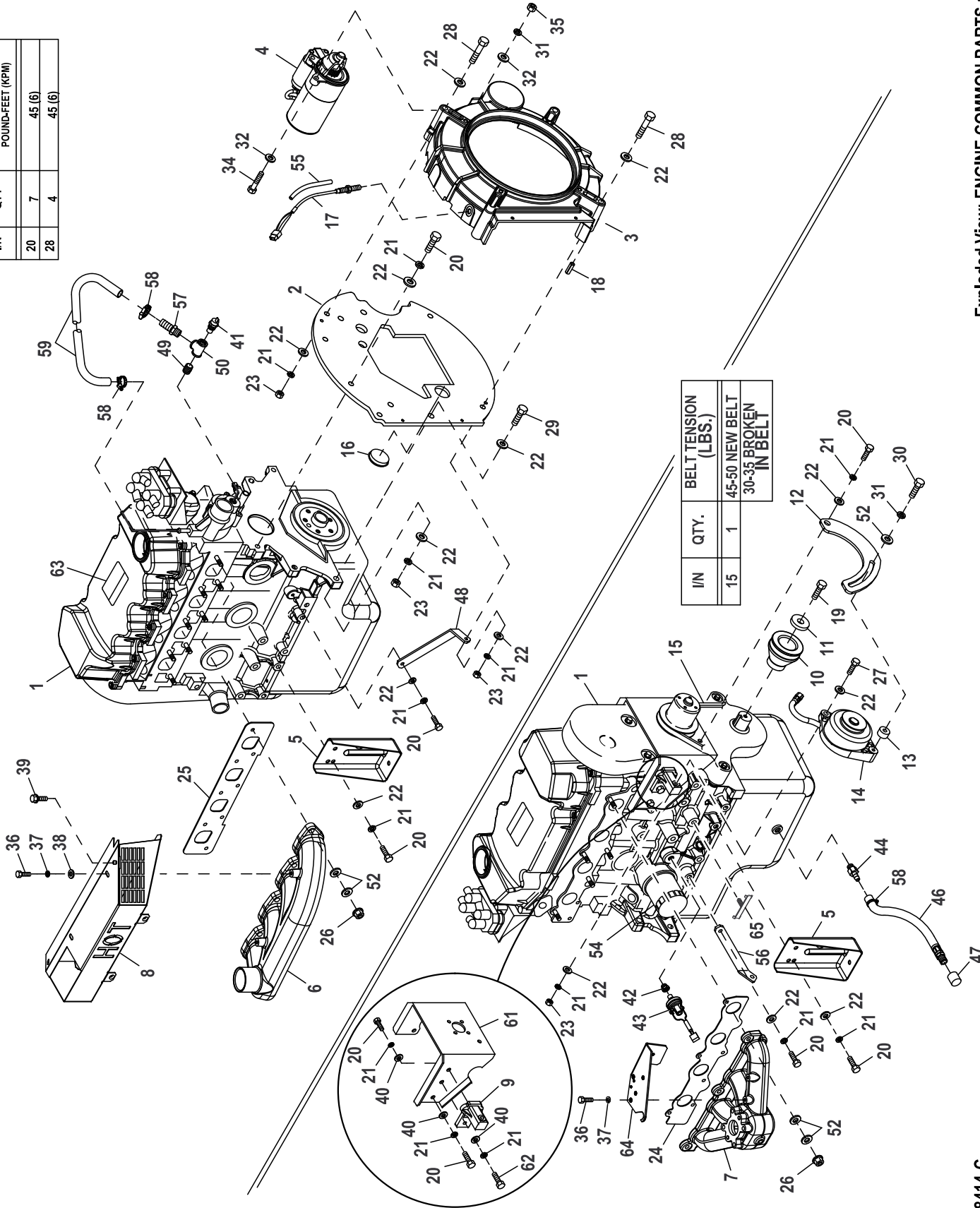

		BELT TENSION (LBS.)	
IN	QTY.		
15	1	45-50 NEW BELT	
		30-35 BROKEN	IN BELT

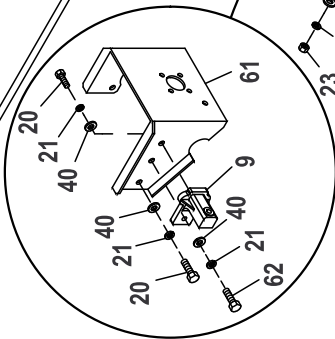

EXPLODED VIEW: ENGINE COMMON PARTS 1.6L

DRAWING #: 0H7219

GROUP D

APPLICABLE TO:

ITEM	PART#	QTY.	DESCRIPTION
1	0H1734	REF	ENGINE GENERAC 1.6L G11 CERT
2	0G0834A	1	ENGINE PLATE 1.6L 6MM (TO BE USED WITH PLATE SPACER P/N 0G2070A.)
3	0G0820A	REF	HOUSING BLOWER LG PILOT
4	0G7461	1	STARTER MOTOR 12V
5	0G0839	2	ENGINE MOUNTING FOOT STAMPING
6	0G0781	1	EXHAUST MANIFOLD 1.6L MACHINED
7	0G0722	1	INTAKE MANIFOLD MACHINED 1.6L
8	0G4059	1	SHIELD 1.6L EXHAUST HEAT
9	0G4604	1	DC ALTERNATOR ADAPTER MACHINED
10	0G3424	1	PULLEY CRANKSHAFT MACHINED
11	0G0786	1	WASHER PULLEY
12	0G4605	1	BRACKET TENSIONER DC ALT
13	0F9617A	1	SPACER ALTERNATOR
14	0A1354B	1	DC ALTERNATR HAN-KOK
15	0G0823	1	V-BELT 3/8 X 30.6
16	0G3900	1	CAP, 1.5" HOLE SHALLOW
17	0D2244M	1	ASSY MAGPICKUP (3/8-24 MALE)
18	036710	2	PIN SPRING 1/4 X 3/4
19	0C5479	1	SCREW HHC M12-1.5 X 40 G10.9
20	059980	13	SCREW HHC M10-1.5 X 25 G10.9
21	046526	22	WASHER LOCK M10
22	022131	18	WASHER FLAT 3/8-M10 ZINC
23	0G3922	9	NUT HEX M10-1.5 CLASS 10 ZINC
24	0G0464	1	GASKET INTAKE MANIFOLD 1.6L
25	0G0465	1	GASKET EXHAUST MANIFOLD 1.6L
26	052858	14	NUT TOP LOCK FL M8-1.25
27	051735	1	SCREW HHC M10-1.5 X 70 G8.8
28	0G3920	4	SCREW HHC M10-1.5 X 110 G10.9
29	0A7387	4	SCREW HHC M10-1.5 X 40 G10.9
30	039414	1	SCREW HHC M8-1.25 X 35 G8.8
31	022129	4	WASHER LOCK M8-5/16
32	022145	3	WASHER FLAT 5/16-M8 ZINC
33	029333A	1	TIE WRAP UL 7.4" X .19" BLK
34	057821	3	SCREW HHC M8-1.25 X 40 G8.8
35	045771	3	NUT HEX M8-1.25 G8 CLEAR ZINC
36	022507	4	SCREW HHC 1/4-20 X 1/2 G5
37	022097	4	WASHER LOCK M6-1/4
38	022473	5	WASHER FLAT 1/4-M6 ZINC
39	090388	3	SCREW HHTT M6-1.0 X 12 ZINC
40	0A5768	5	WASHER FLAT M10 HEAVY DUTY
41	0E0502	1	TEMPERATURE SENDER, DELPHI
42	035579	1	BSHG RDCR HEX 1/4 TO 1/8
43	0H7435	1	HARN LOW OIL PRESS SWITCH ASSY
44	0C1852	1	ADAPTER DRAIN OIL
46	069860C	1	HOSE OIL DRAIN ASSY 21"
47	069811	1	CAP HEX 1/4 NPT BRASS
48	0G38580ST03	1	STRUT LH 1.6L ENG ADAPT PLATE
49	025065	1	NIPPLE PIPE 3/8 NPT X 1-1/2
50	027738A	1	PIPE TEE 3/8 NPT
51	0E3257	3	SCREW HWHTF M6-1.0 X 16
52	0A8830	29	WASHER FLAT .34 ID X .75 OD
53	0H6690	1	HARN ENG G1.6L G11 NEXUS (NOT SHOWN)
54	0G02070100	1	OIL FILTER 1.6L
55	077043H	1	CONDUIT FLEX .25"ID (6" LG)
56	0G38620ST03	1	STRUT RH 1.6L ENG ADAPT PLATE
57	055596	1	BARBED STR 3/8 NPT X 3/8
58	0C7649	3	CLAMP HOSE .38- .87
59	0H2250	1	HOSE COOLANT 3/8 ID 20R3 (11" LG)
61	0G3433	REF	BRACKET FAN ALT ADAPTER 1.6L
62	049541	1	SCREW HHC M10-1.5 X 35 G8.8
63	0G7311	REF	DECAL EMISSION CTRL INFO 1.6L
64	0G4451	1	BRACKET STEPPER MOTOR COOLANT
65	0F4001E	1	ANCHOR HARNESS

GROUP E

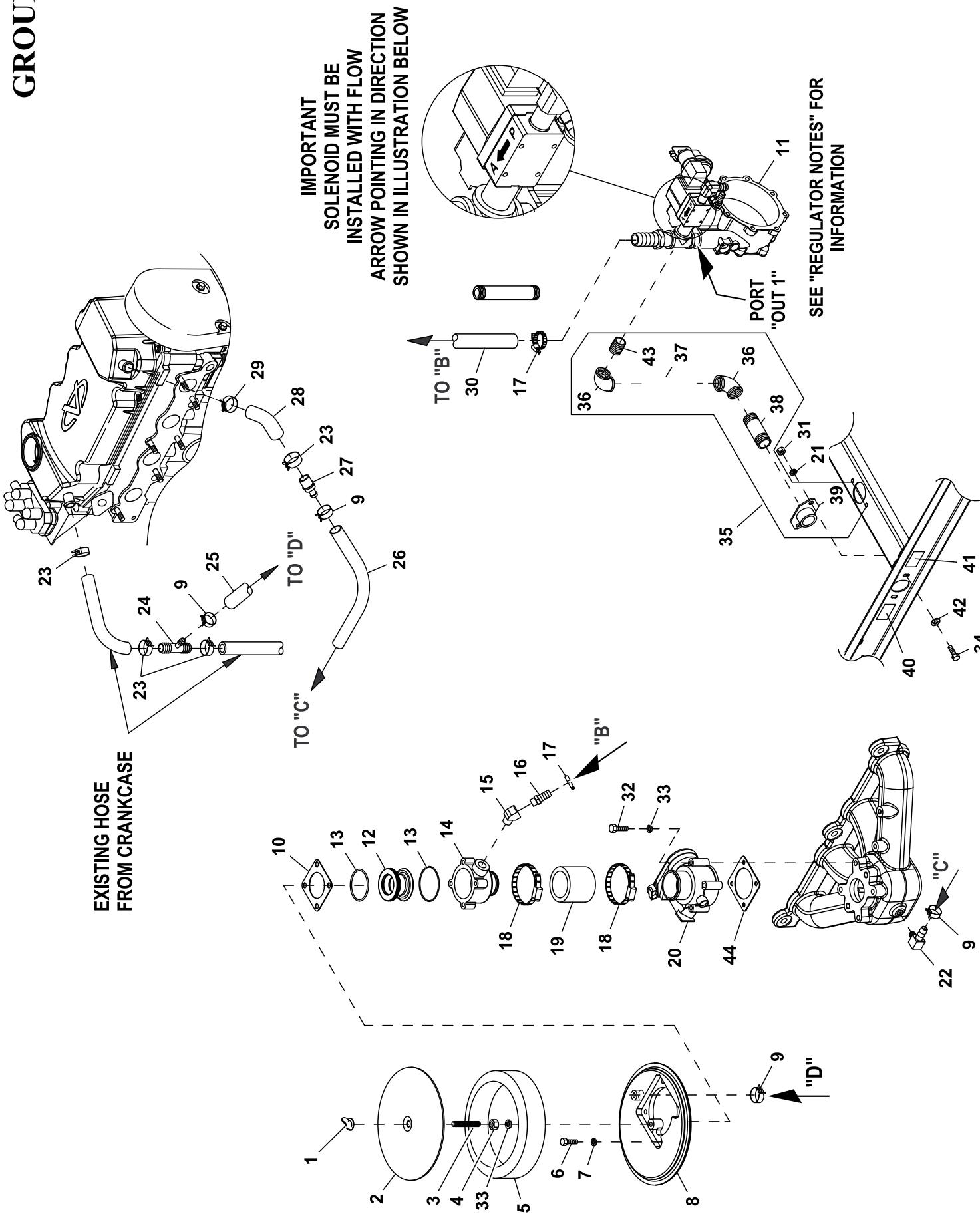

EXISTING HOSE FROM CRANKCASE

IMPORTANT
SOLENOID MUST BE
INSTALLED WITH FLOW
ARROW POINTING IN DIRECTION
SHOWN IN ILLUSTRATION BELOW

SEE "REGULATOR NOTES" FOR
INFORMATION

EXPLODED VIEW: FUELSYS NG/LPV 1.6L CPL**DRAWING #: 0H6671****GROUP E****APPLICABLE TO:**

ITEM	PART#	QTY.	DESCRIPTION
1	037561	1	NUT WING 1/4-20 NYLK
2	0A5547	1	COVER AIR CLEANER
3	062522	1	STUD TH 1/4-20 X 3 G2 ZNC FULL
4	022127	1	NUT HEX 1/4-20 STEEL
5	059402	1	FILTER ELEMENT
6	091526	4	SCREW PPHM M5-0.8 X 12 ZNC
7	049226	4	WASHER LOCK M5
8	0E0519A	1	ADAPTER, CARBURETOR W/PVC CONN
9	048031J	4	CLAMP HOSE BAND .63
10	0E6586	1	GASKET BOSCH 32 & 40
11	0G1397E	1	FUEL REG. REWORK 1.6L
12	0F7790	1	VENTURI THROTTLE 21MM
13	0E7121	2	O-RING 47.625 ID X 2.38 WIDTH
14	0G4573C	1	MIXER ACTUATOR 32MM MACHINED
15	0E8286	1	STREET EL 45D 1/2 NPT BRASS
16	047527	1	BARBED STR 1/2 NPT X 3/4
17	057823	2	CLAMP HOSE #10 .56-1.06
18	035685	2	CLAMP HOSE #28 1.32-2.25
19	057753B	1	HOSE 1.5 ID X 2 LG 20R4
20	0E4395	1	ACTUATOR BOSCH 32 GOVERNOR
21	022129	2	WASHER LOCK M8-5/16
22	0A6344	1	BARBED EL 90 1/8 NPT X 3/8
23	048031L	4	CLAMP HOSE BAND 1.0"
24	0G1985	1	HOSE BARB REDUCR TEE 3/4"-3/8"
25	047290	1	HOSE 3/8 ID SINGLE BRAID (11.5" LG)
26	047290	1	HOSE 3/8 ID SINGLE BRAID (12" LG)
27	0F3994	1	PCV VALVE 2.5L FORD
28	0G3178	1	HOSE BREATHER 1.6L
29	048031P	1	CLAMP HOSE BAND .88"
30	059057	1	HOSE 3/4 ID SAE-30R2 (16"LG)
31	045771	2	NUT HEX M8-1.25 G8 YEL CHR
32	051767	4	SCREW HHC M6-1.0 X 45 C8.8 FTH
33	022097	5	WASHER LOCK M6-1/4
34	039253	2	SCREW HHC M8-1.25 X 20 G8.8
35	0G9348	1	ASSY REG INLET NPT FITTINGS
(1)36	026812	2	ELBOW 90D 3/4 NPT
(1)37	076691	1	NIPPLE PIPE 3/4NPTX4.5 BLK IRN
(1)38	026490	1	NIPPLE PIPE 3/4NPT X 2
(1)39	075580	1	FLANGE FUEL INLET
40	0D1509	1	DECAL INLET PRESSURE
41	075436	1	DECAL FUEL INLET
42	022145	2	WASHER FLAT 5/16 ZINC
(1)43	026915	1	NIPPLE CLOSE 3/4 X 1.375
44	0E6586A	1	GASKET BOSCH 32

(1) INCLUDED IN ITEM 35 (ASSY REG INLET NPT FITTINGS)

REGULATOR NOTES:

REGULATOR (I/N 11) AS SHOWN IN ILLUSTRATION IS SET UP FOR NATURAL GAS APPLICATION. TO CONFIGURE REGULATOR FOR LP VAPOR, REFER TO THE "RECONFIGURING THE FUEL SYSTEM" SECTION OF THIS MANUAL.

GROUP F

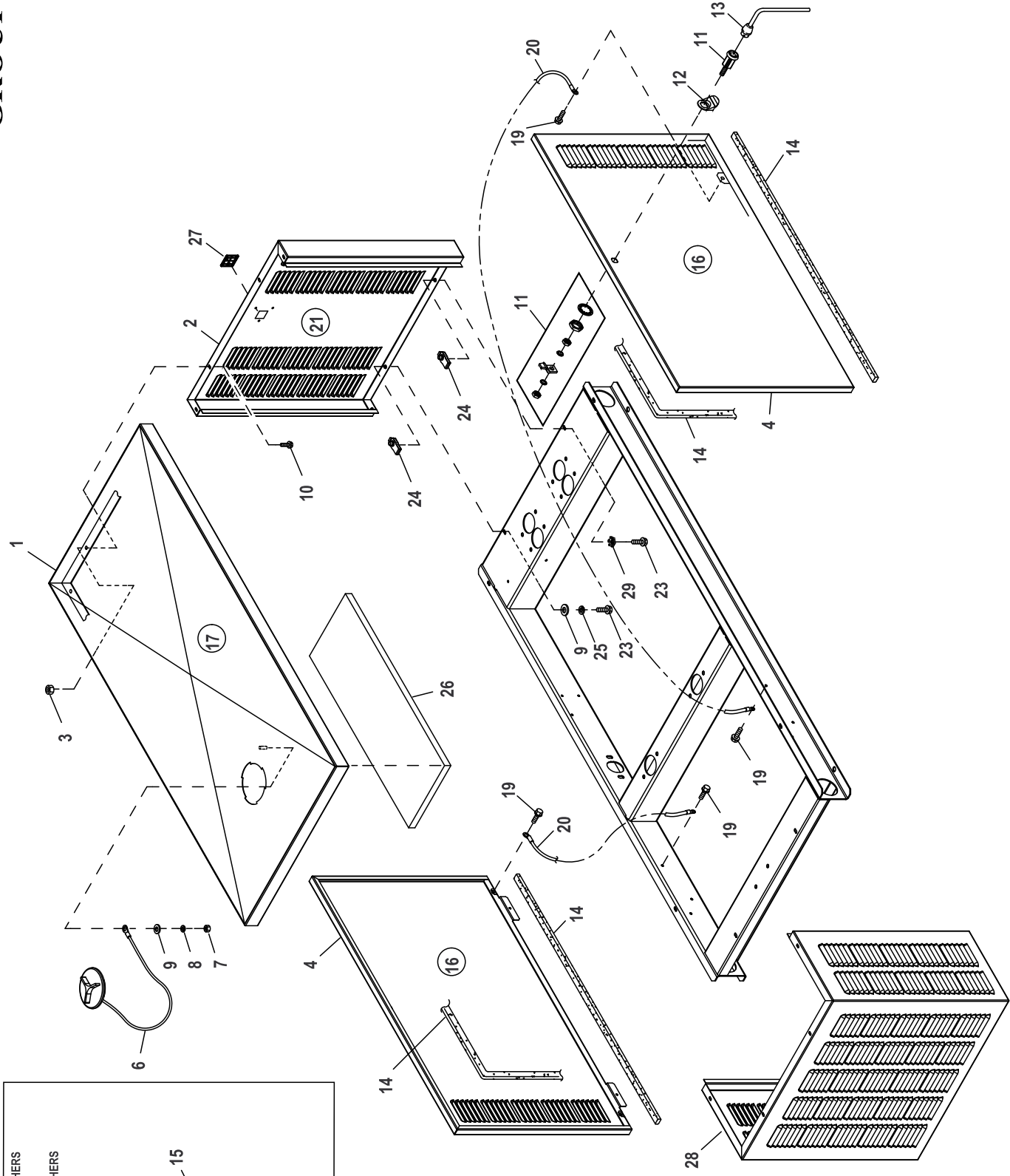

INSULATION AND DOME WASHERS LOCATED ON THE NEAR SIDE.
 INSULATION AND DOME WASHERS LOCATED ON THE FAR SIDE.

TYPICAL MOUNTING OF ROOF ACOUSTIC INSULATION.

EXPLODED VIEW: EV ENCLOSURE C1 CPL

DRAWING #: 0G3534

GROUP F

ITEM	PART#	QTY.	DESCRIPTION
(2) 1	0G33370AL0R	1	ROOF 1.6L C1
(2) 2	0J14640AL0R	1	REAR INTAKE WRAP C1
(1) 3	077992	10	NUT HEX LOCK M6-1.0 SS NY INS
(2) 4	0J14630AL0R	2	DOOR LEFT/RIGHT SIDE C1
6	0F4487A	1	ASSY ACCESS COVER
7	022127	1	NUT HEX 1/4-20 STEEL
8	022097	1	WASHER LOCK M6-1/4
9	022473	10	WASHER FLAT 1/4-M6 ZINC
(1)10	0C2454	8	SCREW THF M6-1 X 16 N WA Z/JS
11	0F5048D	2	WISE-ACTION LATCH, SLOTTED CIR
12	0F5049B	2	PULL TAB DOOR LOCK SS
13	0F8869D	1	KEY VISE-ACTION LATCH,SLOT CIR
14	089961	1	FOAM STRIP 3/4"WIDE X 3/16"THK (294"LG)
15	078115	8	WASHER SELF LOCKING DOME
16	0H7518	2	INSULATION SIDE DOOR C1
17	0H7518A	1	INSULATION ROOF C1
(1)19	0E3257	6	SCREW HWHTF M6-1.0 X 16
20	0912970090	2	ASSY WIRE 14AWG GRN/YEL (32.25"LG)
21	0H7518B	1	INSULATION REAR C1
23	0C8566	10	SCREW HHFC M6-1.0 X 20 G8.8
24	0H0412	10	NUT SPRINGCLIP M6-1.0
25	022097	8	WASHER LOCK M6-1/4
(3) 26	0H7529	1	FOIL ALUMINUM WITH ADHESIVE
27	0H1208A	1	RF COVER PLATE-PLASTIC-BISQUE
	0H1208B	1	RF COVER PLATE-PLASTIC-GREY
(2) 28	0G33350AL0R	1	FRONT DISCHARGE WRAP 1.6L C1
(1)29	0A1658	2	WASHER LOCK SPECIAL 1/4"

(1)ENCLOSURE NOTE: ALL PANELS THAT FASTEN TO THE ROOF MUST BE SECURED USING I/N 10 (THREAD FORMING FASTENER) AND I/N 3 (LOCK NUT) AND TO INCLUDE AT LEAST ONE CONNECTION POINT USING I/N 19 (THREAD FORMING FASTENER) WITH I/N 3 (LOCK NUT) TO EACH PANEL. LOCK NUT IS TO BE INSTALLED AFTER THREAD FORMING FASTENER HAS PENETRATED THROUGH EXTRUSION IN ENCLOSURE PANELS. ALL PANEL TO BASEFRAME CONNECTIONS TO INCLUDE AT LEAST ONE CONNECTION POINT USING I/N 29 (WASHER SPECIAL).

(2) SHEET METAL PARTS LISTED IN THE BOM TABLE ARE REPRESENTING GENERIC PARTS (NO COLOR)

- MANUFACTURING: FOR CORRECT MATERIAL AND COLOR REFER TO AS400 BOM.
- CUSTOMER: WHEN ORDERING REPLACEMENT PARTS ENTER BASE NUMBER (FIRST 6 DIGITS ONLY) IN THE SYSTEM FOR CORRECT MATERIAL AND COLOR (FOR REFERENCE SEE GUIDELINE 0H7169).

(3) USED ON 1.5L / 1.6L UNITS ONLY.1

GROUP F

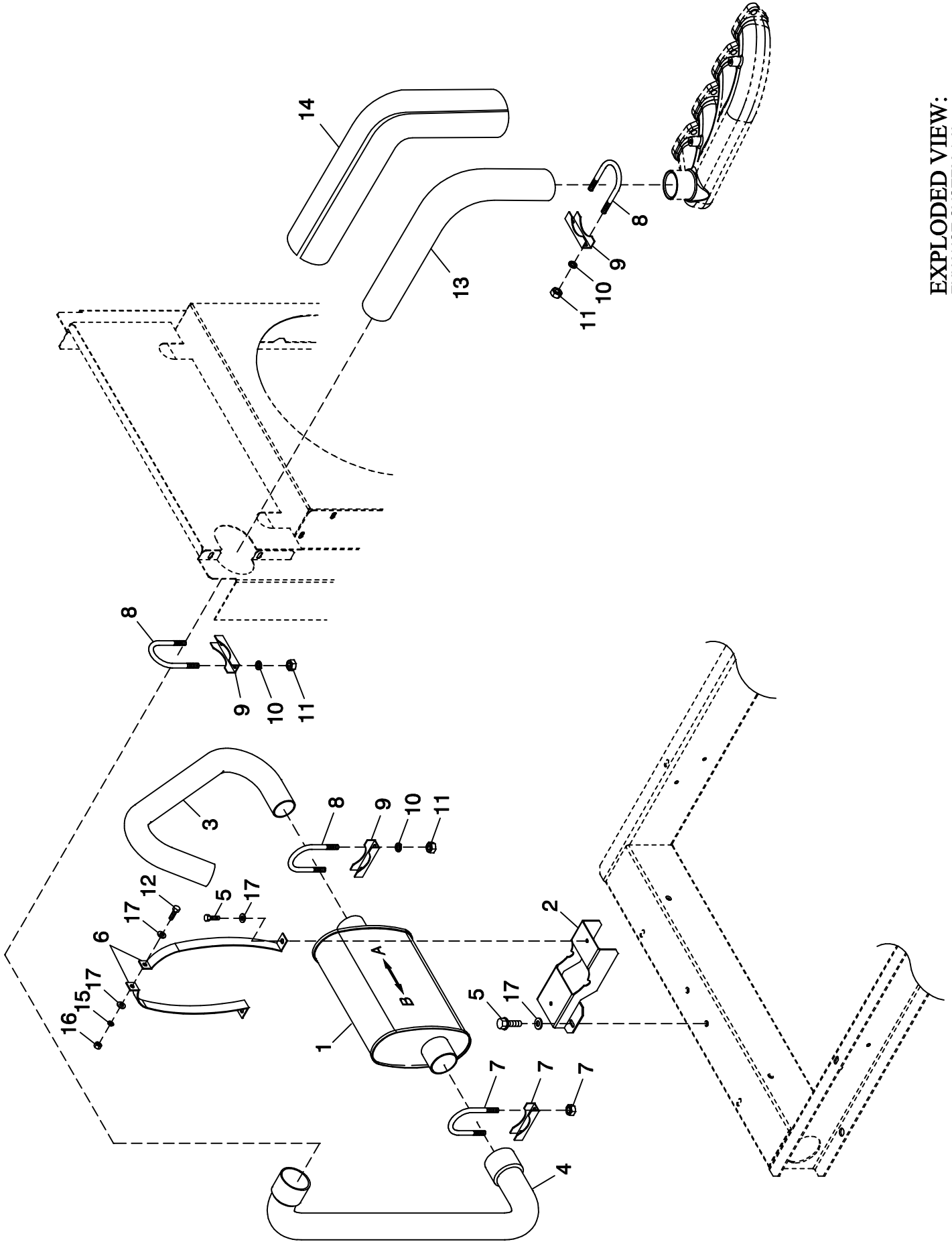

EXPLODED VIEW:
EXHAUST SYSTEM 1.6L
DRAWING #: 0G3535

EXPLODED VIEW: EXHAUST SYSTEM 1.6L

DRAWING #: 0G3535

GROUP F

APPLICABLE TO:

ITEM	PART #	QTY.	DESCRIPTION
1	0F7366	1	MUFFLER C1
2	0F7647	1	MUFFLER SADDLE
3	0F8095	1	PIPE EXHAUST OUTLET
4	0G3576	1	EXHAUST PIPE LOWER 1.6L
5	0E3257	4	SCREW HWHTF M6-1.0 X 16
6	0F7644	2	MUFFLER STRAP
7	0C6119	1	BOLT U 5/16-18 X 2-1/4
8	036434	3	BOLT U 5/16-18 X 2.09
9	036449	3	SADDLE 2 INCH
10	022129	6	WASHER LOCK M8-5/16
11	022259	6	NUT HEX 5/16-18 STEEL
12	038750	1	SCREW HHC M6-1.0 X 30 G8.8
13	0G3575	1	EXHAUST PIPE UPPER 1.6L SS
14	0F3794A	1	EXHAUST BLANKET 500MM LONG
15	022097	1	WASHER LOCK M6-1/4
16	049813	1	NUT HEX M6 X 1.0 G8 YEL CHR
17	022473	6	WASHER FLAT 1/4-M6 ZINC

GROUP G

NOTES:

- 1) MINIMUM RECOMMENDED CONCRETE PAD SIZE: 1041 (41.0") WIDE X 1892 (74.5") LONG. REFERENCE INSTALLATION GUIDE SUPPLIED WITH UNIT FOR CONCRETE PAD GUIDELINES.
- 2) ALLOW SUFFICIENT ROOM ON ALL SIDES OF THE GENERATOR FOR MAINTENANCE AND SERVICING. THIS UNIT MUST BE INSTALLED IN ACCORDANCE WITH CURRENT APPLICABLE NFPA 37 AND NFPA 70 STANDARDS AS WELL AS ANY OTHER FEDERAL, STATE AND LOCAL CODES FOR MINIMUM DISTANCES FROM OTHER STRUCTURES.
- 3) CIRCUIT BREAKER INFORMATION:
SEE SPECIFICATION SHEET WITHIN OWNERS MANUAL
- 4) INSIDE STUB-UP AREA FOR AC LOAD LEAD CONDUIT CONNECTION, NEUTRAL CONNECTION, BATTERY CHARGER 120 VOLT AC (.5 AMP MAX.) CONNECTION, ACCESS TO TRANSFER SWITCH CONTROL WIRES, AND TRANSFER SWITCH CONNECTION (IF SO EQUIPPED). REMOVE FRONT COVER FOR ACCESS.
- 4A) FIELD CUT HOLE IS ONLY REQUIRED FOR MOUNTING OF GENERATOR ON AN EXISTING PAD.
- 5) REFERENCE OWNERS MANUAL FOR LIFTING WARNINGS.
- 6) REMOVE LIFT-OFF ENCLOSURE TO ACCESS EXHAUST MUFFLER.

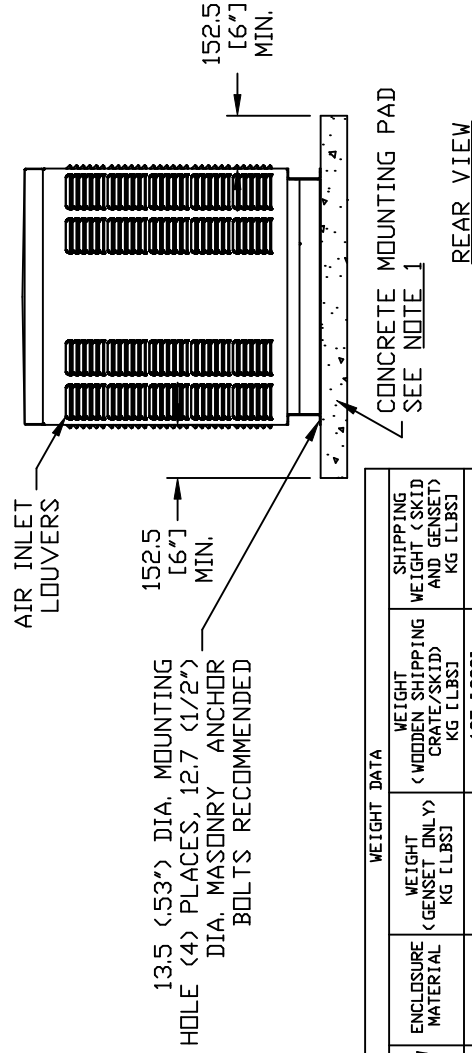

ENGINE/KW	WEIGHT DATA				
	ENCLOSURE MATERIAL	WEIGHT (GENSET ONLY) KG [LBS]	WEIGHT (WOODEN SHIPPING CRATE/SKID) KG [LBS]	SHIPPING WEIGHT (SKID AND GENSET) KG [LBS]	
1. 6L/18KW	STEEL	424 [935]	127 [280]	551 [1215]	
	ALUMINUM	383 [845]	127 [280]	510 [1125]	
1. 6L/20KW	STEEL	397 [875]	127 [280]	524 [1155]	
	ALUMINUM	356 [785]	127 [280]	483 [1065]	
1. 6L/25KW	STEEL	397 [875]	127 [280]	524 [1155]	
	ALUMINUM	356 [785]	127 [280]	483 [1065]	
1. 6L/30KW	STEEL	424 [935]	127 [280]	551 [1215]	
	ALUMINUM	383 [845]	127 [280]	510 [1125]	

EXPLODED VIEW:
INSTALLATION DRAWING C1 CPL
DRAWING #: 0G5116

GROUP G

SERVICE ITEM ACCESSIBILITY CHART

SERVICE ITEM	ACCESS
OIL FILL CAP	EITHER DOOR
OIL DIP STICK	THRU RIGHT DOOR
OIL FILTER	THRU RIGHT DOOR
OIL DRAIN HOSE	THRU RIGHT DOOR
RADIATOR DRAIN HOSE	THRU RIGHT DOOR
AIR CLEANER ELEMENT	THRU RIGHT DOOR
SPARK PLUGS	THRU RIGHT DOOR
MUFFLERS	SEE NOTE 6
FAN BELT	THRU RIGHT DOOR
BATTERY	THRU RIGHT DOOR

REFERENCE OWNERS MANUAL FOR PERIODIC REPLACEMENT PART LISTINGS

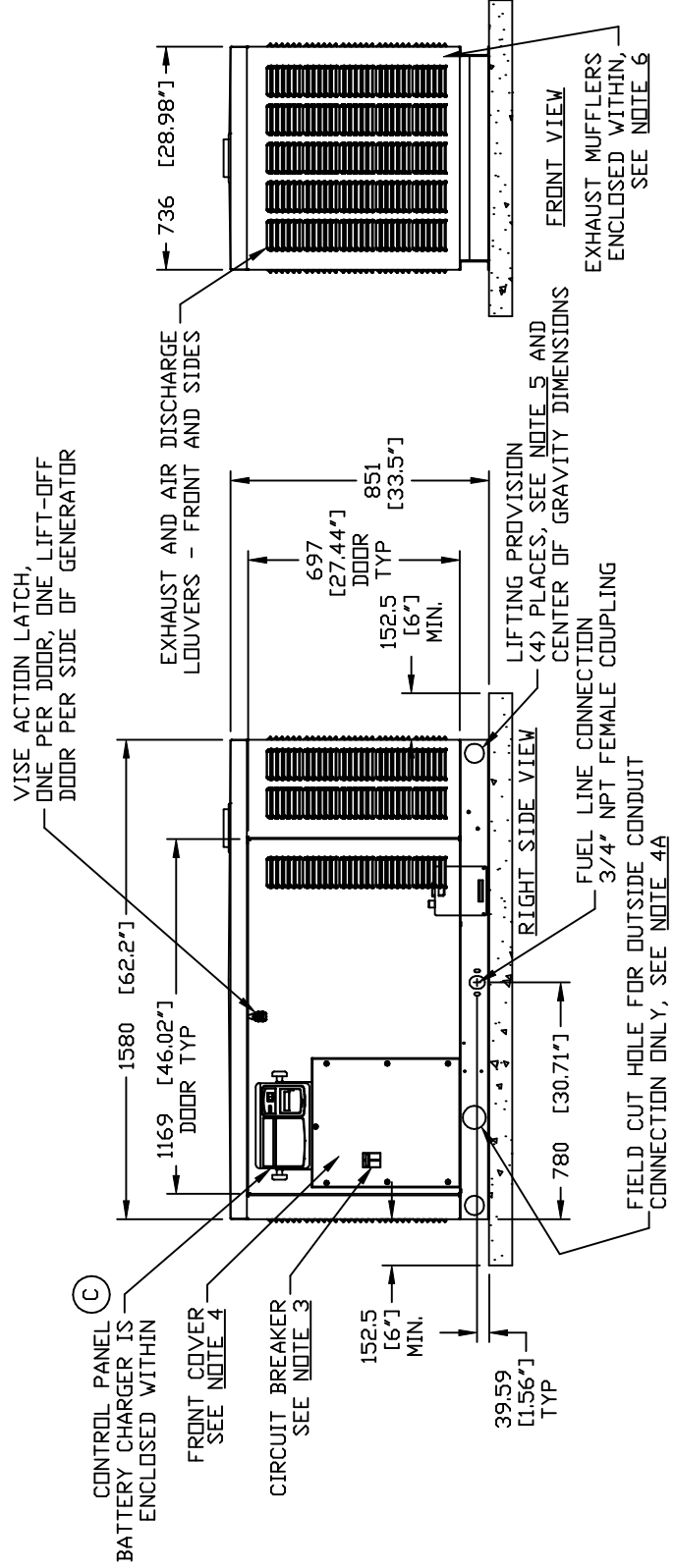
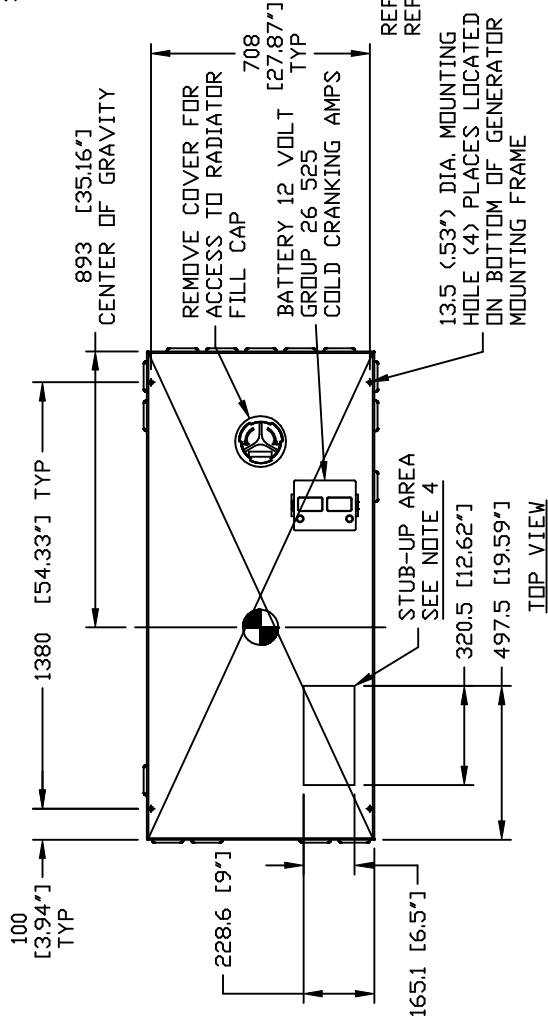

EXPLODED VIEW:
INSTALLATION DRAWING C1 CPL
DRAWING #: 0G5116

OPTION 1 - SINGLE PHASE, CPL CONTROL PANEL

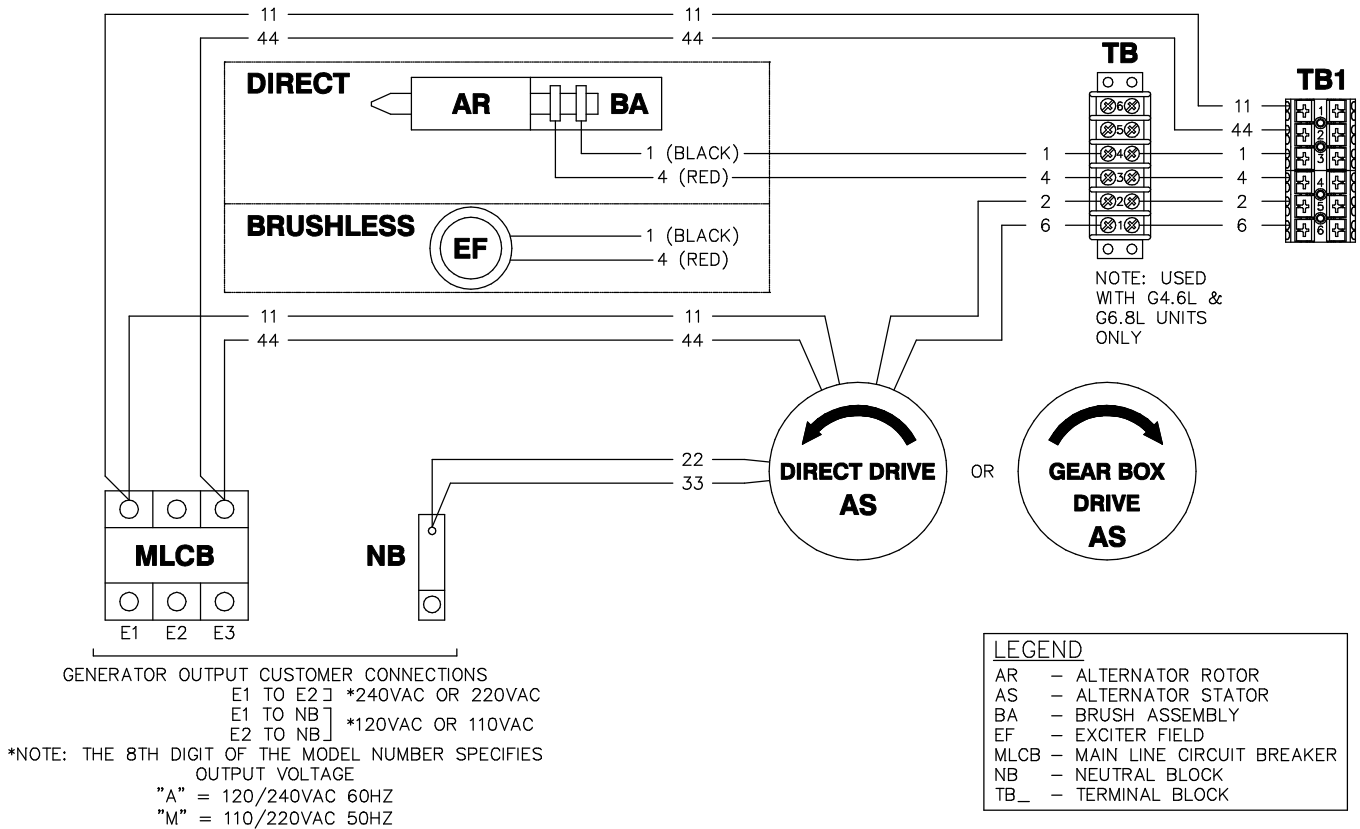

OPTION 2 - THREE PHASE, CPL CONTROL PANEL, 120/208V

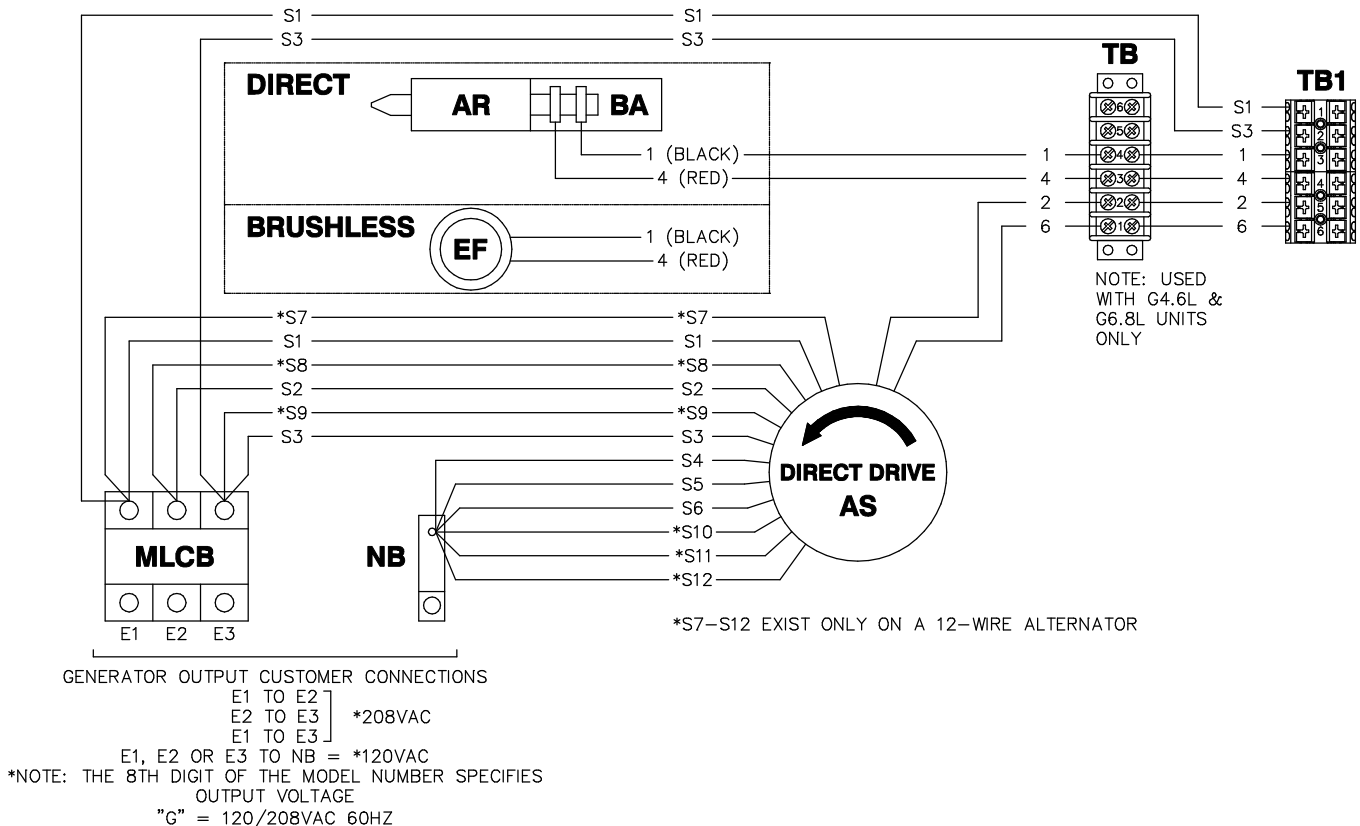

OPTION 3 - THREE PHASE, CPL CONTROL PANEL, 6-WIRE 277/480V

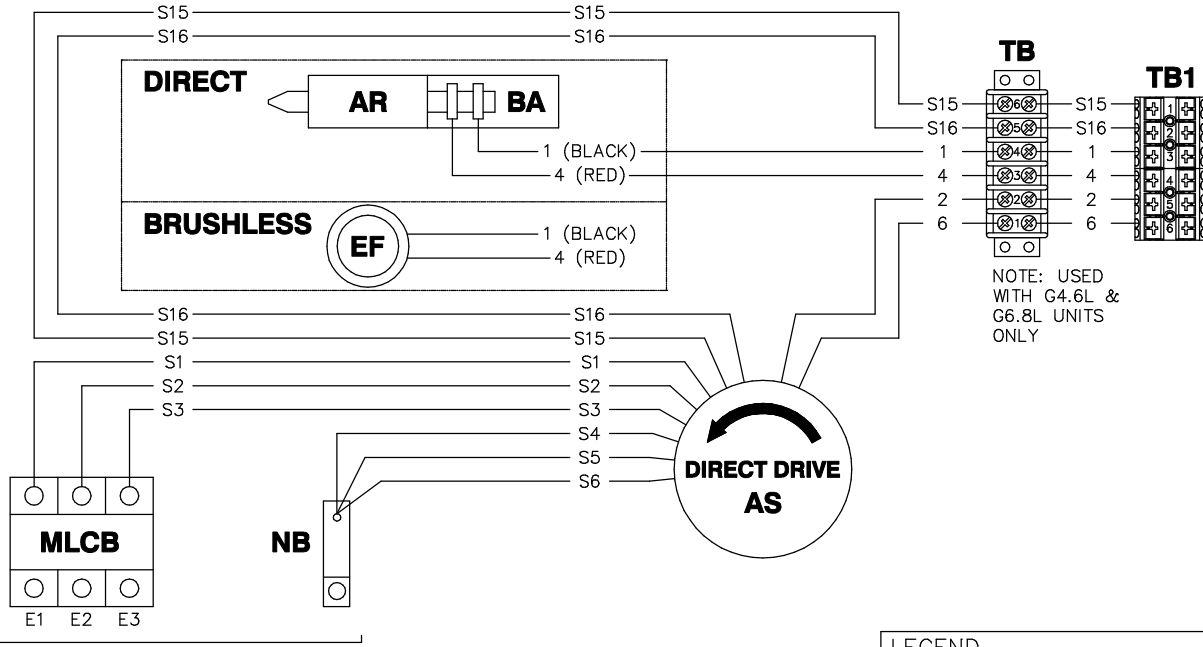

NOTE: USED WITH G4.6L & G6.8L UNITS ONLY

LEGEND	
AR	- ALTERNATOR ROTOR
AS	- ALTERNATOR STATOR
BA	- BRUSH ASSEMBLY
EF	- EXCITER FIELD
MLCB	- MAIN LINE CIRCUIT BREAKER
NB	- NEUTRAL BLOCK
TB_	- TERMINAL BLOCK

GENERATOR OUTPUT CUSTOMER CONNECTIONS

E1 TO E2
E2 TO E3] *480VAC OR *400VAC
E1 TO E3]

E1, E2 OR E3 TO NB = *277VAC OR *231VAC

*NOTE: THE 8TH DIGIT OF THE MODEL NUMBER SPECIFIES OUTPUT VOLTAGE

"K" = 277/480VAC 60HZ

"R" = 231/400VAC 50HZ

OPTION 4 - THREE PHASE DELTA, CPL CONTROL PANEL, 7-WIRE 120/240V

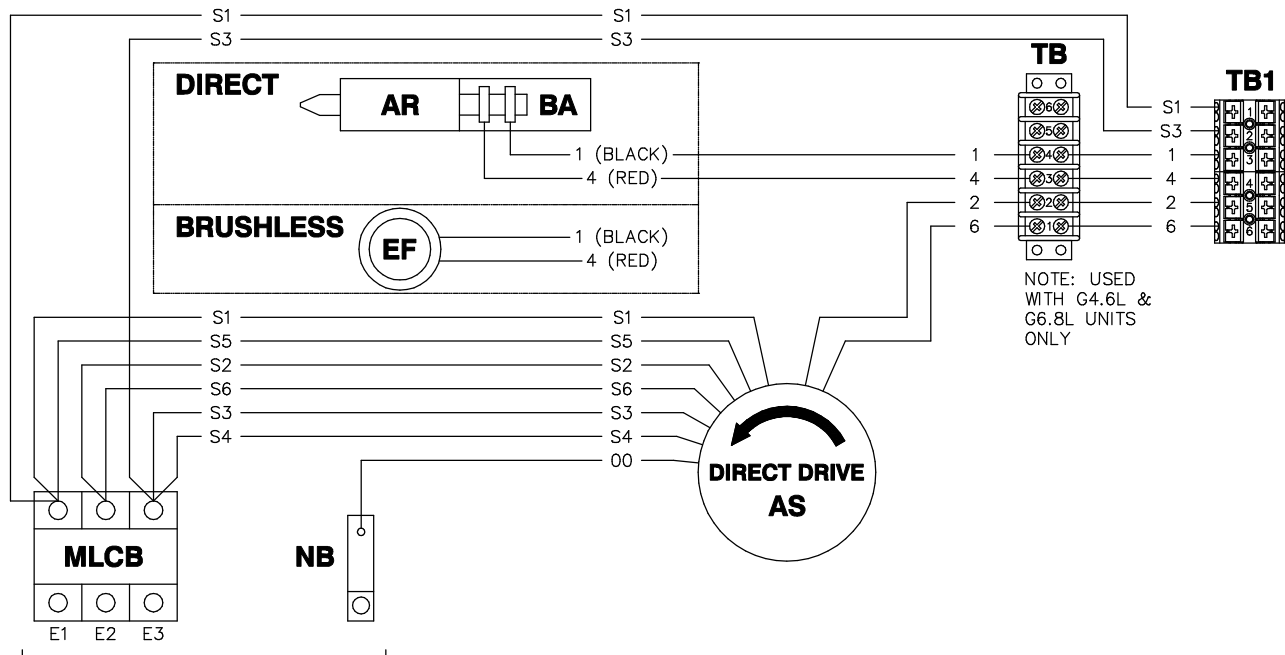

NOTE: USED WITH G4.6L & G6.8L UNITS ONLY

GENERATOR OUTPUT CUSTOMER CONNECTIONS

E1 TO E2
E2 TO E3] *240VAC
E1 TO E3]

E1 OR E3 TO NB = *120VAC

*NOTE: THE 8TH DIGIT OF THE MODEL NUMBER SPECIFIES OUTPUT VOLTAGE

"J" = 120/240VAC 60HZ

OPTION 5 - THREE PHASE, CPL CONTROL PANEL, GEARBOX (REVERSE ROTATION)

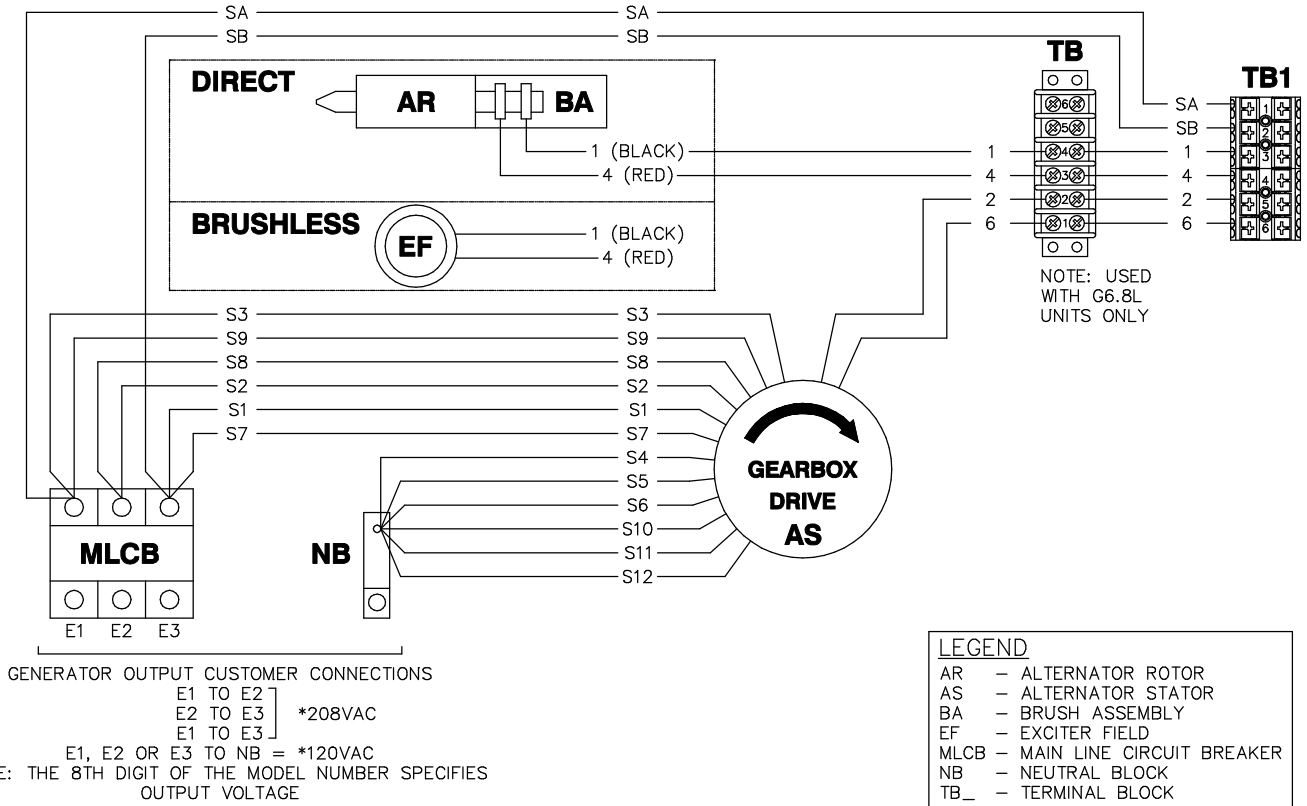

OPTION 6 - THREE PHASE, CPL CONTROL PANEL, GEARBOX (REVERSE ROTATION)

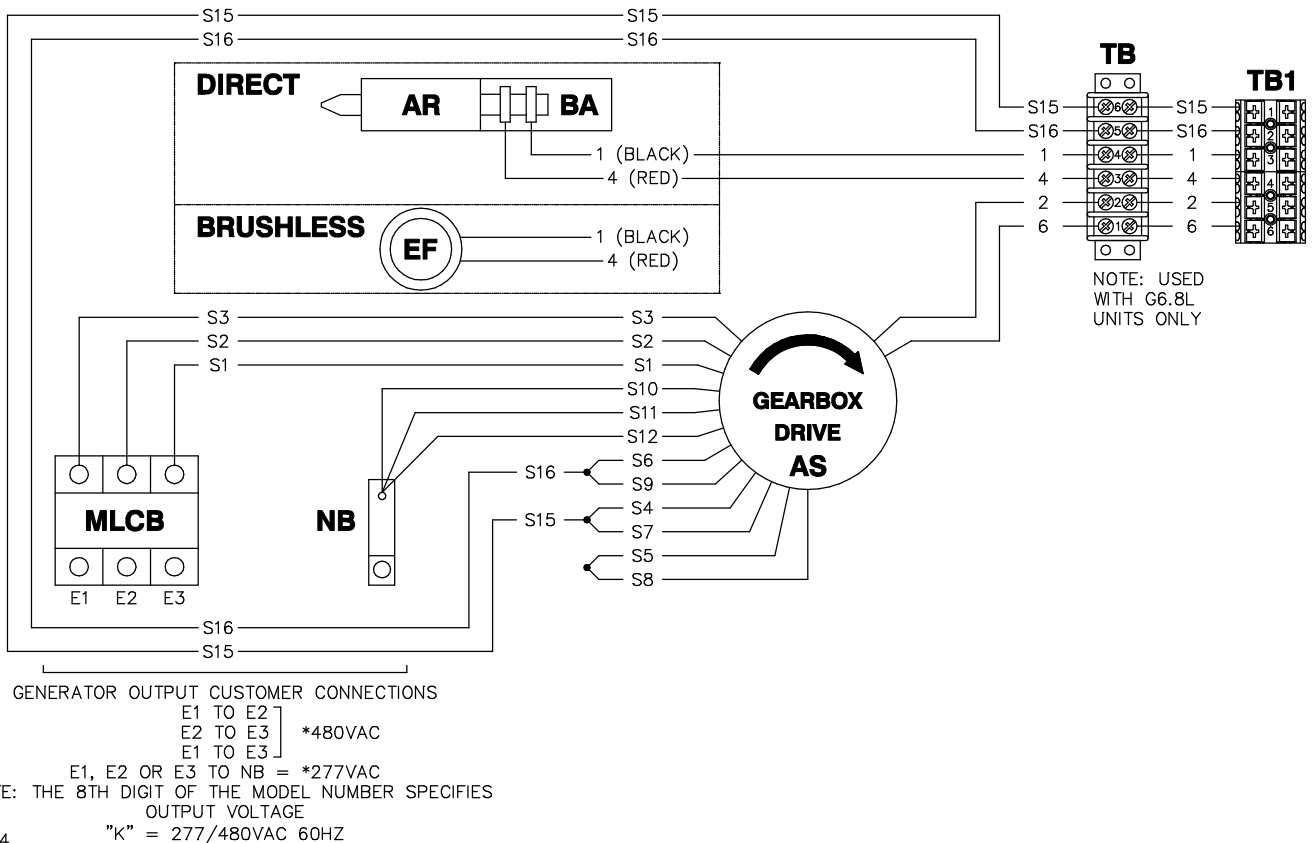

OPTION 7 - THREE PHASE SERIES DELTA, CPL CONTROL PANEL, GEARBOX (REVERSE ROTATION)

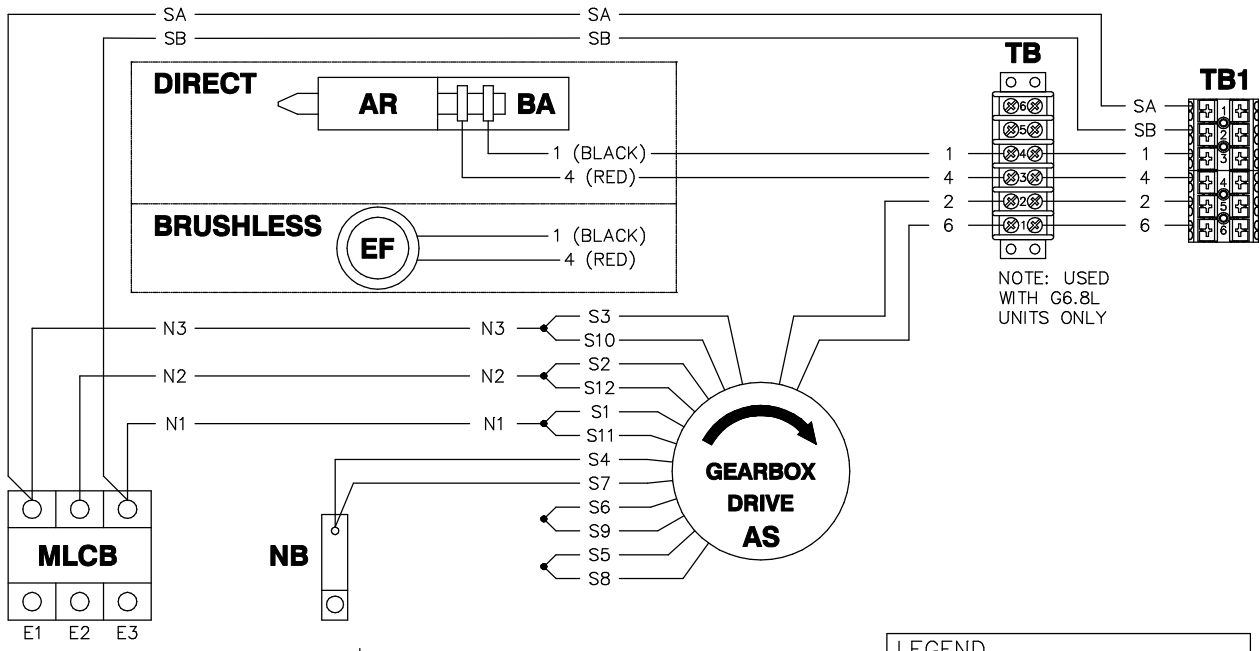

NOTE: USED WITH G6.8L UNITS ONLY

GENERATOR OUTPUT CUSTOMER CONNECTIONS
 E1 TO E2] *240VAC
 E2 TO E3]
 E1 TO E3]
 E1-N OR E2-N OR E3-N = *120VAC
 *NOTE: THE 8TH DIGIT OF THE MODEL NUMBER SPECIFIES OUTPUT VOLTAGE
 "J" = 120/240VAC 60HZ

LEGEND	
AR	- ALTERNATOR ROTOR
AS	- ALTERNATOR STATOR
BA	- BRUSH ASSEMBLY
EF	- EXCITER FIELD
MLCB	- MAIN LINE CIRCUIT BREAKER
NB	- NEUTRAL BLOCK
TB_	- TERMINAL BLOCK

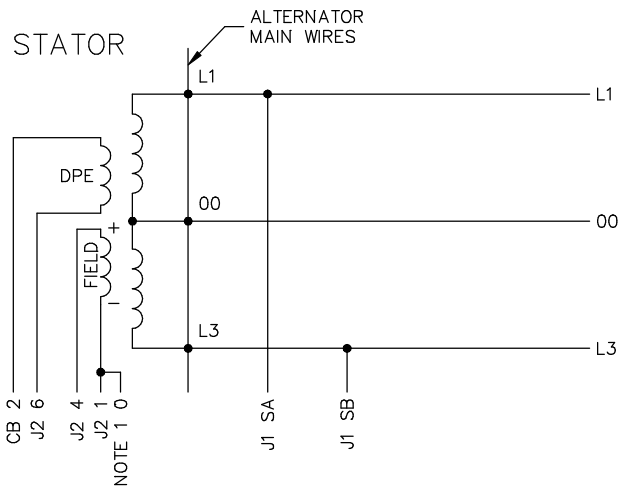

ALTERNATOR CONNECTIONS FOR 1Ø UNITS

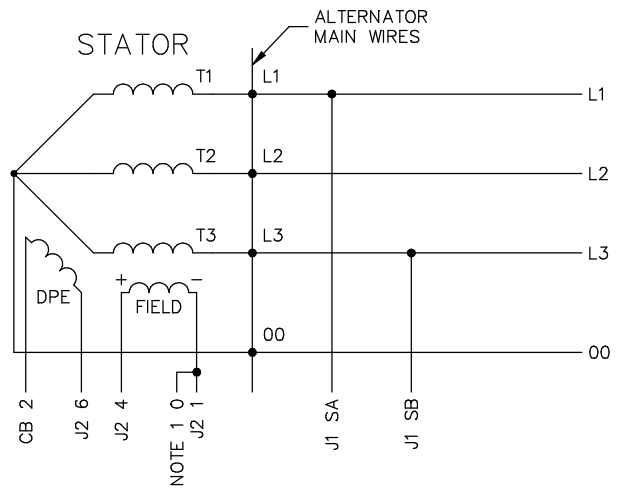

ALTERNATOR CONNECTIONS FOR 3Ø UNITS

ALTERNATOR CONNECTION BOX

GENERATOR SET

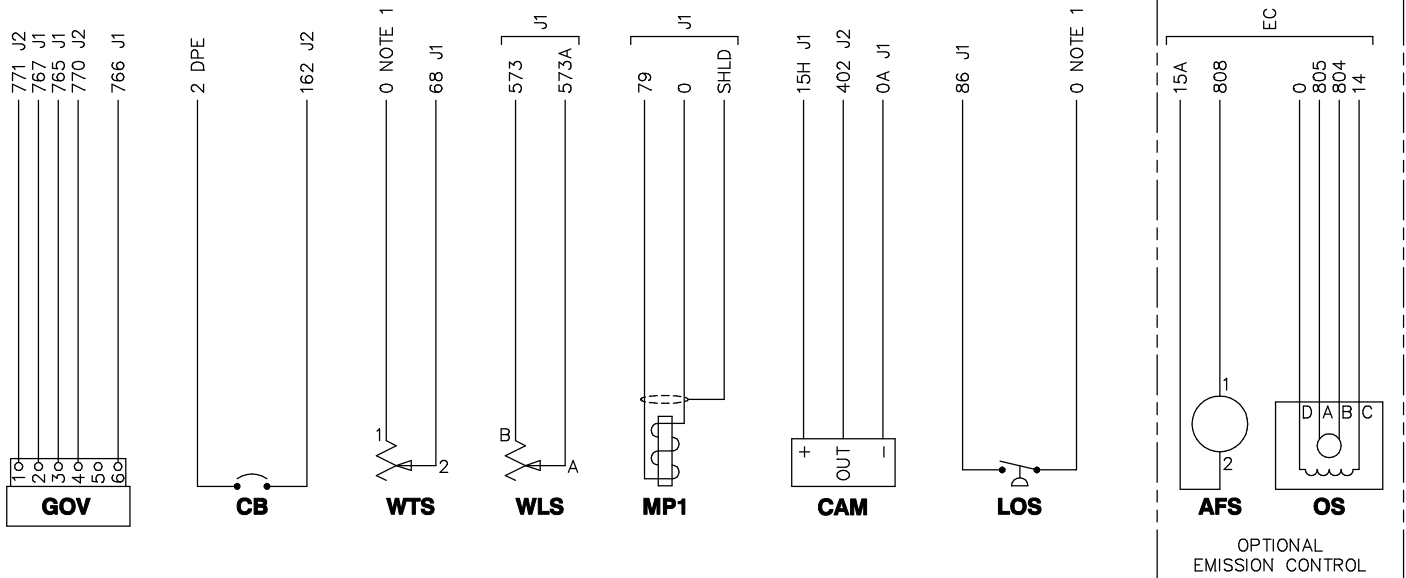

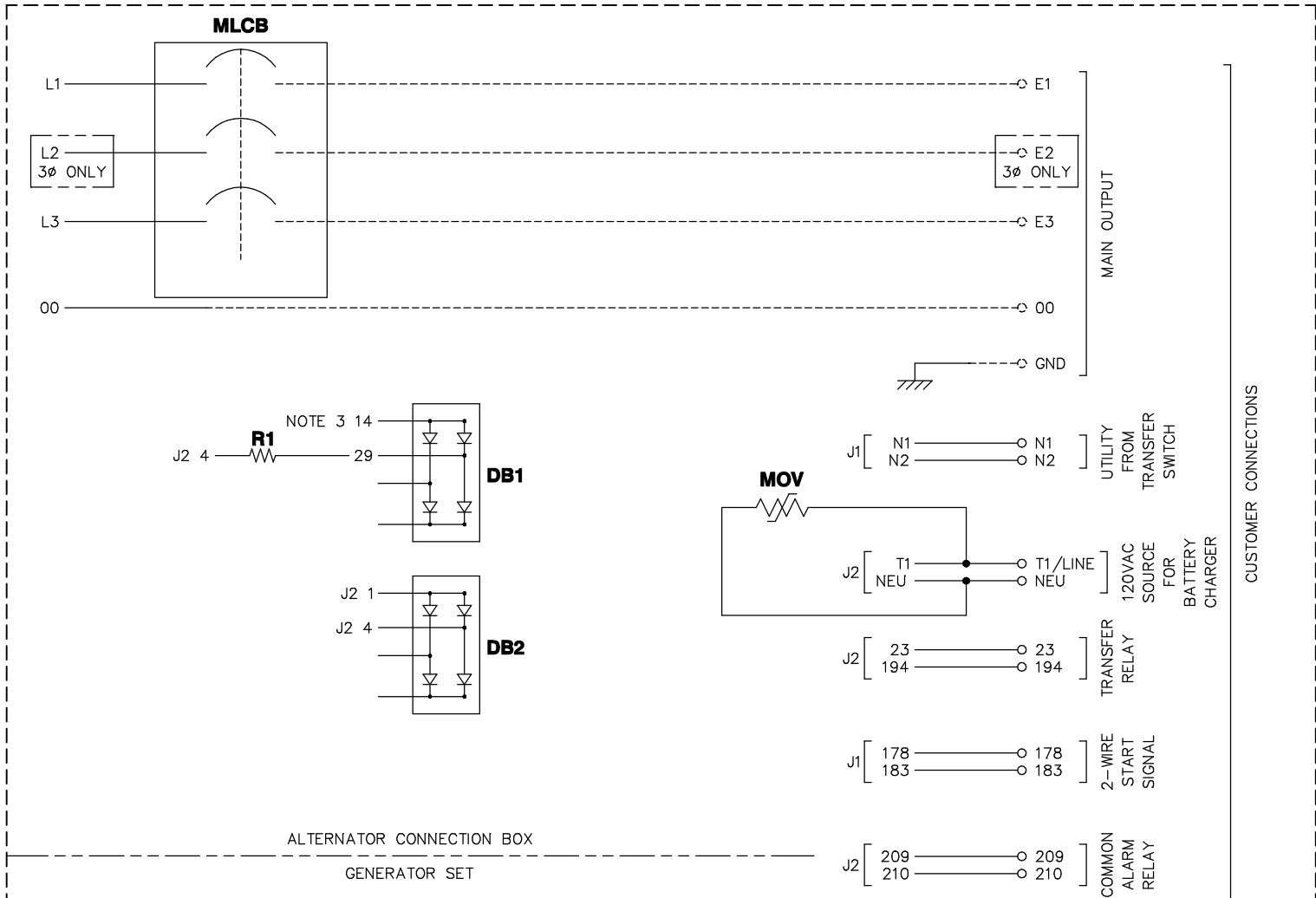

NOTE:
FOR FIELD WIRING TO CUSTOMER CONNECTIONS
(TERMINAL BLOCKS)
MAXIMUM WIRE SIZE: #12 AWG

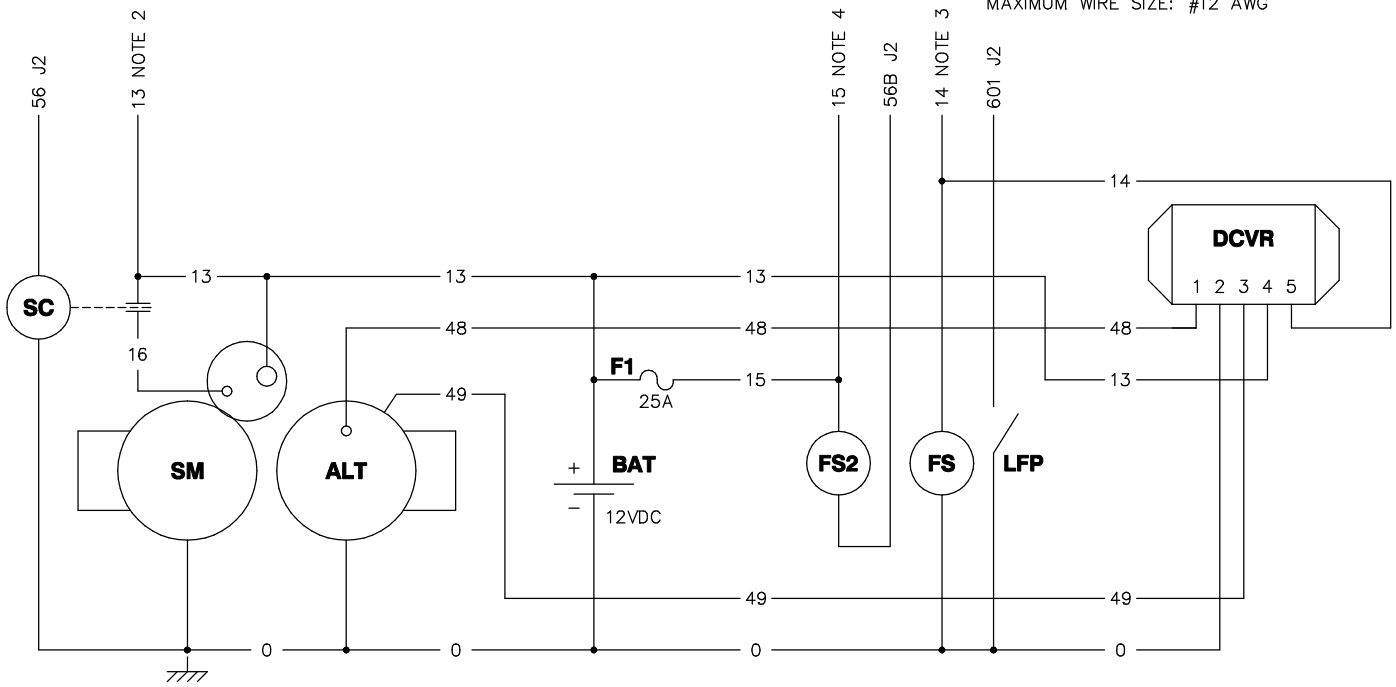

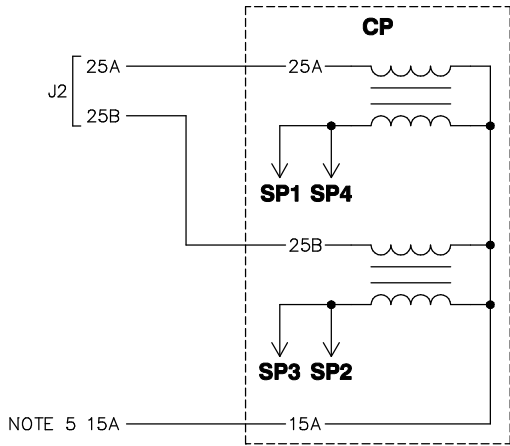

NOTES:

- 1) WIRE #0 IS CHASSIS GROUND (BATTERY-) UNLESS NOTED OTHERWISE.
- 2) WIRE #13 IS UNFUSED +12VDC (BATTERY+).
- 3) WIRE #14 IS FUSED +12VDC WHEN GENERATOR IS CRANKING OR RUNNING.
- 4) WIRE #15 IS FUSED +12VDC FOR GENERAL USE.
- 5) WIRE #15A IS FUSED +12VDC FOR THE AIR/FUEL SOLENOID OPTION AND FOR THE IGNITION COILS.

BWR CONNECTOR

PIN	WIRE	TO	FUNCTION
1	820	J1-12	+5V POWER FOR BASIC REMOTE
2	817	J1-4	REMOTE DISPLAY SYSTEM READY
3	818	J1-5	REMOTE DISPLAY ALARM
4	819	J1-17	REMOTE DISPLAY MAINTENANCE
5	0	GND	NOTE 1

EC CONNECTOR

PIN	WIRE	TO	FUNCTION
1	0	GND	NOTE 1
2	14	J2-8	NOTE 3
3	15A	J2-23	NOTE 5
4	808	J2-2	AIR/FUEL RATIO SOLENOID DRIVER
5	805	J1-35	OXYGEN SENSOR RETURN
6	804	J1-34	OXYGEN SENSOR +

ENGINE CONTROL MODULE CONNECTIONS

J1

PIN	WIRE	TO	FUNCTION
1	178	CUST CON	REMOTE START RETURN
4	817	BWR-2	REMOTE DISPLAY SYSTEM READY
5	818	BWR-3	REMOTE DISPLAY ALARM
6	15	F1	NOTE 4
7	15	F1	NOTE 4
8	0	GND	NOTE 1
9	0	GND	NOTE 1
10	0	MP1-2	FLYWHEEL SENSOR -
11	0A	CAM-3	HALL-EFFECT CAMSHAFT SENSOR -
12	820	BWR-1	+5V POWER FOR BASIC REMOTE
13	SA	MLCB	OUTPUT VOLTAGE SENSING A
14	183	CUST CON	REMOTE START
16	SHLD	MP1-1	FLYWHEEL SENSOR DRAIN
17	819	BWR-4	REMOTE DISPLAY MAINTENANCE
18	767	GOV-2	THROTTLE POSITION FEEDBACK RETURN
19	765	GOV-3	THROTTLE POSITION FEEDBACK SOURCE
20	766	GOV-6	THROTTLE POSITION FEEDBACK SIGNAL
21	68	WTS-2	COOLANT TEMP SIGNAL
22	0	GND	NOTE 1
23	79	MP1-3	FLYWHEEL SENSOR +
24	SB	MLCB	OUTPUT VOLTAGE SENSING B
25	N1	CUST CON	UTILITY VOLTAGE SENSING 1
26	N2	CUST CON	UTILITY VOLTAGE SENSING 2
30	15H	CAM-1	HALL-EFFECT CAMSHAFT SENSOR +
31	573A	WLS-A	COOLANT LEVEL SIGNAL RETURN
32	573	WLS-B	COOLANT LEVEL SIGNAL
33	86	LOS-NC	LOW OIL PRESSURE SIGNAL
34	804	EC-6	OXYGEN SENSOR +
35	805	EC-5	OXYGEN SENSOR RETURN

J2

PIN	WIRE	TO	FUNCTION
1	770	GOV-4	THROTTLE DRIVE HI
2	808	EC-4	AIR/FUEL RATIO SOLENOID DRIVER
3	56B	FS2	STARTING FUEL SOLENOID CONTROL
4	25A	CP-1	IGNITION COIL DRIVE 1 AND 4
5	25B	CP-2	IGNITION COIL DRIVE 2 AND 3
8	14	DB1/FS/EC-2	NOTE 3
9	771	GOV-1	THROTTLE DRIVE LO
10	402	CAM-2	HALL-EFFECT CAMSHAFT SENSOR SIGNAL
11	209	CAR	COMMON ALARM RELAY
12	23	CUST CON	TRANSFER RELAY COIL CONTROL
13	194	CUST CON	TRANSFER RELAY COIL +
14	601	LFP	LOW FUEL PRESSURE
15	210	CAR	COMMON ALARM RELAY
16	6	DPE	EXCITER RETURN
17	162	CB	EXCITER OUTPUT (BREAKER PROTECTED)
18	4	FIELD	FIELD (BRUSH) +
19	1	FIELD	FIELD (BRUSH) -
20	T1	CUST CON	120VAC SOURCE FOR BATTERY CHARGER
21	NEU	CUST CON	120VAC RETURN FOR BATTERY CHARGER
22	56	SC	STARTER CONTACTOR DRIVER
23	15A	EC-3/CP-3	NOTE 5

LEGEND

00 - NEUTRAL	DCVR - DC VOLTAGE REGULATOR	MOV - METAL OXIDE VARISTOR
AFS - AIR/FUEL SOLENOID	DPE - EXCITER	MP1 - MAGNETIC PICKUP
ALT - DC CHARGE ALTERNATOR	EC - EMISSIONS CONNECTOR	OS - OXYGEN SENDER
BAT - BATTERY	F1 - FUSE INLINE	R1 - RESISTOR
BWR - BASIC WIRELESS RECEPTACLE	FS_ - FUEL SOLENOID	SC - STARTER CONTACTOR
CAM - CAMSHAFT SENSOR	GOV - ELECTRONIC GOVERNOR ACTUATOR	SHLD - SHIELD
CAR - COMMON ALARM RELAY	J_ - ENGINE CONTROL MODULE CONNECTOR	SM - STARTER MOTOR
CB - CIRCUIT BREAKER	LFP - LOW FUEL PRESSURE SWITCH	SP_ - SPARK PLUG
CP - COIL PACK	LOS - LOW OIL PRESSURE SWITCH	WLS - COOLANT LEVEL SENDER
DB_ - DIODE BRIDGE	MLCB - MAIN LINE CIRCUIT BREAKER	WTS - COOLANT TEMPERATURE SENDER

LEGEND

AFS - AIR/FUEL SOLENOID	HVR - HIGH VOLTAGE RECEPTACLE 12-PIN
ALT - DC CHARGE ALTERNATOR	J1 - ENGINE CONTROL MODULE 35-PIN CONNECTOR
AS - ALTERNATOR STATOR	J2 - ENGINE CONTROL MODULE 23-PIN CONNECTOR
BA - BRUSH ASSEMBLY	LFP - LOW FUEL PRESSURE SWITCH
BAT - BATTERY	LOS - LOW OIL PRESSURE SWITCH
BWR - BASIC WIRELESS RECEPTACLE	LVP - LOW VOLTAGE PLUG 8-PIN (BULKHEAD)
CAM - CAMSHAFT SENSOR	LVR - LOW VOLTAGE RECEPTACLE 8-PIN
CAR - COMMON ALARM RELAY	MLCB - MAIN LINE CIRCUIT BREAKER
CB - CIRCUIT BREAKER	MOV - METAL OXIDE VARISTOR
CP - COIL PACK	MP1 - MAGNETIC PICKUP
DB - DIODE BRIDGE	NB - NEUTRAL BLOCK
DCVR - DC VOLTAGE REGULATOR	OS - OXYGEN SENDER
EC - EMISSIONS CONNECTOR	R1 - RESISTOR
F1 - FUSE INLINE (25A ATO)	SC - STARTER CONTACTOR
FS - FUEL SOLENOID	SM - STARTER MOTOR
GND - GROUND CONNECTION	TB - TERMINAL BLOCK, CAGE CLAMP
GOV - ELECTRONIC GOVERNOR ACTUATOR	WLS - COOLANT LEVEL SENDER
HVP - HIGH VOLTAGE PLUG 12-PIN (BULKHEAD)	WTS - COOLANT TEMPERATURE SENDER

NOTE: ALL WIRES 18 AWG
300V UL LISTED UNLESS
SHOWN OTHERWISE

AWG SIZE

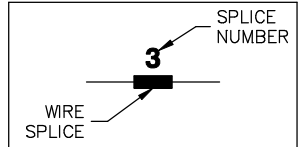

NOTE: ALL WIRES ON THIS
PAGE ARE 600V RATED

COMPONENTS LOCATED IN CUSTOMER CONNECTION BOX

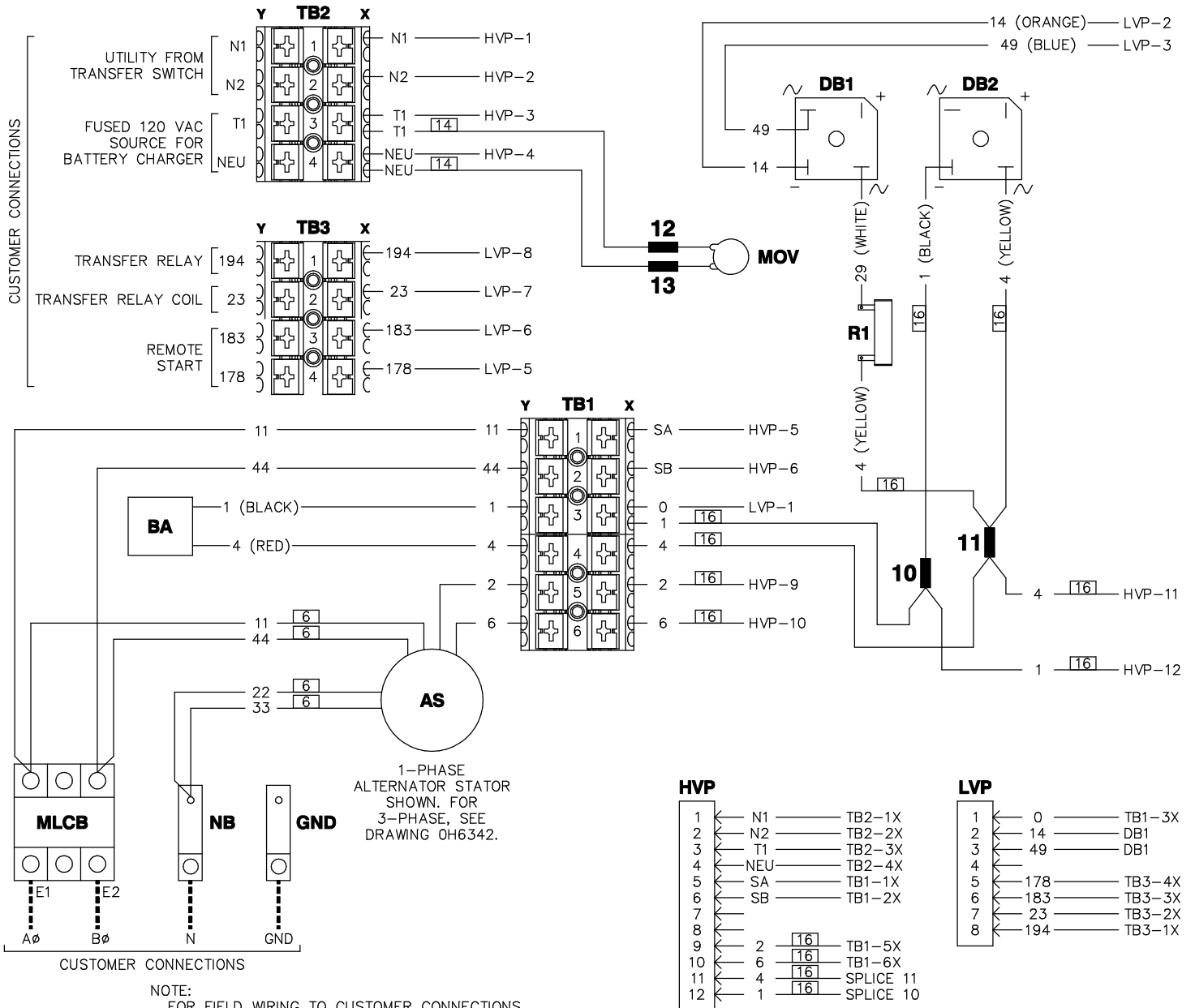

NOTE:
FOR FIELD WIRING TO CUSTOMER CONNECTIONS
(TERMINAL BLOCKS)
MAXIMUM WIRE SIZE: #12 AWG

COMPONENTS LOCATED ON ENGINE

J1

1	178	LVR-5
2		
3		
4	817	BWR-2
5	818	BWR-3
6	15	SPLICE 2
7	15	SPLICE 2
8	0	SPLICE 1
9	0	SPLICE 1
10	0	MP1-2
11	0A	CAM-3
12	820	BWR-1
13	SA	HVR-5
14	183	LVR-6
15		
16	SHLD	MP1-1
17	819	BWR-4
18	767	GOV-2
19	765	GOV-3
20	766	GOV-6
21	68	WTS-2
22	0	SPLICE 1
23	79	MP1-3
24	SB	HVR-6
25	N1	HVR-1
26	N2	HVR-2
27		
28		
29		
30	15H	CAM-1
31	573A	WLS-A
32	573	WLS-B
33	86	LOS-NC
34	804	EC-6
35	805	EC-5

J2

1	770	GOV-4
2	808	EC-4
3	56B	FS2
4	25A	CP-1
5	25B	CP-2
6		
7		
8	14	SPLICE 4
9	771	GOV-1
10	402	CAM-2
11	209	CAR
12	23	LVR-7
13	194	LVR-8
14	601	LFP
15	210	CAR
16	6	HVR-10
17	162	CB
18	4	HVR-11
19	1	HVR-12
20	T1	HVR-3
21	NEU	HVR-4
22	56	SC
23	15A	SPLICE 5

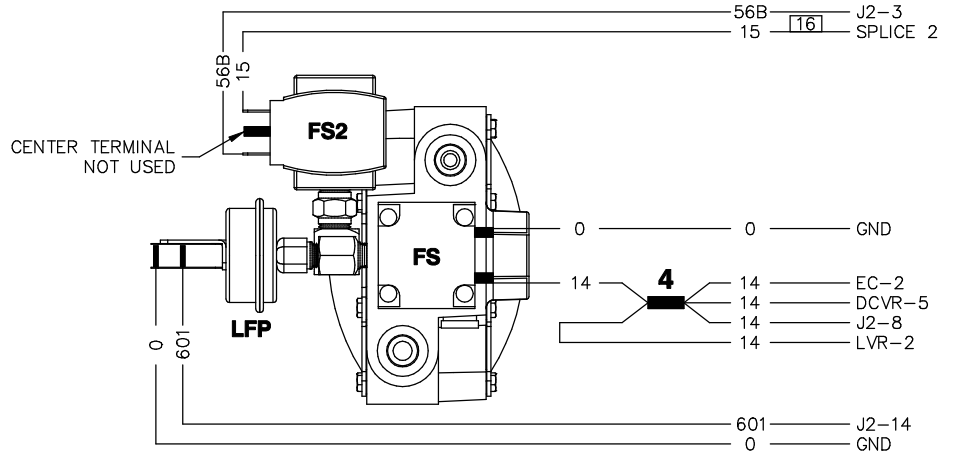

LOCATED BACK OF CUSTOMER CONNECTION BOX

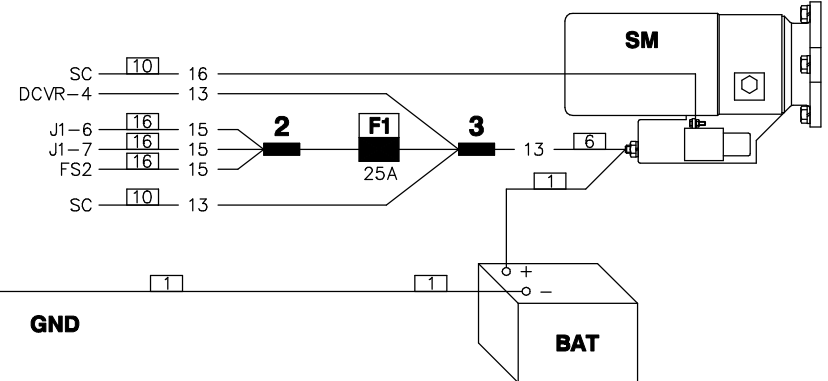
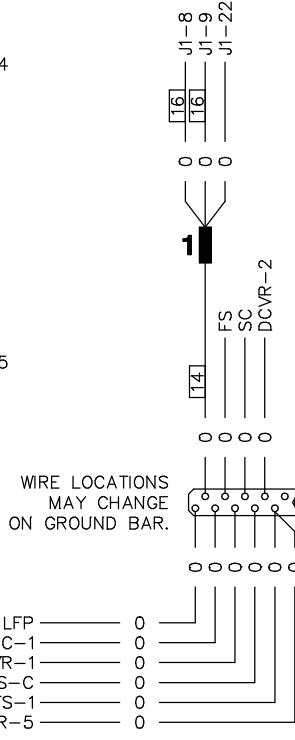
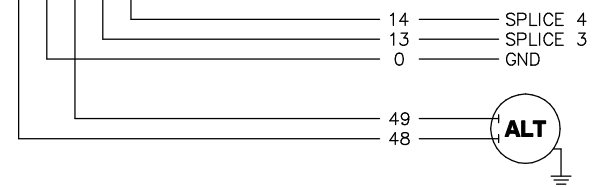
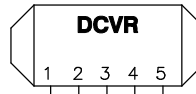
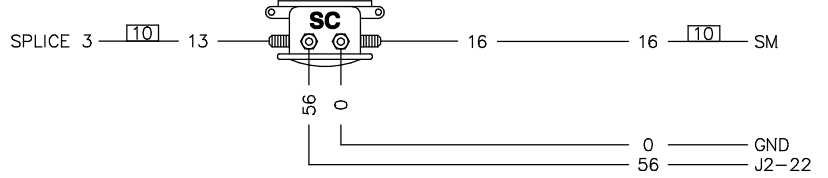

COMPONENTS LOCATED ON ENGINE

HVR

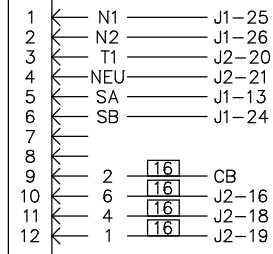

LVR

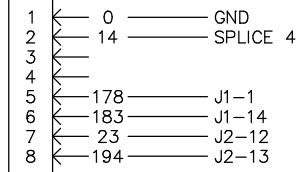

BWR

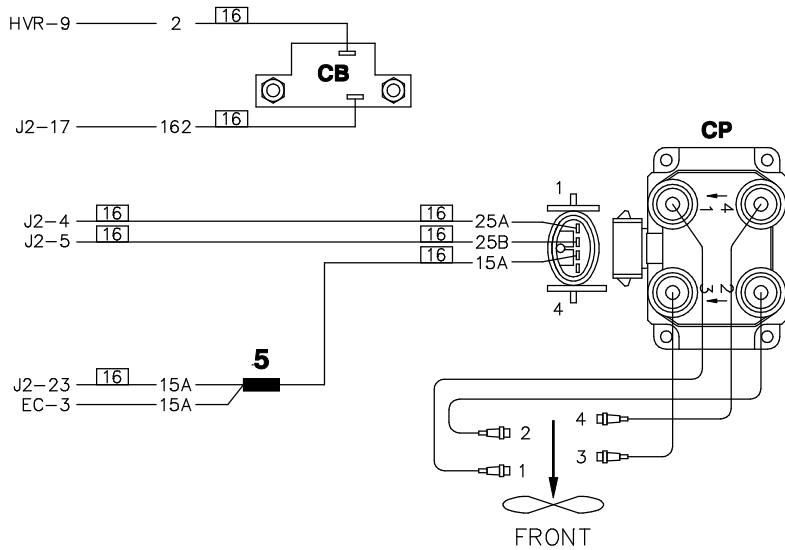
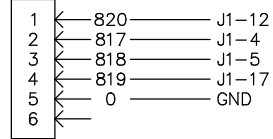

EC

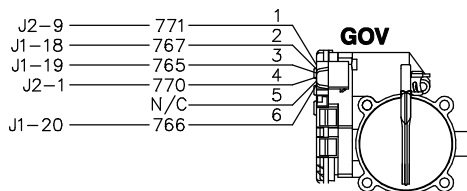
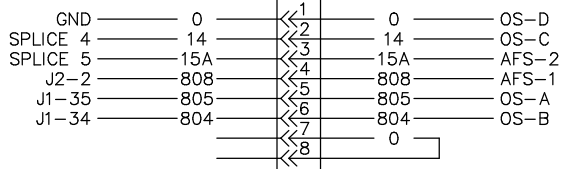

COMPONENTS LOCATED ON ENGINE

